

## Shaft Fan Installation

### Introduction

Shaft driven cooling fans provide a simple and inexpensive way to utilize the full mechanical rating of gear drives by lowering the operating temperatures, thus increasing thermal power capacity. Shaft fans have been successfully used on gear reducers and other related machinery for many years. They eliminate the need for electrically powered cooling devices. The sound level at standard motor rpm is about the same as that from fans on totally enclosed, fan cooled driving motors. Typically, less than 0.25% of a cataloged power rating is required to drive the shaft fans. Dimensions, arrangements, and clearance for shaft driven fans are shown in the selection guide.

The following instructions apply to the installation of the shaft fan kits available for unit sizes 5407J-5608J. Figure 1 shows the general layout of the shaft fan kit installed on the unit. Refer to Figure 2 for the exception to the shaft fan kit for 5507J-5608J installed on the unit (includes an air deflector and an extra set of hex nuts).

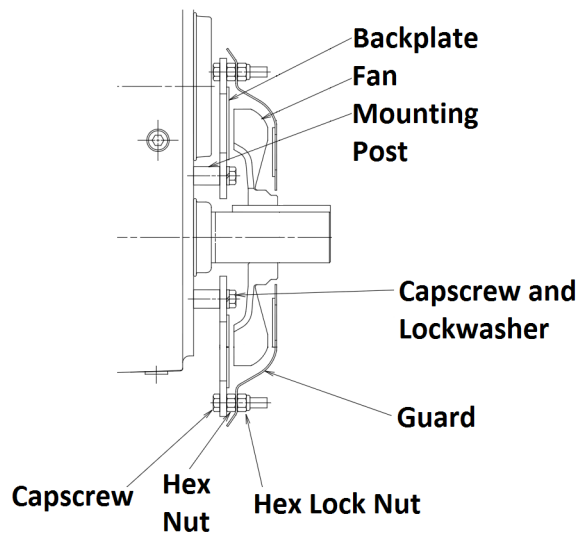

FIGURE 1 SHAFT FAN KIT INSTALLED ON UNIT

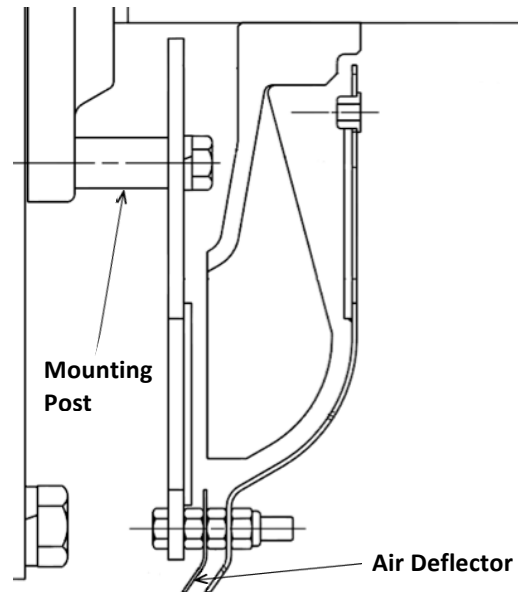

FIGURE 2 AIR DEFLECTOR AND ADDITIONAL HEX NUT (5507J AND 5608J)

### Assembly Instructions

**WARNING:** Consult applicable local and national safety codes for proper guarding of rotating members.

Switch off the main power supply and lockout, de-energize, remove all external loads from drive before servicing drive or accessories.

1. Begin by arranging capscrews and lock washers through the backplate and mounting posts. Refer to Figure 1 for a depiction of the finished assembly. The mounting posts that are supplied with the shaft fan assembly maybe of different lengths. This is to keep the shaft fan extended parallel with the reducer housing wall. For example the mounting post that is shown in Figure 1 is mounted directly to the housing wall. Where as the mounting post location shown in Figure 2 is mounted to the seal cage. Torque the 0.375"-16 UNC capscrews to 25-30 lb-ft (or 61-74 lb-ft for 0.500"-13 UNC capscrews used on the 5608J).

2. Assemble shaft fan to fan hub, apply Loctite 242 or equivalent to fastener threads and tighten.  
**CAUTION:** Do not over-tighten fasteners into plastic fan as fan may crack.
3. Mount the fan hub on the gear drive high speed shaft such that the set screw hole in the hub is towards the end of the shaft. Locate the hub axially at the values listed in Table 1 and Figure 4, between the backing plate and the fan.
4. Once the fan is correctly positioned, use Loctite 222 on the set screw.
5. Torque the 0.250"-20 UNC set screw to 6.5-8 lb-ft.
6. Install the capscrews and hex nuts in the outer bolt circle of the backplate. The 0.375"-16 UNC hex nuts can be tightened to a torque of 25-30 lb-ft at this time.  
**NOTE:** If applicable on 5507J and 5608J; install the air deflector and additional set of hex nuts at this time, as depicted in Figure 2. The 0.375"-16 UNC hex nuts can be tightened to a torque of 25-30 lb-ft at this time.
7. Place the guard over the capscrews, and tighten the 0.375"-16 UNC nylon collar lock nuts to 28-35 lb-ft.

**TABLE 1 GAP DISTANCE FOR FAN PLACEMENT ON SHAFT**

| Unit Size | Gap (X) (Inch) |
|-----------|----------------|
| 5407      | 0.25           |
| 5415      | 0.25           |
| 5507      | 0.31           |
| 5608      | 0.38           |

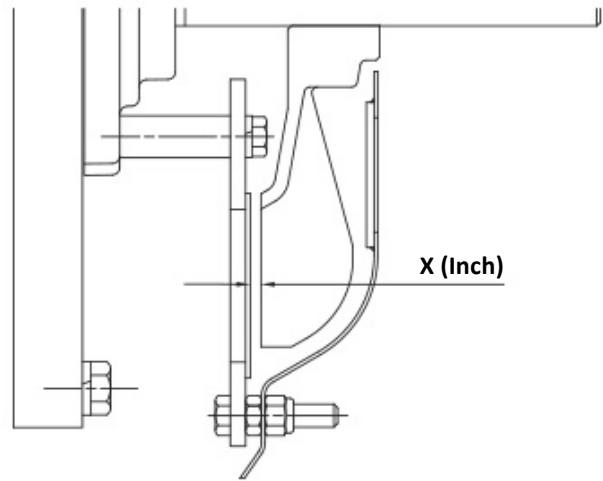

**FIGURE 4 FAN GAP MEASURED FROM INSTALLED BACKING PLATE**

**NOTE:** When a V-Belt guard is used with the shaft fan, the lock nut must be reused in the inside of the V-Belt guard enclosure. See the section entitled "OSHA V-Belt Guard Installation For Drives With Shaft Fan" of publication 378-912.

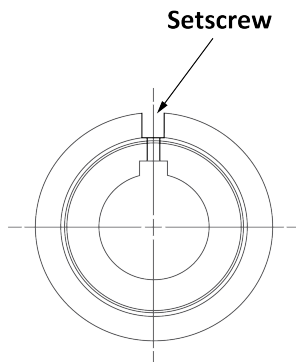

**FIGURE 3 FAN HUB ASSEMBLY**