

300 Series PA Pump and Cooler Assemblies

Pump and Cooler Assemblies with Air/Oil Heat Exchanger

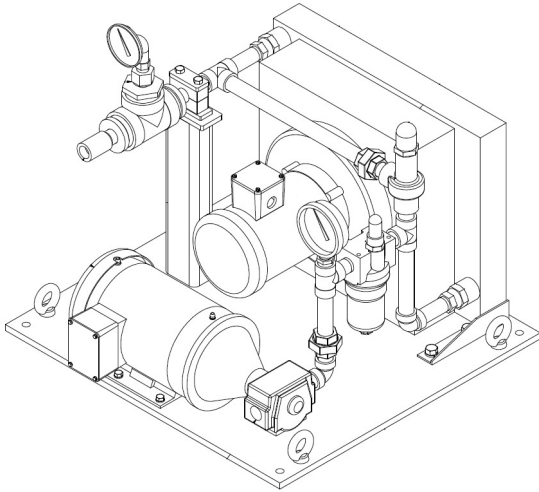

When compact gear drives require assistance to dissipate thermal energy, Rexnord® offers the following cooling accessories:

- Shaft Driven Cooling Fans
- Electric Cooling Fans
- Falk V-Class™ DuraPlate Cooling Package (Air/Oil)
- Cooling Tubes
- Type PC Pump and Cooler Assembly (Water/Oil)
- Type PA Pump and Cooler Assembly (Air/Oil)

Rexnord recommends the most economical cooling accessory that meets the demands of the application and any associated customer specifications. Pump and cooler assemblies are commonly suggested when the thermal requirements exceed that which can be accommodated by shaft driven fans, electric cooling fan, or cooling tubes.

300 Series PA Pump and Cooler Assemblies with Air/Oil Heat Exchanger are typically preferred when water is unavailable, or where water is subject to freezing.

Note: Pump and cooler assemblies described in this guide are offered as oil-cooling devices for use on gear drives for both splash lubrication and pressure/jet lubrication. Splash assures adequate oil flow to bearings and gearing regardless of whether the pump and cooler assembly is activated. Pressure lubrication is Falk® jet lube, pressure feed to bearings or other dependencies associated with continuous flow of lubrication supplied by the lube pump. With pressure lubrication the pump and motor must always be in operation when the gear drive is operating.

This Owner's Manual covers 300 Series PA Pump and Cooler Assemblies with Air/Oil Heat Exchanger. Ten (10) sizes are available. See Table 1, on page 3, which provides the oil flow rate and heat dissipation capacity of each size of the 300 Series PA Pump and Cooler Assemblies, as well as a general description of the individual components that make up each size. Rexnord reserves the right to substitute equivalent brands of components.

Each 300 Series PA Pump and Cooler Assembly includes oil lube pump and motor assembly (pump, motor, flange and coupling), air/oil heat exchanger (cooler, fan, motor and shroud), oil filter and heat exchanger pressure bypass valve. All components are pre-assembled with piping and socket welded fittings on a common steel mounting plate, which can be fastened to a suitable foundation.

300 Series PA Assemblies are furnished to be floor mounted. Rexnord furnishes only oil piping from the lube pump to the heat exchanger inlet. Refer to Table 2 on page 4 for recommended minimum lube line sizes of the customer furnished oil suction and oil discharge lines, based on line length.

When requested, and where determined feasible by Rexnord, 300 Series PA Assemblies may be mounted directly to the gear drive at an additional charge.

When Rexnord mounts the 300 Series PA Assemblies on the gear drive, all oil line connections are supplied and completed. A thermometer and pressure gauge are included as standard components on 300 Series PA Assemblies.

Special Cooler Accessories

Contact Rexnord for other non-standard component accessories, such as a temperature switch to cycle heat exchanger fan motor and warning device, oil flow indicator/switch, oil heater, oil sump tank, etc.

Oil Flow Indicator/Switch

Gear drives equipped with a pump and motor for the lubrication of bearings or gear meshes (pressure lubrication) require the pump be operating before the gear drive is operating. To insure the pump is operating, an oil flow indicator/switch can be added as a non-standard accessory. Connecting this switch with the main motor controls can insure oil flow to the gear drive before the main motor is started. Typical oil flow indicators/switches have NEMA 4 enclosures. Other types of enclosures are available at an additional charge.

Temperature Switch

When gear drives equipped with 300 Series PA Assemblies are started after extended idle periods, lubricant in the gear drive sump will not be at operating temperature, and may be at viscosities exceeding 2160 cSt (10,000 SSU). Startups with lubricant at elevated viscosity levels may result in pump cavitations, pump motor overload, and damage to components. Where cold start conditions are anticipated specify a non-standard temperature switch (additional charge) when ordering the pump and cooler assembly. A temperature switch can be connected to start the pump motor at acceptable viscosities in the gear drive, and to cycle (start/stop) the cooler fan motor when oil cooling is or is not required. Typical temperature switches have NEMA 4 enclosures. Other types of enclosures are available at an additional charge.

Temperature Sensors (RTD and Thermocouple)

When the cooling system temperature is to be monitored and/or computer controlled, a non-standard resistance temperature detector (RTD) or non-standard thermocouple sensor can be provided. Typical RTDs provided are platinum (100 Ω) with a temperature coefficient of resistance (α) of 0.00385 $^{\circ}\text{C}^{-1}$. Typical thermocouples are insulated Type E MgO. Sensors will be provided with NEMA 4 screw cover connections heads. Others are available at an additional charge. **Note:** Sensors are available to be mounted in the gear drive sump and must be specified when ordering the gear drive.

Oil Immersion Heater

Lubricant viscosity recommendations shown in Falk gear drive service manuals for enclosed gear drives are applicable to these PA assemblies. However, for operation at ambient temperatures where the oil viscosity exceeds 2160 cSt (10,000 SSU) ($\approx 50^{\circ}\text{F}/10^{\circ}\text{C}$), a gear drive equipped with 300 Series PA Assembly should also be equipped with a gear drive oil sump immersion heater (available at an additional charge).

Oil Pressure Switch

An oil pressure switch is not a recommended safety device for 300 Series PA Assemblies. Gear oils have a wide range of viscosity conditions depending on the temperature and grade of the oil. The change in viscosity (temperature of oil) has a direct affect to the operating pressure of the cooling system. A set point cannot be determined and is therefore not recommended.



Table 1 – Typical Specifications for 300 Series PA Pump and Cooler Assemblies (Air/Oil)*

Pump & Cooler Assembly		300PA	305PA	310PA	320PA	330PA	340PA	350PA	350B-PA	360PA	370PA											
Lube Pump		HAIGHT PUMPS, DIV OF BAKER MFG.																				
Coupling		LOVEJOY JAW TYPE																				
Heat Exchanger		ITT Standard, AirEX Aluminum																				
Relief Valve		FULFLO SPECIALTIES, INC., VJ SERIES																				
Filter - 20 µm	Housing	PARKER FILTER, CN SERIES																				
	Element	936705Q	936705Q	936705Q	936712Q	936712Q	936719Q	936719Q	936719Q	936719Q	936719Q											
Pressure gauge		ASHCROFT, 3.5" 1009 DUAL SCALE																				
Thermometer		ASHCROFT, 3" EI DUAL SCALE																				
Lube Pump and Heat Exchanger Motor Options		60 Hz AC Electric Motor 3 Phase, TEFC 208-230 / 460 Volts																				
		60 Hz AC Electric Motor 3 Phase, TEFC 575 Volt																				
		50 Hz AC Electric Motor 3 Phase, TEFC 220 / 380 / 440 Volts																				
Typical	Pump * HP (kW)	1	(0.75)	1.5	(1.1)	2	(1.5)	5	(3.7)	7.5	(5.6)	7.5	(5.6)	10	(7.5)	10	(7.5)	15	(11.2)	15	(11.2)	
Motor Power	Fan HP (kW)	0.5	(0.37)	0.5	(0.37)	0.5	(0.37)	0.5	(0.37)	0.75	(0.56)	1.5	(1.1)	2	(1.5)	5	(3.7)	5	(3.7)	5	(3.7)	
Pump Oil Flow Rate (60/50 Hz) GPM		60	50	60	50	60	50	60	50	60	50	60	50	60	50	60	50	60	50	60	50	
		1.6	1.3	3	2.5	4.5	3.6	11.6	9.5	20	16.4	29	24	40	32	40	32	43	36	52	42	
		L/m	6	4.9	11.4	9.5	17	13.6	44	36	76	62	110	91	151	121	151	121	163	136	197	159
Max Dissipation BTU/Hr (x1000) †		18.9	16.0	34.1	28.5	55.0	46.4	84.0	71.7	151.5	130.1	230.7	197.2	311.0	260.4	395.0	334.0	407.0	350.0	553.0	467.0	

*Rexnord reserves the right to substitute equivalent brands or components.

† Dissipation rates (BTU) are based on seal level elevation and ambient temperature of 80°F (27°C). Contact Rexnord if your application will require corrections for altitude or ambient temperatures.

Table 2 – 300 Series PA Pump and Cooler Assemblies – Minimum Lube Line Sizes

	Lube Line Length		Minimum Lube Line Inside Diameter [^]																					
			Air/Oil Cooler Size																					
			300PA		305PA		310PA		320PA		330PA		340PA		350PA		350B-PA		360PA		370PA			
Ft	m	inch	mm	inch	mm	inch	mm	inch	mm	inch	mm	inch	mm	inch	mm	inch	mm	inch	mm	inch	mm			
Oil Suction Line (Pump Inlet)	3	0.91	1.00	25	1.00	25	1.00	25	1.25	32	1.75	45	2.00	51	2.50	64	2.50	64	2.50	64	2.75	70		
	5	1.52	1.00	25	1.00	25	1.25	32	1.50	38	1.75	45	2.00	51	2.50	64	2.50	64	2.50	64	2.75	70		
	10	3.05	1.25	32	1.25	32	1.50	38	1.75	45	2.00	51	2.25	57	2.50	64	2.50	64	2.50	64	2.75	70		
	15	4.57	1.25	32	1.50	38	1.50	38	2.00	51	2.25	57	2.50	64	2.75	70	2.75	70	2.75	70	3.00	76		
	20	6.10	1.25	32	1.50	38	1.75	45	2.00	51	2.25	57	2.75	70	3.00	76	3.00	76	3.00	76	3.00	76		
	25	7.62	1.50	38	1.50	38	1.75	45	2.25	57	2.50	64	2.75	70	3.00	76	3.00	76	3.00	76	3.25	83		
	30	9.14	1.50	38	1.75	45	1.75	45	2.25	57	2.75	70	3.00	76	3.25	83	3.25	83	3.25	83	3.50	89		
Oil Discharge Line (Exchanger Outlet)	3	0.91	0.75	19	0.75	19	0.75	19	1.00	25	1.25	32	1.25	32	1.50	38	1.50	38	1.50	38	1.50	38		
	5	1.52	0.75	19	0.75	19	1.00	25	1.25	32	1.25	32	1.50	38	1.75	45	1.75	45	1.75	45	1.75	45		
	10	3.05	1.00	25	1.00	25	1.00	25	1.25	32	1.50	38	1.75	45	2.00	51	2.00	51	2.00	51	2.00	51		
	15	4.57	1.00	25	1.00	25	1.25	32	1.50	38	1.75	45	2.00	51	2.00	51	2.00	51	2.00	51	2.25	57		
	20	6.10	1.00	25	1.25	32	1.25	32	1.50	38	1.75	45	2.00	51	2.25	57	2.25	57	2.25	57	2.25	57		
	25	7.62	1.00	25	1.25	32	1.25	35	1.75	45	2.00	51	2.00	51	2.25	57	2.25	57	2.25	57	2.50	64		
	30	9.14	1.25	32	1.25	32	1.50	38	1.75	45	2.00	51	2.25	57	2.50	64	2.50	64	2.50	64	2.50	64		

[^]Applies to AGMA #4, #5, and #6 lubricants at a minimum temperature of 50°F assuming the pump inlet is located below the gear reducer outlet.

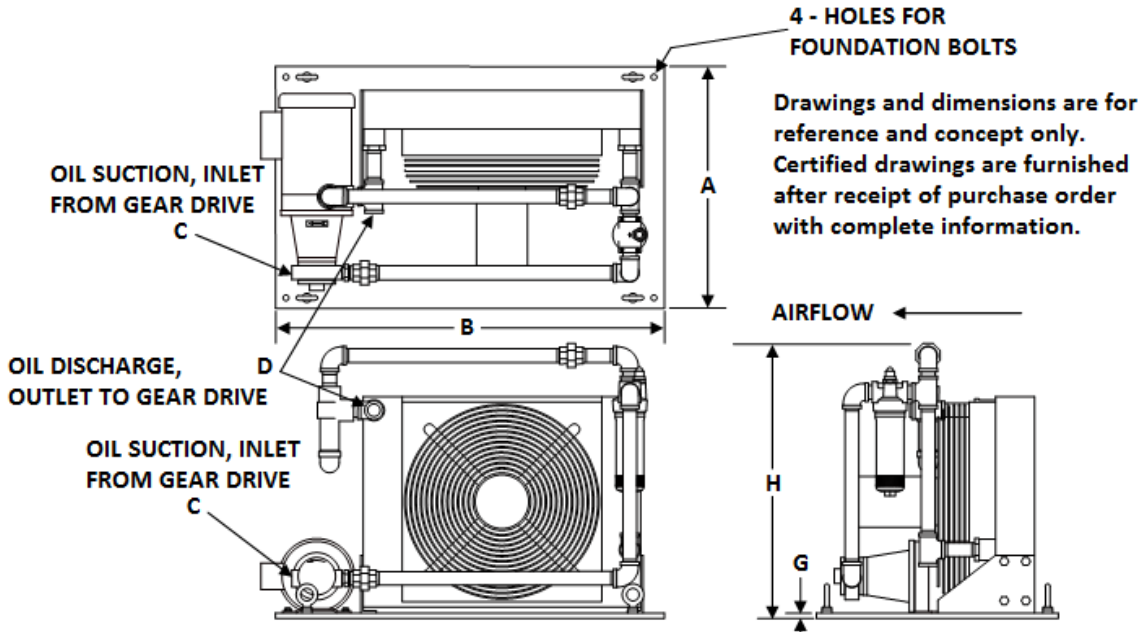

Cooler Size	A		B		C	D	G		H		Weight/Mass	
	inch	mm	inch	mm	NPT	NPT	inch	mm	inch	mm	lbs	kg
300PA	25.0	635.0	26.38	670.1	0.75	0.75	0.5	12.7	24.58	624.3	300	136
305PA	25.0	635.0	26.38	670.1	0.75	0.75	0.5	12.7	24.58	624.3	350	159
310PA	23.0	584.2	37.00	939.8	0.75	1.00	0.5	12.7	28.79	731.3	415	188
320PA	26.5	673.1	42.00	1066.8	1.00	1.25	0.5	12.7	28.79	731.3	570	259
330PA	29.8	755.7	53.00	1346.2	1.25	2.00	0.5	12.7	30.27	768.9	900	408
340PA	36.0	914.4	57.39	1457.7	1.50	2.00	0.5	12.7	40.69	1033.5	1250	567
350PA	36.0	914.4	58.37	1482.6	1.50	2.00	0.5	12.7	43.52	1105.4	1300	590
350B-PA	36.0	914.4	66.00	1676.4	1.50	2.00	0.5	12.7	45.72	1161.3	1550	703
360PA	50.0	1270.0	58.00	1473.2	2.00	2.00	0.5	12.7	45.72	1161.3	1600	726
370PA	49.0	1244.6	62.00	1574.8	2.00	2.00	0.5	12.7	58.64	1489.5	1900	862

Components

Heat Exchanger (ITT Standard AirEx)

Maximum operating pressure: 250 psi. (kPa)
 Maximum operating temperature: 250°F (121°C)
 Aluminum cooler, steel shroud

Cooler Motor^^

Standard motors minimum ratings. NEMA Frame,
 Design B, Insulation Class F, UL, CSA, CE

Pump

Maximum operating pressure: 150 psi. (1035 kPa)
 Maximum peak pressure: ≈225 psi. (1550 kPa)
 Ductile Iron housing, Buna-N Seal

^^Motors supplied for the 300 Series PA assemblies are generic in nature. The manufacture is not specified so as to allow the supplier to select a motor manufacture to meet the requirements of the order, price and delivery. An order for multiple coolers could have several different motor manufactures for the same size motor. For example, if six (6) 310PA assemblies are ordered, requiring a 2 HP motor for the pump and motor assembly, the motors selected will be the same frame size, speed, electrical requirement and HP. The manufacture could be (but not limited to) 2 each Leeson, 2 each Baldor and 2 each Siemens. If all of the same motor manufactures are required, there will be an extra charge to specify a unique manufacture.

Pump Motor^^

Standard motors minimum ratings. NEMA Frame,
 Design B, Insulation Class F, UL, CSA, CE

Filter (Parker CN Series)

Maximum operating pressure: 550 psi. (3790 kPa)
 Maximum operating Temperature: 225°F (107°C)

Aluminum Head and Bowl

Bypass Valve, Cooler (Fulflo VJ series)

Maximum operating pressure: 1500 psi. (10340 kPa)
 Operating temperatures: 20 to 400°F (-7 to 204°C)

Cast iron body

Installation Instructions

Caution – Lock out power sources and remove all external loads from the gear drive before servicing the gear drive or accessories. Ensure adequate electrical service is available to operate pump motor and cooler motor.

Notice: When ordering parts, or requesting information, provide the Falk M.O. Number, gear drive size, high-speed shaft rpm, ratio, and date that are stamped on the gear drive nameplate. Any Falk drawing numbers available should be supplied also.

Always locate floor-mounted pump and cooler assemblies in close proximity to the gear drive to minimize pressure drop in the oil lines. Special attention should be given to the suction lines. Avoid tees, elbows, valves and other flow restriction devices as much as possible. Excess flow restriction devices may require an increase in the minimum recommended line size. Minimum lube line sizes are indicated in Table 2 on page 4. It is recommended that oil lube pumps be mounted below the gear drive oil level to minimize suction head and maintain a prime.

Should an isolation valve be used, it is recommended the valve be installed at the gear drive suction port. The valve should be a full port valve to minimize pressure drop.

Provide adequate support for the pipe connection to the pump. Do not use the pump for pipe support.

Refer to 300 Series PA certified print and gear drive certified print for final dimensions, designation of components, and exact location and description of inlet/outlet hook up points.

The atmosphere in the immediate area of the 300 Series PA Assembly must be free of lint, dirt, etc. to maintain efficient operation of the assembly.

Note: Never operate the lube pump dry. Fill the pump lines with oil before starting pump. Running the pump dry can cause bearing failure and pump seal failure.

CAUTION

When making any and all electrical connections, consult with and follow all local and national electrical codes.

After the electrical connections have been made, verify the correct rotation of the lube pump motor and the cooling fan motor. Refer to drawings and rotation arrows on the components for the correct rotation. Correct rotation of the lube pump motor will result in a good flow of oil in the gear drive lube system. Run the pump motor long enough to purge any air that might be in the lube system and lines.

After the air is purged and there is a good flow of oil, shut off lube the pump motor and let sit for approximately five minutes. Re-check the oil level in the gear drive. Add additional oil as needed. Some oil will have filled the cooler and the lube lines. This oil will need to be replaced after initial startup.

It is recommended that the fan motor be controlled with an oil sump temperature-monitoring device. Fan motor control can be accomplished with a non-standard temperature switch, RTD or thermocouple. These devices can be used to cycle the fan motor when cooling of the oil is required, or to maintain a lower temperature to extend oil life.

Operation

Never exceed the maximum allowable temperature and/or pressure ratings of any of the components.

Any instructions or directions that are provided on the certified drawings supersede this bulletin.

There are three recommended methods for operating the 300 Series PA Assembly. Each method will require a non-standard temperature-sensing device. The methods described are for a 300 Series PA Assembly that is used for cooling only, or a 300 Series PA Assembly that is used for forced lubrication (jet lube) and cooling. All options are to have an AGMA recommended maximum continuous gear drive oil sump temperature of 200°F (93°C). A gear drive shutdown temperature of approximately 210°F (99°C) can be used. **Note:** Synthetic oils are designed to operate at higher temperatures than conventional gear oils. Consult with the oil manufacture for the recommended maximum operating temperature of the oil that is being used.

Monitor operation and temperatures when the system is operating at normal running conditions. Log the temperatures and monitor through time. Any sudden increase in temperature in the gear drive sump oil can be an indication of a problem with the lubrication system or gear drive. Check for a dirty

cooler, proper operation of the cooling fan and pump operation.

The filter assembly has a differential pressure indicator and bypass valve. Bypass may be indicated due to a dirty filter during cold startup at elevated viscosity levels. Monitor the differential pressure indicator after the gear drive reaches normal operating temperatures.

Option 1, Cooling Only (see Figure 1 for proposed wiring with temperature switch, page 8)

Gear drives that have a 300 Series PA Assembly for cooling only will have an internal splash lubrication system. Oil is circulated through the PA assembly to remove heat from the oil and provide oil filtration. For these drives, start the lube pump when the gear drive main motor is started. Use a temperature switch or other temperature-sensing device to cycle the fan motor. Set the fan motor temperature sensing device to cycle when the lubricant in the gear drive sump reaches 140°F to 160°F (60°C to 71°C).

Option 2, Cooling Only (see Figure 2 for proposed wiring with temperature switch, page 9)

Gear drives that have a 300 Series PA Assembly for cooling only will have an internal splash lubrication system. Oil is circulated through the PA assembly to remove heat from the oil and provide oil filtration. Some applications have low ambient temperature conditions at the 300 Series PA Assembly. These temperatures could be as low as 50°F (10°C) but not less than 20°F (-7°C). For these installations, start the lube pump when the gear drive sump oil reaches approximately 120°F (50°C). Start fan motor when lube oil in gear drive sump reaches 140°F to 160°F (60°C to 71°C).

Option 3, Force Lubrication and Cooling (see Figure 1 for proposed wiring with temperature switch, page 8)

Some gear drives require force lubrication to the bearings and/or to the gear mesh(s). Drives may require forced lubrication due to variable input speeds, excessive high speed shaft speeds, high bearing rib velocities and/or high gear mesh pitch line velocities. Forced lubrication gear drives will have external and/or internal lubrication lines feeding oil to components requiring forced lubrication. Gear drive lubrication lines are

connected to the oil return from the 300 Series PA Assembly.

It is recommended that the lubrication pump in the 300 Series PA Assemblies used for gear drives requiring forced lubrication be operating before the gear drive is put into operation. As a rule, the lube pump should be operating for at least two minutes before the gear drive is started. The time the lube pump is in operation before the gear drive is started can be adjusted. The minimum operating time should be sufficient enough to provide consistent oil flow from the 300 Series PA Assembly, and all air has been purged from the 300 Series PA Assembly.

After proper flow of lubricant is verified, the gear drive can be put in to operation. The non-standard temperature sensing device is to be set for cycling the cooling fan at 140°F to 160°F (60°C to 71°C).

Maintenance Instructions

Caution – Lock out power source and remove all external loads from the gear drive before servicing the gear drive or accessories.

Maintenance of the heat exchanger includes cleaning of the inside and outside of the cooler. External cleaning of the heat exchanger can be done by washing the cooler with a mild cleaner compatible with aluminum or with compressed air. For heavier contaminants a power spray washer will also work. Care is to be taken not to damage the fins of the cooler.

For internal cleaning of the cooler use a cleaner solution that is suitable to remove the deposits left from the gear oils. This cleaner is to be compatible with aluminum and should be circulated through the cooler until clean. After cleaning, dry with compressed air or flush with clean oil.

Maintenance of the oil filter consists of replacing the filter element. Refer to the manufacturer's bulletin available on the manufacturer's web site for further maintenance procedures.

For detailed maintenance instructions and specifications on other components such as lube pump, relief valve, etc., refer to the product manufacturer's literature available on manufactures web sites.

Figure 1 – Proposed Temperature Switch Wiring

Splash or Pressure Lubrication – 300 Series PA assembly pump motor will always be operating when gear drive is operating.

Fan motor will only operate when required (see Option 1 or Option 3).

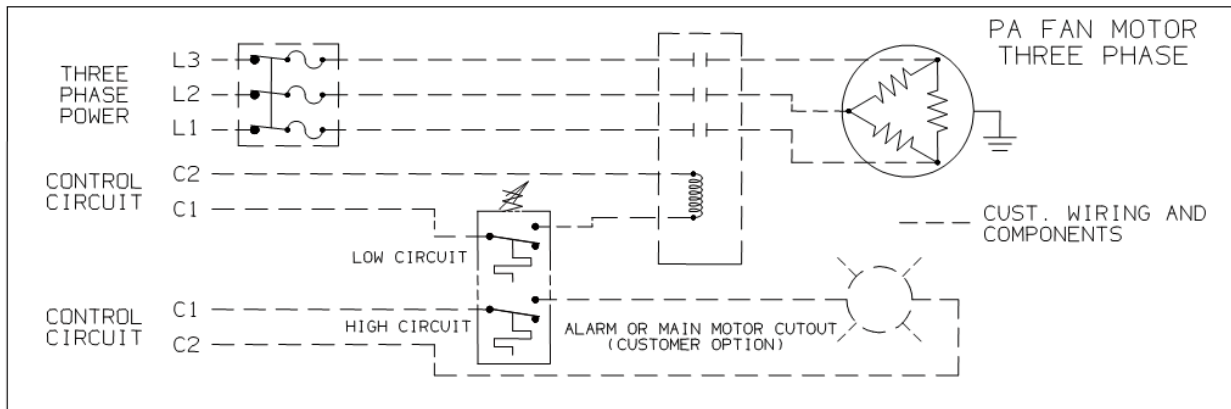
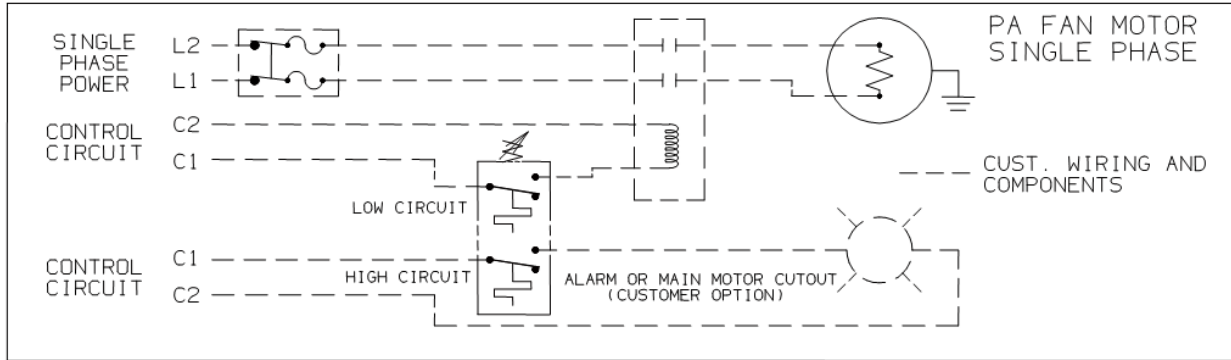

Figure 2 – Proposed Temperature Switch Wiring

Splash Lubricated – 300 Series PA assembly will be used for cooling only (not for pressurized lubrication).
 Pump motor and fan motor will only operate when required (see Option 2).

