



QUICK SHIP PROGRAM

# GET YOUR COOLING TOWER GEAR DRIVE FASTER THROUGH NORTH AMERICA QUICK SHIP PROGRAM

Regal Rexnord offers its exclusive Quick Ship capability on **Falk® 2255, 2275, 2310, and 2350 CTA Gear Drives** to provide solutions faster than industry-standard lead times.

With dedicated resources and stocked parts at our Lincoln, NE, plant, Regal Rexnord can deliver orders in **2-4 weeks** for quantities 3 or less of inventoried ratios! As a resource for both new installations and replacement parts, customers can count on Regal Rexnord.



### FALK CTA GEAR DRIVES:

- Directly replaces Amarillo®\* 1110, 1311, 1712, and 1713A Gearboxes
- Meets the requirements of CTI STD-111 and AGMA standards
- All bearings are rated for 100,000+ hour L10 life
- USA assembly capability for Quick Ship program

### AVAILABLE OPTIONS:

- Low oil level switch
- Immersion oil heater
- Vibration sensors
- RTD temperature sensors
- Anti-reverse backstop

### INVENTORY IN LINCOLN, NE

Gearbox Size	Available Ratios
2255	7.5, 8, 8.5, 9, 9.5, 10, 10.5, 11, 12, 13, 14
2275	8, 8.5, 9, 9.5, 10, 10.5, 11, 12, 13, 14, 15, 17
2310	9, 10, 10.5, 11, 12, 12.5, 13, 14, 15, 16
2350	11, 12, 13, 14, 15, 15.5, 16, 17, 18, 20

Other ratios are available outside of the Quick Ship program.

## 2-4 week lead time on CTA units!

\* Amarillo is believed to be the trademark and/or trade name of Amarillo Gear Company LLC and is not owned or controlled by Regal Rexnord Corporation or its affiliates.



# FALK® CT SERIES QUICK SHIP PROGRAM

FOR OVER 100 YEARS, Falk has been trusted to design and manufacture gear drives for the world's most demanding applications. Our engineers created the **CT Series Cooling Tower Gear Drive** to address common issues in the cooling tower industry. The Falk CT Series helps reduce operating costs and increases uptime, resulting in more efficient operations in the harsh rigors of cooling tower and vertical drive applications.

## DIRECT DROP-IN REPLACEMENT FOR AMARILLO®\* GEARBOXES

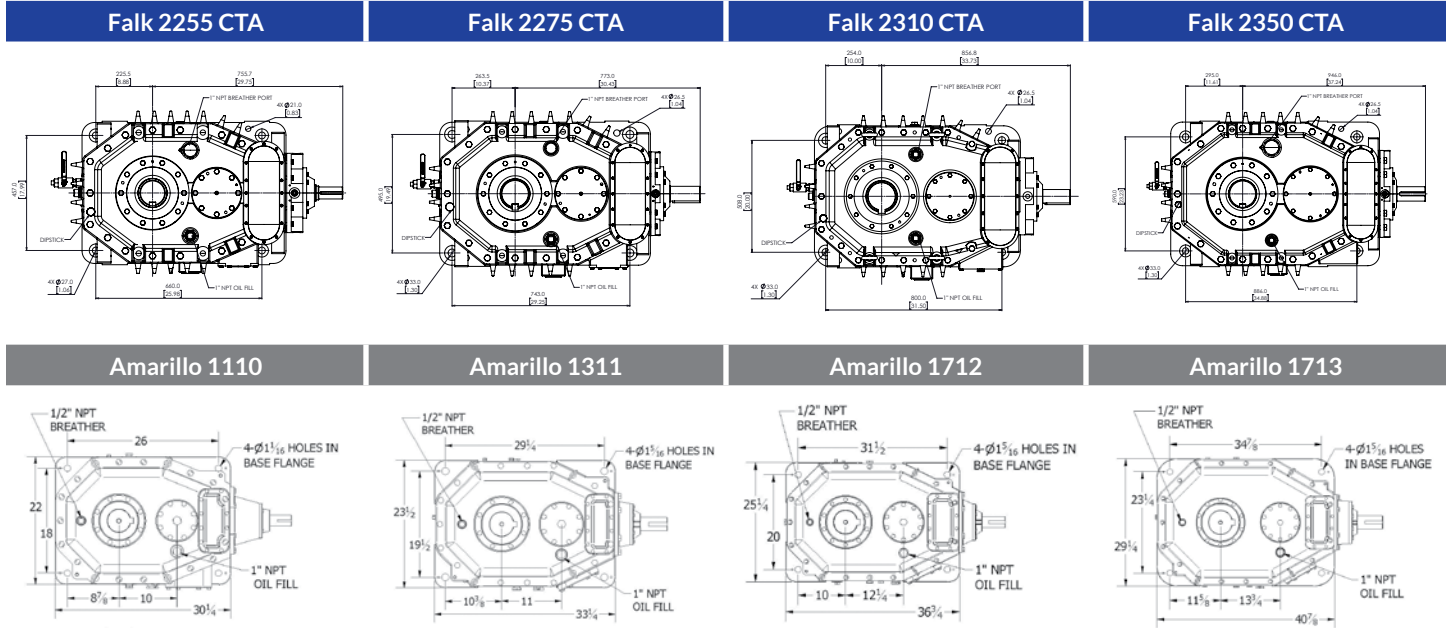

\*Amarillo is believed to be the trademark and/or trade name of Amarillo Gear Company LLC and is not owned or controlled by Regal Rexnord™ Corporation or its affiliates.

## FALK CTA COOLING TOWER GEAR DRIVE FEATURES AND BENEFITS:

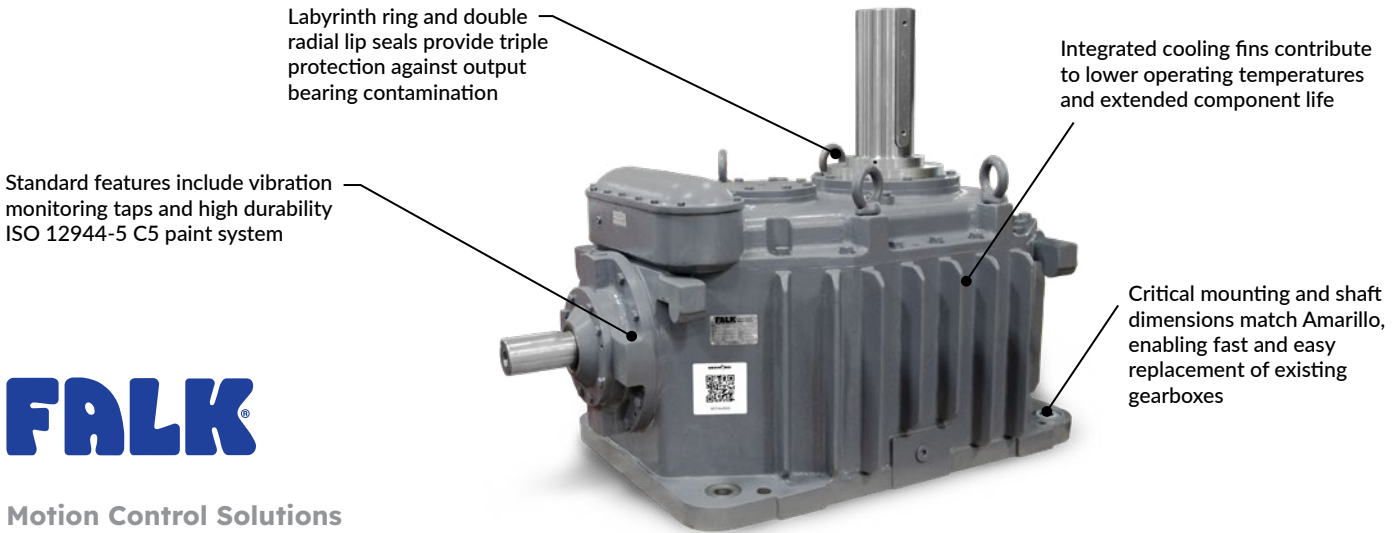

Motion Control Solutions  
Regal Rexnord

Contact us: [rexnord.com/contact](http://rexnord.com/contact)  
[regalrexnord.com](http://regalrexnord.com)

The proper selection and application of products and components, including assuring that the product is safe for its intended use, are the responsibility of the customer. To view our Application Considerations, please visit <https://www.regalrexnord.com/Application-Considerations>. To view our Standard Terms and Conditions of Sale, please visit <https://www.regalrexnord.com/Terms-and-Conditions-of-Sale> (which may redirect to other website locations based on product family).

### REQUEST A QUOTE:

Chris Cowins, Cooling Tower Business  
Development Manager  
[Chris.Cowins@RegalRexnord.com](mailto:Chris.Cowins@RegalRexnord.com)  
Adam Stultz, Strategic Account Manager  
[Adam.Stultz@RegalRexnord.com](mailto:Adam.Stultz@RegalRexnord.com)

