

Design Features include:

- Unitized disc packs allowing easy installation
- High torque to outer diameter ratio resulting in smaller coupling selection and higher speed potential

Applications:

- Pumps
- Compressors
- Fans

Industry Compliant:

- ISO 14691
- ATEX II 2GD c T5

Special design options:

- Electrically insulated
- Torsionally adjusted
- Limited end float
- Torque meter
- Reduced sparking

Rexnord Thomas SR52 Disc Coupling

Customer-focused solutions.
Reliable Performance.
Trusted Brands.

You want a trusted name when it comes to providing engineered power transmission products that improve productivity and efficiency. Rexnord® provides superior products for your industrial applications world wide. We work closely with you to reduce maintenance costs, eliminate redundant inventories and prevent equipment downtime.

Thomas SR52

The Rexnord Thomas SR52 is a general purpose high speed high torque disc coupling used where minimum coupling weight is desirable. It is available as a standard flexible membrane coupling or in special designs including torsionally tuned, breaker pin, electrically insulated, brake drum and brake disc.

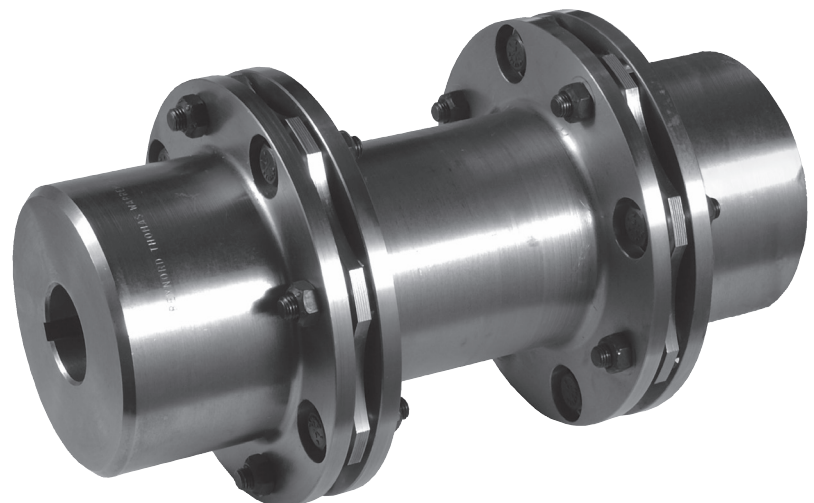

ATEX II 2GD c T5

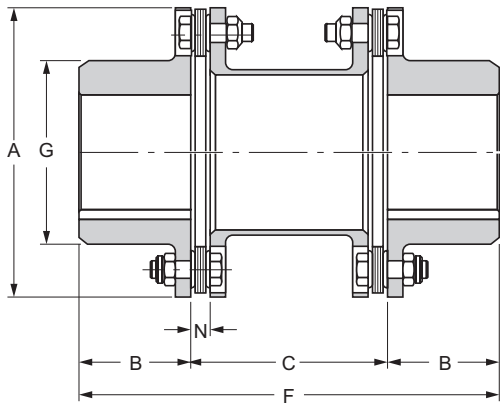

Torque Demands Driven Machine	Typical Application for Electric Motor or Turbine Driven Equipment	Typical Service Factor
	Constant torque such as centrifugal pumps blowers and compressors	1.0
	Continuous duty with some torque variations including plastic extruders and forced draft fans	1.5
	Light shock loads from metal extruders, cooling towers and log haulers	2.0
	Moderate shock loading as expected from a car dumper, stone crusher, vibrating screen	2.5
	Heavy shock load with some negative torques from reciprocating pumps, compressors, reversing turnout tables	3.0
	Frequent torque reversals such as reciprocating compressors with frequent torque reversals which do not necessarily include reverse rotations	Consult REXNORD Engineering

Coupling Size	n max		Max torque		Max. Bore	A	B	C min	C std.	F min	G	N	Weight*	Weight Change per mm of C	WR ² *	WR ² Change per mm of C	Axial Capacity
	not balanced	balanced	Continuous	Peak													
125	5000	15000	305	610	34	94	33	51,6		118	52	6,7	2,2	0,0028	0,002	0,002	±0,91
162	4600	15000	604	1208	50	110	44	51,6		140	70	7,1	3,7	0,0037	0,005	0,003	±0,91
200	4250	15000	1186	2371	58	138	52	66,8		171	83	9,1	6,6	0,0045	0,014	0,007	±0,91
225	4100	14000	1976	3952	70	144	67	69,9		204	96	9,1	8,1	0,0047	0,02	0,008	±0,91
262	3900	13000	3707	7414	84	168	73	81,8		228	114	11,9	13,6	0,0072	0,044	0,015	±1,09
312	3450	11700	5804	11607	97	198	86	95,3		267	133	12,7	22,7	0,0087	0,102	0,027	±1,3
350	3200	10500	7554	15107	110	221	95	105,7		296	146	13,5	31,5	0,0097	0,18	0,037	±1,42
375	3000	9400	11325	22650	120	246	102	116,6		327	165	15,1	44,7	0,0133	0,31	0,061	±1,57
425	2800	8700	15164	30327	130	267	108	125,5	250	341	178	15,9	57,5	0,0173	0,44	0,094	±1,7
450	2700	8100	16982	33963	140	287	114	135,6	250	364	189	18,3	70,7	0,0184	0,66	0,011	±1,83
500	2500	7100	27821	55642	146	327	127	153,2	250	407	213	19,8	102	0,0245	1,25	0,198	±2,08
550	2300	6300	37305	74611	166	367	140	174,8	250	455	240	23	142	0,0387	2,23	0,382	±2,34
600	2150	5700	48980	97960	176	406	152	190,5	250	495	260	24,6	186	0,0430	3,58	0,525	±2,59
700	1950	5000	76191	152383	205	464	178	217,4	300	573	298	30,5	259	0,0714	4,82	1,04	±2,92
750	1850	4600	98096	196191	224	503	191	235	300	617	321	32,3	327	0,0893	7,17	1,5	±3,18
800	1750	4300	121795	243591	241	546	210	254,5	300	675	346	34	413	0,1071	10,8	2,3	±3,45
850	1600	3900	143734	287467	250	584	222	273,1	350	717	368	35,6	503	0,1071	15	2,3	±3,66
925	1500	3600	194656	389312	270	635	241	292,1	500	774	400	38,1	662	0,1429	23,3	4,61	±3,96
1000	900	3250	220173	440347	300	699	267	368	500	902	438	42,9	853	0,1607	36	5,83	±4,37
1100	800	3100	262514	525029	320	741	286	406	600	978	470	44,5	1021	0,1964	49,3	9,15	±4,65
1200	650	2800	320098	640196	345	816	311	432	600	1054	514	50	1365	0,2679	78,8	13,74	±5,16
1300	600	2600	382763	765526	380	876	337	457	700	1131	556	51,6	1660	0,2679	109,6	15,55	±5,54

* Weight (m) and inertia (WR²) calculated at minimum DBSE and maximum bore.

Coupling Size	mm						inch						
	100	140	180	250	300	400	3,5	4	5	5,5	6	7	8
125	•	•											
162	•	•	•						•				
200	•	•							•				
225	•	•	•	•					•				
262		•	•	•					•				
312		•	•	•									•
350			•	•							•		•
375			•	•								•	