

This is the Original Document in English Language



ATEX: In order for this coupling to meet the ATEX requirements, it is mandatory to precisely follow these installation instructions along with the included supplement form 0005-08-51-01. This supplement outlines the ATEX requirements. If the operator does not adhere to these instructions, conformity is immediately invalidated.



- Because of the possible danger to person(s) or property from accidents which may result from improper use or installation of products, it is extremely important to follow the proper selection, installation, maintenance and operational procedures.
- All rotating power transmission products are potentially dangerous and can cause serious injury. They must be properly guarded in compliance with OSHA, ANSI and any other local standards for the speeds and applications in which they are used. It is the responsibility of the user to provide proper guarding.
- For ATEX requirements, the guard must have a minimum of 1 inch (25mm) radial clearance to the couplings major diameter and allow for good ventilation.

Handling Considerations

- The Addax® Composite Coupling is very durable and will provide years of service if handled properly. Minor scuffs and surface abrasions on the spacer will not affect the performance of the coupling.
- Soft spots caused by heavy impact, cuts or gouges are areas of concern. Any time a soft spot is seen; the coupling should be removed from service and replaced.
- The flexible element should be inspected periodically, or after a high torque or misalignment event. If there are protrusions (bumps) on the surface of the flex element, it should be removed from service.

1. Installation Procedure

STEP 1

- 1.1. The Addax® is shipped assembled from the factory. Remove all of hardware and prepare the hubs for installation onto the shaft.
- 1.2. Addax® coupling systems are designed to use a slight slip fit between the hubs and connected equipment shafts. Hubs should be snug but slide freely on connected equipment shafts.
- 1.3. Verify that there are no burrs on the two shaft ends or inside the hub bores or in the key slots. Also, verify that the keys fit the hubs and shafts properly before installation.
- 1.4. Measure the shaft end separation DBSE and verify that it is the same as shown on the Addax Product Drawing.

ATTENTION! The 350 model does not have overload bushings.

STEP 2

- 2.1. Coupling hub installation with Clearance fit
 - 2.1.1. Slide the hubs onto the shaft ends with at least 1 inch of shaft exposed to provide clearance for the spacer installation.
 - 2.1.2. Move one hub into position so the flange face is flush with the shaft end.
 - 2.1.3. Tighten the set screws on one hub only and lock in place. Using a torque wrench, tighten to the values shown in Table 1. Each hub has two set screws, one over the key and one offset
 - 2.1.4. Install the flexible elements using the hardware in the appropriate locations.

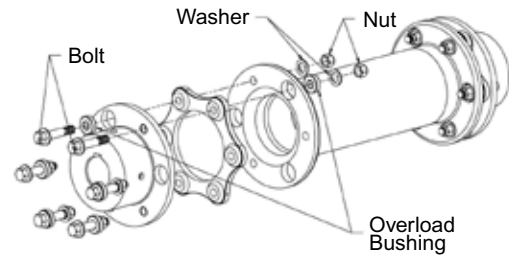

Figure 1 - Coupling assembly

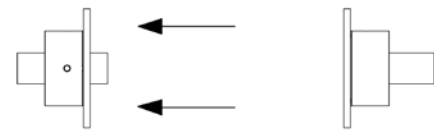

Figure 2 - Slide one hub back

Table 1 - Set screw tightening torque

Set Screw Thread Size	Torque Values		
	inch pounds	foot pounds	Newton meters
1/4 - 20	60	5	7
5/16 - 18	120	10	14
3/8 - 16	192	16	22
1/2 - 13	420	35	47
5/8 - 11	576	48	65
3/4 - 10	744	62	84

2.2. Coupling hub installation with Transitional Fit

2.2.1. A temperature of 120°C is sufficient for these hubs to slide them on the gear & motor shafts.

- Oven Heating: Set the oven thermostat at 120°C and heat the hub at least one hour.
- Oil Bath Heating: If an oil bath is used, the oil must have a flash point of 180°C or higher. Do not rest hubs on the bottom of the container.

2.2.2. Mount the hub on the shaft as quickly as possible to avoid heat loss.

2.2.3. Carefully line up bore and keyway with shaft and key and slide hub onto shaft until hub face is flush with end of shaft.

2.2.4. If it is necessary to drive the hub into position, lightly tap with a soft brass or lead hammer. Avoid excessive pounding which can cause damage to bearings or connected equipment.

2.2.5. Allow the hubs to cool.

2.2.6. Insert setscrews and tighten. Then follow alignment and assembly instructions furnished with the coupling Installation Instructions.

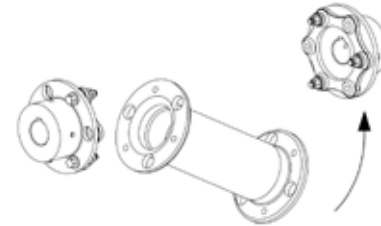

Figure 3 - Position spacer up between hubs.

STEP 3

3.1. Position the spacer between the hubs as shown in Figure 3.

3.2. Align the small holes in the spacer with the holes in the flexible element.

STEP 4

4.1. Slide the other hub into position.

4.2. Temporarily tighten the set screws and lock in place. This hub may need to be repositioned during alignment.



Figure 4 - Slide hub back into position.

STEP 5

- 5.1. All bolts are inserted from the back side of the hubs towards the composite spacer.
- 5.2. Install the overload bushings on the bolts that go through the clearance holes in the hubs.
- 5.3. The other bolts are inserted directly into the bolt holes of the hubs.
- 5.4. All bolts pass through the flexible element and into the spacer flange.
- 5.5. Install overload bushings on the opposing bolts as shown in the figure.
- 5.6. Install washers first then the lock nuts on all bolts.

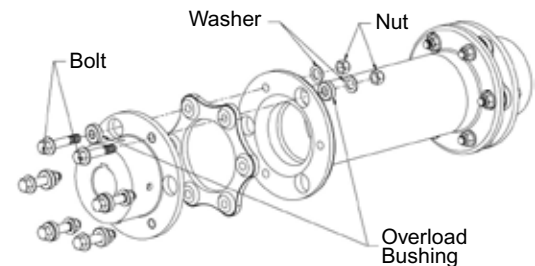

Figure 5 - Coupling assembly

ATTENTION! The 350 model does not have overload bushings.

6. Lock Nut Tightening Torque

6.1. Torque all the lock nuts to the values shown in Table 2. A torque wrench should be used on the nut while holding the head of the bolt to keep it from turning.

7. Set Screw Tightening Torque

7.1. Torque all the set screws to the values shown in Table 1.

Table 2 - Lock Nut Tightening Torque

Coupling Model Number	Torque Values		
	inch pounds	foot pounds	Newton meters
LR_350	400	33	45
LR_375	400	33	45
LR_450	145	12	16
LR_485	240	20	27
LR_650	400	33	45
LR_750/850	540	45	60

Table 3 - Angular and Axial Alignment Limits

Coupling Model Number	Angular Alignment Limits		Axial Alignment Gap Limits	
	inch	MM	inch	MM
LR_350	0.010	.25	0.42 - 0.44	10.7 - 11.2
LR_375	0.010	.25	0.53 - 0.55	13.5 - 14.0
LR_450	0.010	.25	0.42 - 0.44	10.7 - 11.2
LR_485	0.010	.25	0.58 - 0.62	14.9 - 15.9
LR_650	0.020	.51	0.73 - 0.77	18.5 - 19.6
LR_750	0.020	.51	0.85 - 0.89	21.5 - 22.6
LR_850	0.020	.51	0.73 - 0.77	18.5 - 19.6

8. Angular Alignment

ATTENTION! Both the angular and axial alignment must be within the specified limits at both ends of the Addax® coupling before putting it into operation.

- 8.1. Use a sturdy means to squarely attach a dial indicator to the composite spacer shaft. Obtain reading off the outside face of the coupling hub flange as illustrated in the figure above. This can also be done by mounting the indicator on the coupling hub taking readings off the composite spacer shaft flange.
- 8.2. With dial indicator set at zero, check the angular alignment by rotating the shaft around 360° recording the maximum and minimum readings on the dial indicator.
- 8.3. If the range between maximum and minimum is greater than what is shown in Table 3 for your coupling model, then the connecting equipment should be realigned to attain these limits.
- 8.4. Either method shown (Figures 6 and 7) can be used to check angular alignment.

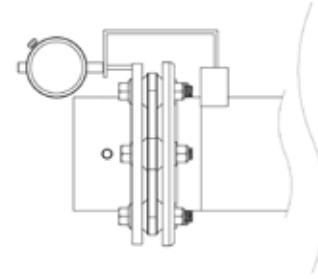

Figure 6 - Check angular alignment using dial indicator method.



Figure 7 - Check angular alignment with Rexnord dial indicator method.

9. Axial Alignment

- 9.1. Measure the gap between the spacer flange and the hub flange on both ends. Use a dial caliper and take 4 readings around the perimeter at 90° intervals. Do this without rotating the coupling.
- 9.2. The average of the 4 readings should be within the gap range shown in Table 3 or the hubs must be repositioned. This procedure should be performed at both ends of the coupling.

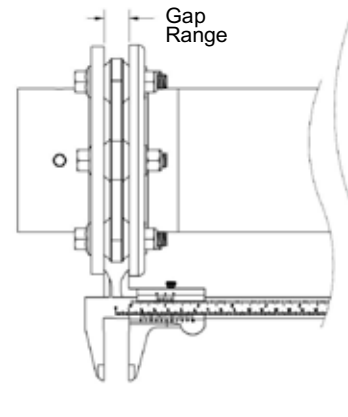

Figure 8 - Check angular alignment with Rexnord dial indicator method.

10. Flexible Element Replacement

- 10.1. If it becomes necessary to replace the flexible element, this can be done without moving the hubs on the shafts. Rexnord recommends that the flex elements and hardware be replaced every 5 years on a preventative maintenance schedule.
- 10.2. Start at one end. Support the composite spacer shaft at that end. Remove all the bolts, locknuts, bushings and washers. This leaves the flexible element loose to slide out.
- 10.3. Repeat step 1 for the other end.
- 10.4. If the flexible elements need to be replaced it is good practice to also replace the hardware at the same time.

Table 4 - Part numbers

Model Number	Flex Element	SS Hardware Kit	Monel Hardware Kit	Backstop Kit	Brakedisc System Kit	Coupling Alignment Kit
350	200917-350	600452-2074		600544-05605	600683-05605	600675 (SAE) or 600675M (Metric)
375	200917-375	600567-2074		600544-05605	600683-05605	
450	200917-045	600567-2056	600567-1056	600544-05605	600683-05605	
485	200917-048	600567-2066	600567-1066	600544-06005	600683-06005	
650	200917-065	600567-2076	600567-1076	600544-07406	600683-07406	
700	200917-070	600567-2096				
850	200917-085	600567-2086	600567-1086	600544-08008	600683-08008	