

**VERTICAL THRUST COUPLINGS**

(Dimensions on Page 2)

The Type V coupling is designed as a rigid connection for the low speed shaft of a reducer and a floating machine member, such as a mixer shaft, where outward or inward thrust loads are present. The coupling carries the torque load and the weight or thrust of the floating member (Figure 1).

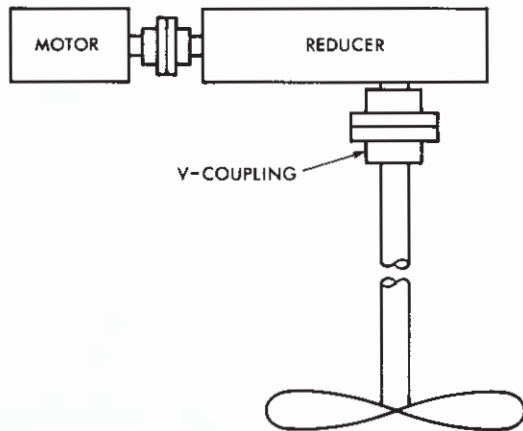

Figure 1

The hubs have male and female registers for accurate alignment.

The driving hub is split to facilitate removal of the driven unit. The driven hub and flange fasteners need not be disturbed when disconnecting driving and driven machinery. The driving hub transmits the power through close tolerance, fitted fasteners to the driven hub.

Thrust rings and dowels are used to support the weight of the floating member. Thrust rings are manufactured in 3 segments for ease of assembly. Consult the Factory for selection and dimensions of thrust rings.

These couplings offer various means of connecting shafts as follows:

- For the customer that CAN NOT remachine his shaft;
- V1 - One hub is split and the other hub is solid with both hubs doweled to the shaft.
- V2 - Both hubs are solid and taper pinned to the shaft.
- V3 - Both hubs are split and straight doweled to the shaft.

- For the customer that CAN remachine his shaft for a thrust ring;
- V4 - Both hubs are split with thrust rings to support the shaft.
- V5 & VS - One hub is split with thrust ring to support the shaft. The other hub is solid and doweled to the shaft. The VS coupling is bored for GD&X & GRX units only.

When a rigid thrust coupling is required for an agitator drive, the following application information is required to quote or ship to your requirements:

1. Horsepower.
2. RPM.
3. Shaft diameters.
4. Required thrust capacity and direction of thrust.
5. Radial force at agitator.
6. Dimension from the center of the coupling fastener flange to the center of the agitator.

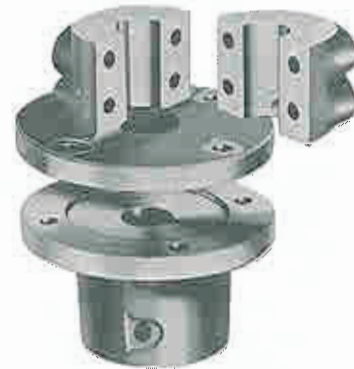

Type V1 with Dowel



Type V5 with Thrust Ring

**Coupling Ratings and Allowable Speeds**

SIZE	Hp per 100 rpm*	Torque Rating lb-in.*	Allow. Speed rpm	Allow. Thrust Capacity lbs.		Allow. Bending Moment lb-in.
				V1 & V3	V2, V4, V5 & VS	
2V	6	3,780	900	2,380	2,380	17,400
3V	12	7,560	900	3,900	3,900	28,700
4V	16	10,080	900	5,800	11,200	34,200
5V	23	14,490	900	7,800	14,000	59,800
6V	46	28,980	900	9,350	18,000	162,000
7V	67	42,210	900	13,000	21,700	179,000
8V	160	100,800	800	15,000	25,000	209,000
9V	251	158,130	700	15,000	29,500	451,000
10V	454	286,020	550	....	39,000	753,000
11V	767	483,210	440	....	50,000	1,310,000
12V	1175	740,250	400	....	60,000	1,540,000

\*No additional service factors are required for agitator or mixer applications.

**Fastener Tightening Torque—lb-in.**

SIZE	2V	3V	4V	5V	6V	7V	8V	9V	10V	11V	12V
Flange	235	360	360	720	2040	2940	2940	6800	12600	22100	23700
Split	145	235	360	720	1290	1290	1430	2160	4340	7600	12000

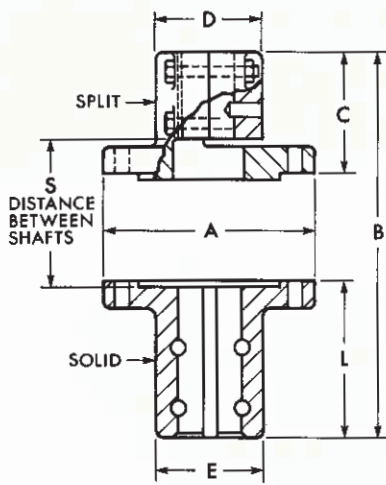

**SIZES 2V1-9V1**

One hub is split and the other hub is solid with both hubs doweled to the shaft.

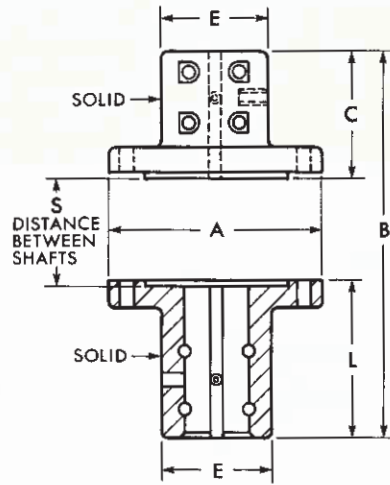

**SIZES 2V2-8V2**

Both hubs are solid and taper pinned to the shaft.

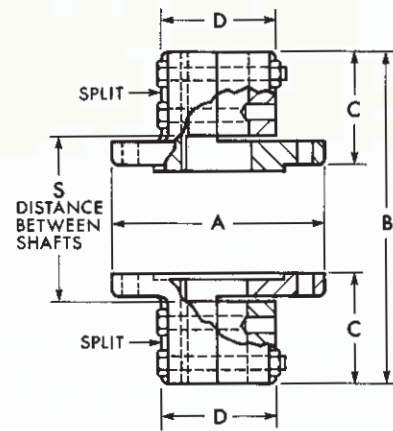

**SIZES 2V3-7V3**

Both hubs are split and straight doweled to the shaft.

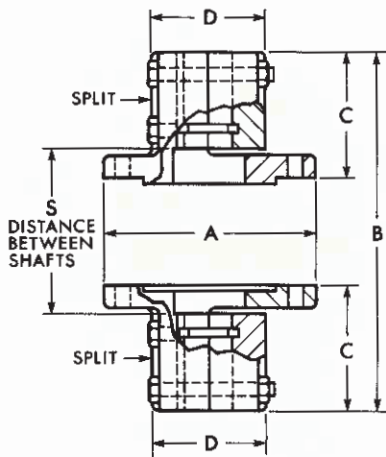

**SIZES 2V4-12V4**

Both hubs are split with thrust rings to support the shaft.

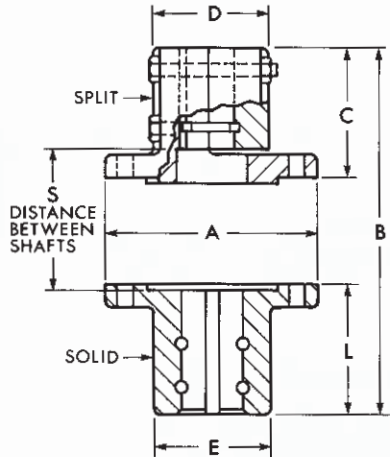

**SIZES 2V5-12V5**

One hub is split with thrust ring to support the shaft. The other hub is solid and doweled to the shaft.

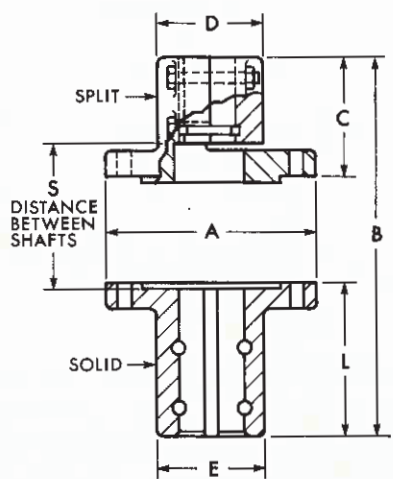

**SIZES 4VS-12VS**

One hub is split with thrust ring to support the shaft. The other hub is solid and doweled to the shaft.

**DIMENSIONS—INCHES**

SIZE ★	Max Bore*		Cplg. Wt. with No Bore-lb				B						C		D	E	L	S		
	Split Hub		Solid Hub	V3 & V4	V1, V5 & VS	V2	A	V3 & V4	V1, V5 & VS	V2	V1, V3, V4, V5 & VS	V2	V2	V1, V5 & VS				V3 & V4		
	V1, V3	V4, V5 & VS																		
2V	1 <sup>1</sup> / <sub>16</sub>	1 <sup>1</sup> / <sub>8</sub>	2 <sup>1</sup> / <sub>8</sub>	16	17	20	5 <sup>1</sup> / <sub>4</sub>	5 <sup>3</sup> / <sub>8</sub>	6 <sup>1</sup> / <sub>16</sub>	6 <sup>5</sup> / <sub>8</sub>	2 <sup>11</sup> / <sub>16</sub>	3 <sup>3</sup> / <sub>8</sub>	2 <sup>7</sup> / <sub>8</sub>	3 <sup>1</sup> / <sub>8</sub>	3 <sup>3</sup> / <sub>8</sub>	1 <sup>1</sup> / <sub>16</sub>	7 <sup>1</sup> / <sub>8</sub>	1 <sup>3</sup> / <sub>8</sub>		
3V	2	1 <sup>1</sup> / <sub>2</sub>	3 <sup>1</sup> / <sub>2</sub>	29	30	32	6 <sup>1</sup> / <sub>2</sub>	6 <sup>3</sup> / <sub>8</sub>	7 <sup>3</sup> / <sub>16</sub>	7 <sup>7</sup> / <sub>8</sub>	3 <sup>3</sup> / <sub>16</sub>	3 <sup>3</sup> / <sub>8</sub>	3 <sup>1</sup> / <sub>2</sub>	3 <sup>3</sup> / <sub>8</sub>	3 <sup>3</sup> / <sub>8</sub>	1 <sup>1</sup> / <sub>16</sub>	1	1 <sup>5</sup> / <sub>8</sub>		
4V	2 <sup>1</sup> / <sub>16</sub>	2 <sup>3</sup> / <sub>16</sub>	2 <sup>1</sup> / <sub>2</sub>	48	50	55	7 <sup>1</sup> / <sub>2</sub>	8 <sup>3</sup> / <sub>8</sub>	8 <sup>11</sup> / <sub>16</sub>	8 <sup>7</sup> / <sub>8</sub>	4 <sup>3</sup> / <sub>16</sub>	4 <sup>1</sup> / <sub>2</sub>	4 <sup>1</sup> / <sub>4</sub>	4 <sup>5</sup> / <sub>8</sub>	4 <sup>1</sup> / <sub>2</sub>	1 <sup>1</sup> / <sub>16</sub>	1 <sup>1</sup> / <sub>8</sub>	1 <sup>7</sup> / <sub>8</sub>		
5V	2 <sup>1</sup> / <sub>16</sub>	2 <sup>1</sup> / <sub>2</sub>	3 <sup>1</sup> / <sub>4</sub>	73	70	70	8 <sup>3</sup> / <sub>8</sub>	9 <sup>7</sup> / <sub>8</sub>	9 <sup>15</sup> / <sub>16</sub>	9 <sup>7</sup> / <sub>8</sub>	4 <sup>13</sup> / <sub>16</sub>	5	5	4 <sup>7</sup> / <sub>8</sub>	5	1 <sup>1</sup> / <sub>16</sub>	1 <sup>1</sup> / <sub>4</sub>	2 <sup>1</sup> / <sub>8</sub>		
6V	3 <sup>1</sup> / <sub>16</sub>	3 <sup>1</sup> / <sub>8</sub>	4	128	125	130	9 <sup>7</sup> / <sub>8</sub>	11 <sup>1</sup> / <sub>2</sub>	12 <sup>1</sup> / <sub>4</sub>	12 <sup>3</sup> / <sub>8</sub>	5 <sup>3</sup> / <sub>4</sub>	6	5 <sup>5</sup> / <sub>8</sub>	6	6 <sup>1</sup> / <sub>2</sub>	1 <sup>1</sup> / <sub>16</sub>	1 <sup>7</sup> / <sub>16</sub>	2 <sup>1</sup> / <sub>2</sub>		
7V	3 <sup>1</sup> / <sub>16</sub>	3 <sup>3</sup> / <sub>16</sub>	4 <sup>1</sup> / <sub>2</sub>	171	170	180	10 <sup>3</sup> / <sub>4</sub>	13 <sup>1</sup> / <sub>4</sub>	13 <sup>5</sup> / <sub>8</sub>	13 <sup>3</sup> / <sub>8</sub>	6 <sup>5</sup> / <sub>8</sub>	6 <sup>3</sup> / <sub>4</sub>	6 <sup>5</sup> / <sub>8</sub>	6 <sup>3</sup> / <sub>4</sub>	7	1 <sup>1</sup> / <sub>16</sub>	1 <sup>7</sup> / <sub>16</sub>	2 <sup>3</sup> / <sub>4</sub>		
8V	4 <sup>3</sup> / <sub>4</sub>	4 <sup>3</sup> / <sub>8</sub>	5 <sup>3</sup> / <sub>4</sub>	256	280	290	12 <sup>1</sup> / <sub>4</sub>	16	17	16 <sup>5</sup> / <sub>16</sub>	8	8	7 <sup>1</sup> / <sub>2</sub>	8 <sup>1</sup> / <sub>4</sub>	9	1 <sup>1</sup> / <sub>16</sub>	1 <sup>3</sup> / <sub>4</sub>	3		
9V	5 <sup>5</sup> / <sub>16</sub>	4 <sup>9</sup> / <sub>16</sub>	6 <sup>1</sup> / <sub>2</sub>	415	440	...	14 <sup>3</sup> / <sub>4</sub>	18 <sup>1</sup> / <sub>2</sub>	19 <sup>5</sup> / <sub>8</sub>	...	9 <sup>1</sup> / <sub>4</sub>	9 <sup>9</sup> / <sub>16</sub>	8 <sup>3</sup> / <sub>4</sub>	9 <sup>1</sup> / <sub>4</sub>	10 <sup>3</sup> / <sub>8</sub>	...	2	3 <sup>1</sup> / <sub>2</sub>		
10V	...	6	7 <sup>1</sup> / <sub>2</sub>	780	715	...	17 <sup>3</sup> / <sub>4</sub>	21	21 <sup>3</sup> / <sub>4</sub>	...	10 <sup>1</sup> / <sub>2</sub>	10 <sup>11</sup> / <sub>16</sub>	11	11	11 <sup>1</sup> / <sub>4</sub>	...	2 <sup>1</sup> / <sub>4</sub>	4		
11V	...	7 <sup>1</sup> / <sub>2</sub>	9 <sup>1</sup> / <sub>2</sub>	1236	1265	...	21 <sup>1</sup> / <sub>2</sub>	24 <sup>3</sup> / <sub>4</sub>	26 <sup>3</sup> / <sub>8</sub>	...	12 <sup>3</sup> / <sub>8</sub>	12 <sup>5</sup> / <sub>8</sub>	13 <sup>1</sup> / <sub>2</sub>	13 <sup>1</sup> / <sub>2</sub>	13 <sup>3</sup> / <sub>4</sub>	...	2 <sup>1</sup> / <sub>16</sub>	4 <sup>1</sup> / <sub>4</sub>		
12V	...	9	11 <sup>1</sup> / <sub>2</sub>	2028	2070	...	25	29 <sup>3</sup> / <sub>4</sub>	31 <sup>1</sup> / <sub>4</sub>	...	14 <sup>7</sup> / <sub>8</sub>	15 <sup>3</sup> / <sub>16</sub>	16	16	16 <sup>3</sup> / <sub>8</sub>	...	2 <sup>3</sup> / <sub>4</sub>	4 <sup>3</sup> / <sub>4</sub>		

\* Dimensions are for reference only and are subject to change without notice unless certified.  
 \* Solid hubs are furnished with an average interference fit of .0005" per inch of shaft diameter, unless otherwise specified.  
 Split hubs are furnished with an interference fit of .000" to .002" for all shaft sizes.  
 Only V2 coupling hubs are bored for CLEARANCE FIT with two set screws; one over keyway and the other 90° to keyway.