

How to Use This Manual

This manual provides detailed instructions on maintenance, lubrication, installation, and parts identification. Use the table of contents below to locate required information.

Table of Contents

Introduction	Page 1
Lube Fittings	Page 1
Limited End Float	Page 1
Lubrication	Pages 1-2
Installation & Alignment Instructions.	Pages 2-4
Annual Maintenance, Relube & Disassembly.	Page 5
Installation & Alignment Data.	Page 6
Parts Identification & Parts Interchangeability.	Page 7

CAREFULLY FOLLOW THE INSTRUCTIONS IN THIS MANUAL FOR OPTIMUM PERFORMANCE AND TROUBLE FREE SERVICE.

INTRODUCTION

This manual applies to Sizes 1020T thru 1140T and 20T thru 140T31 standard Falk Steelflex disassembled Spacer Couplings. Unless otherwise stated, information for Sizes 1020T thru 1140T applies to Sizes 20T thru 140T respectively, e.g. 1020T = 20T, 1100T = 100T, etc. For couplings furnished with special features, refer to assembly drawing furnished with coupling for proper assembly arrangement and any additional installation or maintenance requirements. The Spacer Assembly permits installation (or removal, as shown on Page 4) without disturbing coupling cover, grid, grease or connected equipment. These couplings are designed to operate in either the horizontal or vertical position without modification. However, for vertical applications, the match mark shown on Page 4 must be up. These couplings are supplied with one set of inch series cover fasteners and one set of metric cover fasteners. Use either set of fasteners, depending on your preference. Refer to Page 7 for part interchangeability.

The performance and life of the couplings depend largely upon how you install and service them.

WARNING: Consult applicable local and national safety codes for proper guarding of rotating members. Lockout starting switch of prime mover and remove all external loads from drive before installing or servicing couplings. Observe all safety rules when installing or servicing couplings.

LUBE FITTINGS

Cover halves have $\frac{1}{8}$ NPT lube holes. Use a standard grease gun and lube fitting as instructed on Page 5.

LIMITED END FLOAT

When electric motors, generators, and other machines are fitted with sleeve or straight roller bearings, limited axial end float kits are recommended for protecting the bearings. Falk Steelflex couplings are easily modified to limit end float; refer to Manual 428-820 for instructions. NOTE: To remove or install a spacer assembly (as shown on Page 4) fitted with limited end float, the sleeve bearing shaft must have enough axial movement to separate and clear the shaft hub registers.

LUBRICATION

Adequate lubrication is essential for satisfactory operation. Page 2 provides a list of typical lubricants and specifications for general purpose greases. Because of its superior lubricating characteristics and low centrifuge properties, Falk Long Term Grease (LTG) is highly recommended. Sizes 1020T to 1090T31 are furnished with a pre-measured amount of grease for each coupling. The grease can be ordered for larger size couplings.

The use of general purpose grease requires re-lubrication of the coupling at least annually.

Long Term Grease (LTG)

The high centrifugal forces encountered in couplings separate the base oil and thickener of general purpose greases. Heavy thickener, which has no lubrication qualities, accumulates in the grid-groove area of Steelflex couplings resulting in premature hub or grid failure unless periodic lubrication cycles are maintained.

Falk Long Term Grease (LTG) was developed specifically for couplings. It resists separation of the oil and thickener. The consistency of Falk LTG changes with operating conditions. As manufactured it is an NLG1#1/2 grade. Working of the lubricant under actual service conditions causes it to become semifluid while the grease near the seals will set to a heavier grade, helping to prevent leakage.

LTG is highly resistant to separation, easily out performing all other lubricants tested. The resistance to separation allows the lubricant to be used for relatively long periods of time.

Steelflex couplings initially lubricated with LTG will not require re-lubrication until the connected equipment is stopped for servicing. If a coupling leaks grease, is exposed to extreme temperatures, excessive moisture, or experiences frequent reversals, more frequent lubrication may be required.

Although LTG grease is compatible with most other coupling greases, the mixing of greases may dilute the benefits of LTG.

WARNING: Mixing grid coupling components from different manufacturers may cause premature failure and personal or property damage from flying debris.

USDA Approval

LTG has the United States Department of Agriculture Food Safety & Inspection Service approval for applications where there is no possibility of contact with edible products. (H-2 ratings).

CAUTION: Do not use LTG in bearings.

Specifications — Falk LTG

The values shown are typical and slight variations are permissible.

AMBIENT TEMPERATURE RANGE — -20°F (-29°C) to 250°F (121°C). Min. Pump = 20°F (-7°C)

MINIMUM BASE OIL VISCOSITY — 3300SSU (715cST) @ 100°F (38°C)

THICKENER — Lithium & soap/polymer.

CENTRIFUGE SEPARATION CHARACTERISTICS — ASTM #D4425 (Centrifuge Test) — K36 = 2/24 max., very high resistance to centrifuging.

NLGI GRADE (ASTM D-217) — $1/2$

CONSISTENCY (ASTM D-217) — 60 stroke worked penetration value in the range of 315 to 360 measured at 77°F (25°C)

MINIMUM DROPPING POINT — 350°F (177°C) minimum

MINIMUM TIMKEN O.K. LOAD — 40 lbs.

ADDITIVES — Rust and oxidation inhibitors that do not corrode steel or swell or deteriorate synthetic seals.

Packaging

14 oz (0,4 kg) CARTRIDGES — Individual or case lots of 10 or 60.

35 lb. (16 kg) PAIL, 120 lb. (54 kg) KEG & 400 lb. (181 kg) DRUMS.

General Purpose Grease

ANNUAL LUBRICATION — The following specifications and lubricants for general purpose grease apply to Falk Steelflex couplings that are lubricated annually and operate within ambient temperatures of 0°F to 150°F (-18°C to 66°C). For temperatures beyond this range (see Table 1), consult the Factory.

If a coupling leaks grease, is exposed to extreme temperatures, excessive moisture or experiences frequent reversals, more frequent lubrication may be required.

General Purpose Greases Meeting Falk Specifications

Lubricants listed below are typical products only and should not be construed as exclusive recommendations.

TABLE 1 — General Purpose Greases *

Ambient Temperature Range	0°F to 150°F (-18°C to 66°C)	-30°F to 100°F (-34°C to 38°C)
Manufacturer	Lubricant †	Lubricant †
Amoco Oil Co. BP Oil Co. Chevron U.S.A. Inc. Citgo Petroleum Corp.	Amolith Grease #2 Energrease LS-EP2 Dura-Lith EP2 Premium Lithium Grease EP2	Amolith Grease #2 Energrease LS-EP1 Dura-Lith EP1 Premium Lithium Grease EP1
Conoco Inc.	EP Conolith Grease #2	EP Conolith Grease #2
Exxon Company, USA E.F. Houghton & Co. Imperial Oil Ltd. Kendall Refining Co.	Unirex N2 Cosmolube 2 Unirex N2L Lithium Grease L421	Unirex N2 Cosmolube 1 Unirex N2L Lithium Grease L421
Keystone Div. (Pennwalt) Lyondell Petrochemical (ARCO)	81 EP-2 Litholine H EP 2 Grease	81 EP-1 Litholine H EP 2 Grease
Mobil Oil Corp. Petro-Canada Products	Mobilux EP111 Multipurpose EP2	Mobilith AW1 Multipurpose EP1
Phillips 66 Co. Shell Oil Co. Shell Canada Ltd. Sun Oil Co.	Philube Blue EP Alvania Grease 2 Alvania Grease 2 Ultra Prestige 2EP	Philube Blue EP Alvania Grease 2 Alvania Grease 2 Ultra Prestige 2EP
Texaco Lubricants Unocal 76 (East & West) Valvoline Oil Co.	Starplex HD2 Unoba EP2 Multilube Lithium EP Grease	Multifak EP2 Unoba EP2 ...

* Grease application or re-lubrication should be done at temperatures above 20°F (-7°C). If grease must be applied below 20°F (-7°C), consult the Factory.

† Lubricants listed may not be suitable for use in the food processing industry; check with lube manufacturer for approved lubricants.

Specifications – General Purpose Coupling Lubricants

The values shown are typical and slight variations are permissible.

DROPPING POINT — 300°F (149°C) or higher.

CONSISTENCY — NLGI No. 2 with 60 stroke worked penetration value in the range of 250 to 300.

SEPARATION & RESISTANCE — Low oil separation rate and high resistance to separation from centrifuging.

LIQUID CONSTITUENT — Possess good lubricating properties ... equivalent to a high quality, well refined petroleum oil.

INACTIVE — Must not corrode steel or cause swelling or deterioration of synthetic seals.

CLEAN — Free from foreign inclusions.

INSTALLATION OF TYPE T31 STEELFLEX TAPERED GRID COUPLINGS

Installation

Only standard mechanics tools, wrenches, a straight edge and feeler gauges are required to install Falk Steelflex couplings. Clean all parts using a nonflammable solvent. Check hubs, shafts, and keyways for burrs. Coupling Sizes 1020T thru 1090T are generally furnished for CLEARANCE FIT with setscrew over the keyway. Sizes 1100T and larger are furnished for an INTERFERENCE FIT without a setscrew.

CLEARANCE FIT HUBS — Clean all parts using a nonflammable solvent. Check hubs, shafts and keyways for burrs. Do not heat clearance fit hubs. Install keys, mount hubs with flange face flush with shaft ends or as otherwise specified and tighten setscrews.

INTERFERENCE FIT HUBS — Furnished without setscrews. Heat hubs to 275°F (135°C) using an oven, torch, induction heater or an oil bath. To prevent seal damage, DO NOT heat hubs beyond a maximum temperature of 400°F (205°C).

When an oxyacetylene or blow torch is used, use an excess acetylene mixture. Mark hubs near the center of their length in several places on hub body with a temperature sensitive crayon, 275°F (135°C) melt temperature. Direct flame towards hub bore using constant motion to avoid overheating an area.

WARNING: If an oil bath is used, the oil must have a flash point of 350°F (177°C) or higher. Do not rest hubs on the bottom of the container. Do not use an open flame in a combustible atmosphere or near combustible materials.

Heat hubs as instructed above. Mount hubs as quickly as possible with hub face flush with shaft end. Allow hubs to cool before proceeding. Insert setscrews (if required) and tighten.

Maximize Performance & Life

The performance and life of couplings depend largely upon how you install and maintain them. Before installing couplings, make certain that foundations of equipment to be connected meet manufacturers' requirements. Check for soft foot. The use of stainless steel shims is recommended. Measuring misalignment and positioning equipment within alignment tolerances is simplified with an alignment computer. These calculations can also be done graphically or mathematically.

Alignment is shown using spacer bar and straight edge. This practice has proven to be adequate for many industrial

applications. However, for superior final alignment, the use of dial indicators (see Manual 458-834 for instructions), lasers, alignment computers or graphical analysis is recommended.

Installation of Disassembled Spacer Assembly

1 — Mount Shaft Hubs

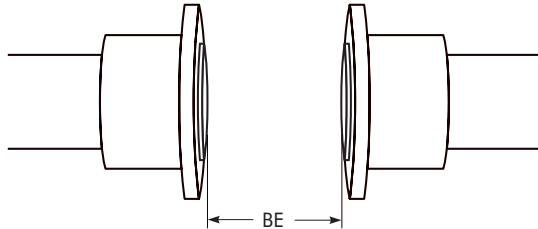

Lock out starting switch of prime mover. Heat interference fit hubs as previously instructed. Mount shaft hubs on their respective shafts so that hub face is flush with the end of the shaft unless otherwise indicated. Position drives for approximate distance between shaft ends with minimum angular and offset misalignment.

2 — Mount Each Half Spacer

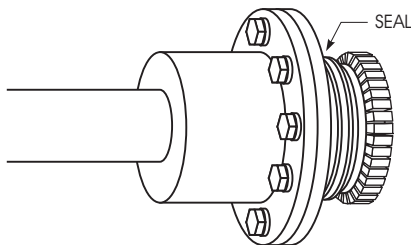

Stretch the seal and carefully roll it over hub teeth into position. Carefully position each half spacer on register of flanged hubs and fasten parts together. Torque fasteners to specifications in Table 2 on Page 6.

3 — Gap & Angular Alignment

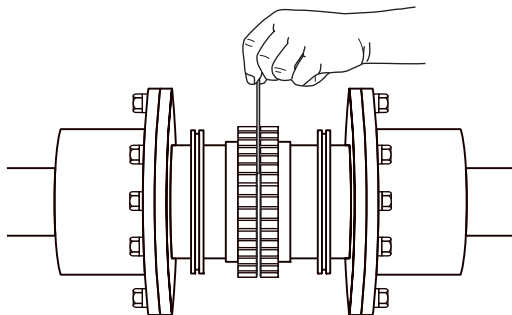

Use a spacer bar equal in thickness to the gap specified in Table 2 on Page 6. Insert bar, as shown above, to same depth at 90° intervals and measure clearance between bar and hub

face with feelers. The difference in minimum and maximum measurements must not exceed the ANGULAR installation limits specified in Table 2 on Page 6.

4 — Offset Alignment

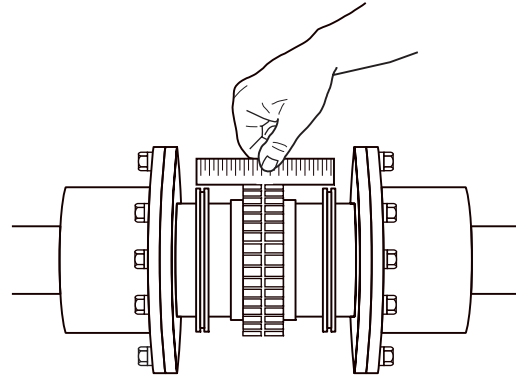

Align so that a straight edge rests squarely (or within the limits specified in Table 2, Page 6) on both hubs as shown above and also at 90° intervals. Check with feelers. The clearance must not exceed the PARALLEL OFFSET installation limits specified in Table 2 on Page 6. Tighten all foundation bolts and repeat Steps 3 and 4. Realign coupling if necessary.

5 — Insert Grid

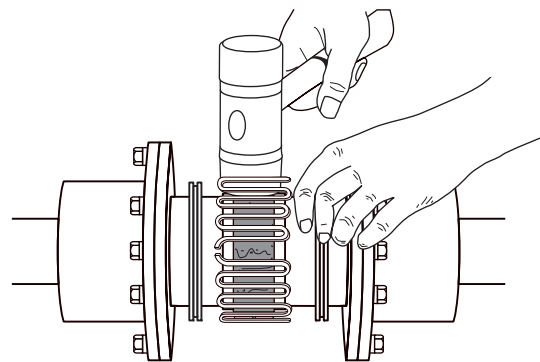
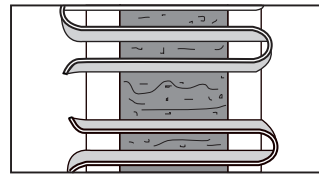

Pack gap and grooves with lubricant before inserting grid. When grids are furnished in two segments, install them so that all cut ends extend in the same direction (as detailed in the inset picture above). This will assure correct grid contact with the lug in the cover and permit cover installation. Spread the grid slightly to pass it over the coupling teeth and then seat it with a soft mallet.

6 — Pack with Grease & Assemble Covers

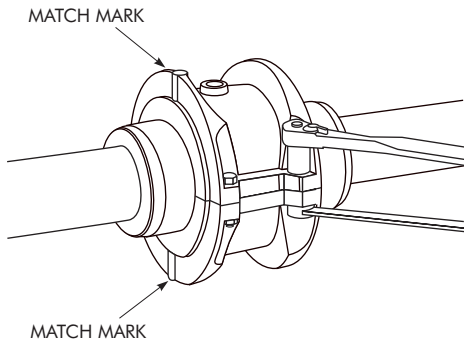
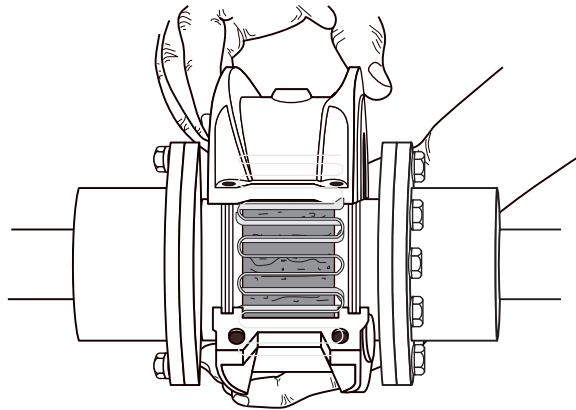

Pack the spaces between and around the grid with as much lubricant as possible and wipe off excess flush with top of grid. Position seals on hubs to line up with grooves in cover. Position gaskets on flange of lower cover half and assemble covers so that the match marks are on the same side (see above). If shafts are not level (horizontal) or coupling is to be used vertically, assemble cover halves with the lug and match mark UP or on the high side. Push gaskets in until they stop

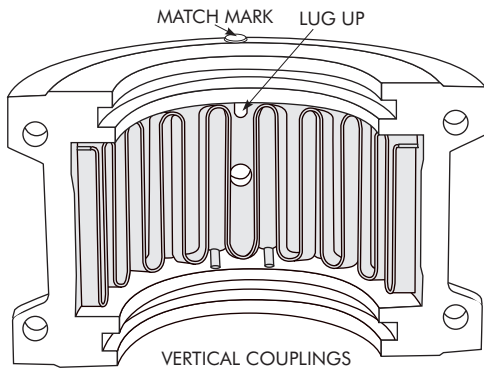

against the seals and secure cover halves with fasteners, tighten to torque specified in Table 2 on Page 6. Make sure gaskets stay in position during tightening of fasteners.

CAUTION: Make certain lube plugs are installed before operating.

Removal & Installation of Spacer Assembly

Remove Spacer Assembly

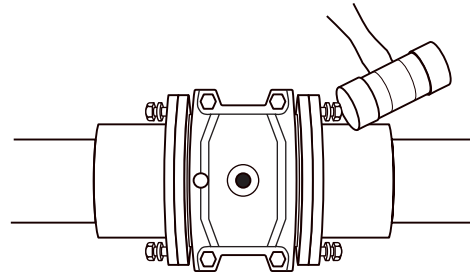

Remove pipe plugs and all but two fasteners opposite each other in each hub. Loosen these about one-quarter inch and tap them with a mallet to disengage Steelflex Spacer from the Shaft hubs. Remove fasteners and Spacer.

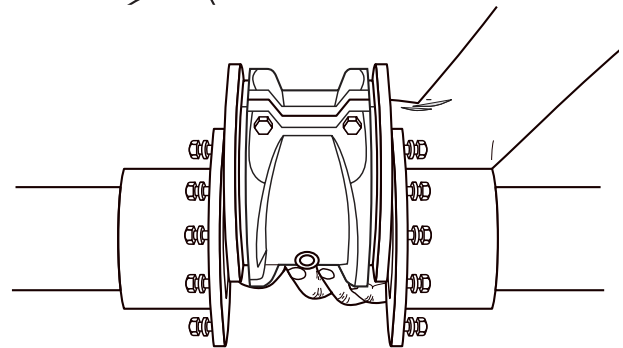
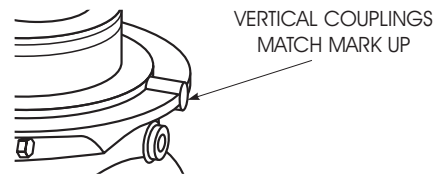

Insert Steelflex Spacer

Insert fasteners as shown – do not allow them to protrude beyond flange face. Remove pipe plugs to vent and compress spacer to eliminate its gap. Then insert between shaft hubs. Carefully engage the hub registers and then alternately tighten fasteners. Torque to specifications in Table 2 on Page 6. Replace pipe plugs.

ANNUAL MAINTENANCE

For extreme or unusual operating conditions, check coupling more frequently.

1. Check alignment per steps on Page 3. If the maximum operating misalignment limits are exceeded, realign the coupling to the recommended installation limits. See Table 2 on Page 6 for installation and operating alignment limits.
2. Check tightening torques of all fasteners.
3. Inspect seal ring and gasket to determine if replacement is required. If leaking grease, replace.
4. When connected equipment is serviced, disassemble the coupling and inspect for wear. Replace worn parts. Clean grease from coupling and re-pack with new grease. Install coupling using new gasket as instructed in this manual.

Periodic Lubrication

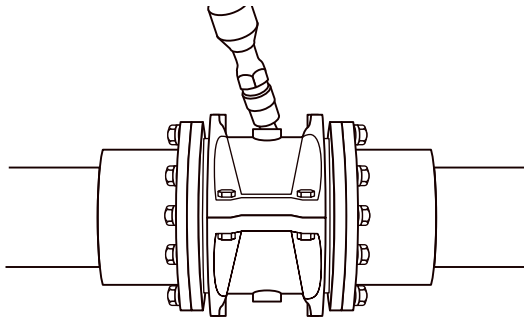

The required frequency of lubrication is directly related to the type of lubricant chosen, and the operating conditions. Steelflex couplings lubricated with common industrial lubricants, such as those shown in Table 1, should be relubed annually. The use of Falk Long Term Grease (LTG) will allow relube intervals to be extended to beyond five years. When relubing, remove both lube plugs and insert lube fitting. Fill with recommended lubricant until an excess appears at the opposite hole. **CAUTION:** Make certain all plugs have been inserted after lubricating.

Coupling Disassembly & Grid Removal

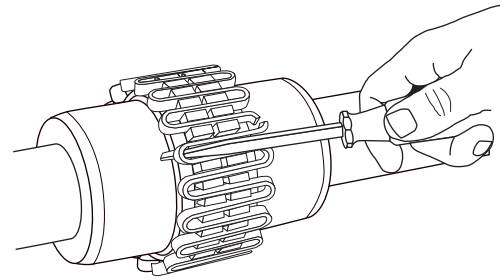

Whenever it is necessary to disconnect the coupling, remove the cover halves and grid. A round rod or screwdriver that will conveniently fit into the open loop ends of the grid is required. Begin at the open end of the grid section and insert the rod or screwdriver into the loop ends. Use the teeth adjacent to each loop as a fulcrum and pry the grid out radially in even, gradual stages, proceeding alternately from side to side.

INSTALLATION & ALIGNMENT DATA

Maximum life and minimum maintenance for the coupling and connected machinery will result if couplings are accurately aligned. Coupling life expectancy between initial alignment and maximum operating limits is a function of load, speed and lubrication. Maximum operating values listed in Table 2 are based on cataloged allowable rpm.

Values listed are based upon the use of standard coupling components, standard assemblies and cataloged allowable speeds.

Values may be combined for an installation or operating condition.

Example: 1060T max. operating misalignment is .016" parallel plus .018" angular.

NOTE: For applications requiring greater misalignment, refer application details to the Factory.

Angular misalignment is dimension X minus Y as illustrated below.

Parallel misalignment is distance P between the hub center lines as illustrated below.

End float (with zero angular and parallel misalignment) is the axial movement of the hub(s) within the cover(s) measured from "O" gap.

ANGULAR MISALIGNMENT

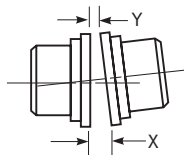

PARALLEL OFFSET MISALIGNMENT

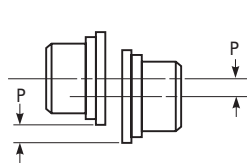

END FLOAT

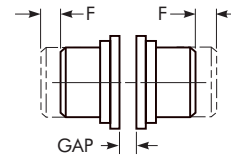

TABLE 2 — Misalignment & End Float

SIZE	Installation Limits						Operating Limits						Fastener Tightening Torque Values			Allow Speed (rpm)	Lube Wt	
	Parallel Offset-P		Angular (x-y)		Hub Gap ± 10%		Parallel Offset-P		Angular (x-y)		End Float Physical Limit (Min) 2 x F		Cover		Flange		lb	kg
	Max Inch	Max mm	Max Inch	Max mm	Inch	mm	Max Inch	Max mm	Max Inch	Max mm	Inch	mm	In. Series Fasteners (lb-in)	Metric Fasteners (Nm)	In. Series Fasteners (lb-in)			
1020T	.006	0,15	.003	0,08	.188	5	.012	0,30	.010	0,25	.210	5,33	100	11,3	120	3600	.06	0,03
1030T	.006	0,15	.003	0,08	.188	5	.012	0,30	.012	0,30	.198	5,03	100	11,3	120	3600	.09	0,04
1040T	.006	0,15	.003	0,08	.188	5	.012	0,30	.013	0,33	.211	5,36	100	11,3	120	3600	.12	0,05
1050T	.008	0,20	.004	0,10	.188	5	.016	0,41	.016	0,41	.212	5,38	200	23,6	250	3600	.15	0,07
1060T	.008	0,20	.005	0,13	.188	5	.016	0,41	.018	0,46	.258	6,55	200	23,6	440	3600	.19	0,09
1070T	.008	0,20	.005	0,13	.188	5	.016	0,41	.020	0,51	.259	6,58	200	23,6	440	3600	.25	0,11
1080T	.008	0,20	.006	0,15	.188	5	.016	0,41	.024	0,61	.288	7,32	200	23,6	825	3600	.38	0,17
1090T	.008	0,20	.007	0,18	.188	5	.016	0,41	.028	0,71	.286	7,26	200	23,6	1640	3600	.56	0,25
1100T	.010	0,25	.008	0,20	.250	6	.020	0,51	.033	0,84	.429	10,90	312	35	2940	2440	.94	0,43
1110T	.010	0,25	.009	0,23	.250	6	.020	0,51	.036	0,91	.429	10,90	312	35	2940	2250	1.1	0,51
1120T	.011	0,28	.010	0,25	.375	10	.022	0,56	.040	1,02	.556	14,12	650	73	4560	2025	1.6	0,74
1130T	.011	0,28	.012	0,30	.375	10	.022	0,56	.047	1,19	.551	14,00	650	73	6800	1800	2.0	0,91
1140T	.011	0,28	.013	0,33	.375	10	.022	0,56	.053	1,35	.571	14,50	650	73	8900	1650	2.5	1,14

TABLE 3 — Coupling Cover Fastener Identification

SIZE	INCH SERIES FASTENERS				METRIC FASTENERS	
	Old Style		New Style			
1020-1070T10		SAE Grade 8 †		SAE Grade 8		Property Class 10.9
1080-1090T10		SAE Grade 8		SAE Grade 8		Property Class 10.9
1100-1140T10		SAE Grade 5		SAE Grade 5		Property Class 8.8

† Older style covers, Sizes 1020T10 thru 1070T10 must utilize socket head cap screws and locknuts held by the cover.

PARTS IDENTIFICATION

All coupling parts have identifying part numbers as shown below. Parts are interchangeable between the 10 series and 1000 series spacer couplings. However, to utilize the higher 1000 series ratings, the 1000T – Blue Grid, Spacer Hubs, Shaft Hubs and Hardware must be used. When ordering parts, always SPECIFY SIZE and TYPE. Sizes 80 through 140T10 covers have been manufactured with two and three ribs; DO NOT mix these cover halves.

PARTS INTERCHANGEABILITY

Parts are interchangeable between Sizes 20T and 1020T, 30T and 1030T, etc. except as noted.

GRIDS — Size 1020T thru 1140T Steelflex couplings use blue grids. Older models, 20T thru 140T, use orange grids.

CAUTION: Blue grids may be used in all applications, but DO NOT substitute orange grids for blue.

COVERS — **CAUTION:** DO NOT mix cover halves of different designs. Sizes 1020T thru 1070T10 covers have been manufactured in several different two-rib designs and 80T thru 140T covers have been manufactured with two and three ribs.

HARDWARE — Older style covers, Sizes 1020T10 thru 1070T10, utilized socket head cap screws with captured locknuts. The new style covers use hex head cap screws (either inch or metric) and unrestrained locknuts. Specify either inch series SOCKET head or inch or metric series HEX head cap screws when ordering replacement parts.

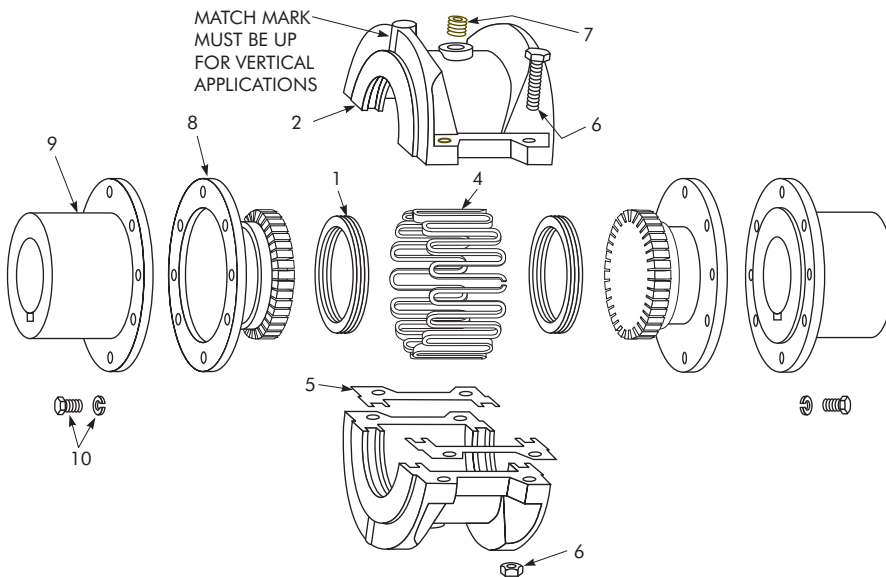

PART DESCRIPTION

1. Seal (T10)
2. Cover (T10)
4. Grid
5. Gasket (T10)
6. Fasteners (T10) — Coupling supplied with both inch series fasteners and metric fasteners.
7. Lube Plug
8. T31 Spacer Hub (Specify Length)
9. Shaft Hub
10. Flange Fastener

PART NUMBER LOCATION

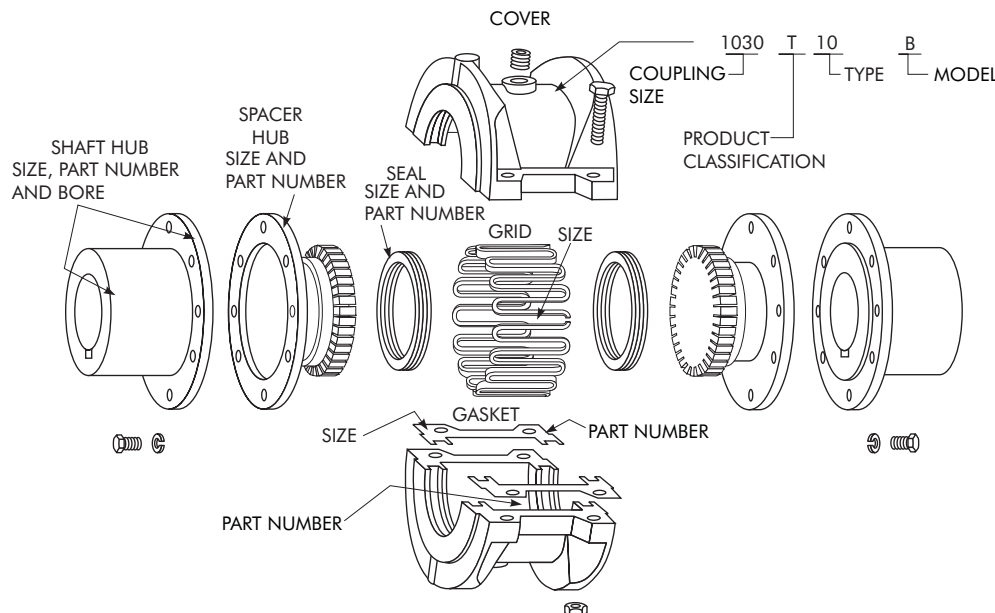

ORDER INFORMATION

1. Identify part(s) required by name above.
2. Furnish the following information.

EXAMPLE:

Coupling Size: 1030
Coupling Type: T31
Model: B
Bore: 1.375
Keyway: .375 x .187
Distance Between Shaft Ends (BE): 5.0

3. Price parts from appropriate Price List and discount sheet.