



Shaft-Mounted Planetgear (SMP)

(Inch)



Shaft-Mounted Planetgear (SMP)



To learn more about the Rexnord® Shaft-Mounted Planetgear™ (SMP),
visit www.rexnord.com, where you'll find:

Product information • Brochures • Catalogs • Manuals

866-REXNORD/866-739-6673 (toll-free within the U.S.) or 414-643-2366 (Outside the U.S.)

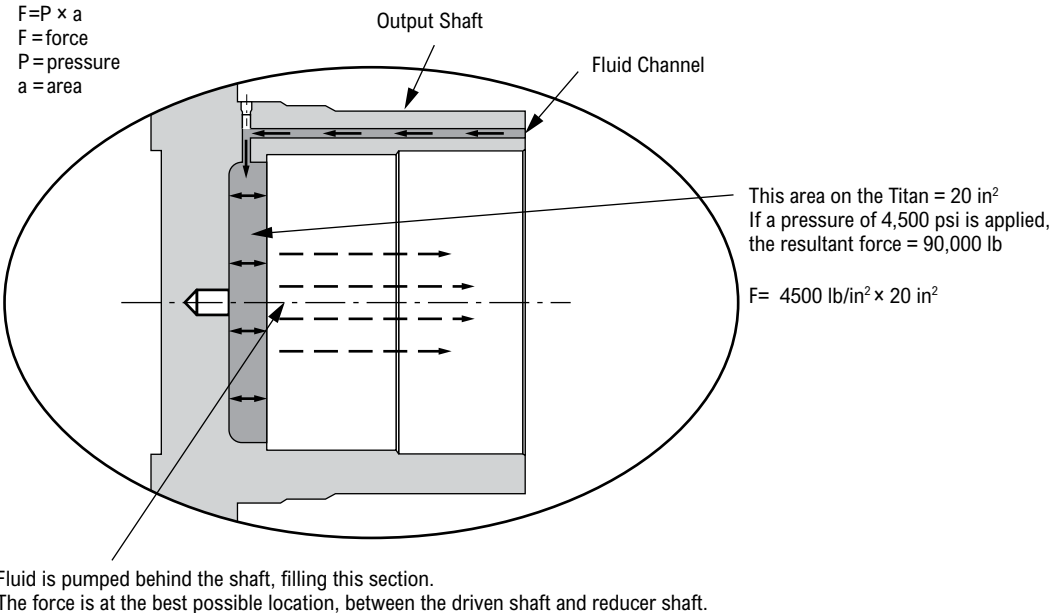

Table Of Contents

| DESCRIPTION | PAGE |
|--|-------------|
| Rexnord Planetgear Basic Information | 4, 5 |
| How to Select Gear Drives | 6, 7 |
| Service Factors | 8, 9 |
| Nomenclature | 10 |
| PLANETGEAR RATINGS | |
| Orion Ratings | 11 |
| Titan Ratings | 12 |
| Jupiter Ratings | 13 |
| Gemini Ratings | 14 |
| Hercules Ratings | 15 |
| PLANETGEAR TECHNICAL DATA | |
| Thermal Horsepower Limits | 16 |
| Ambient Temperature Adjustment Factor & Overhung Load Capacity | 17 |
| PLANETGEAR DIMENSIONS & MAINTENANCE | |
| One and Two-Step Shaft | 18 |
| One and Two-Step Shaft — Heavy-Duty | 19 |
| Top Motor Mount & Torque Arm | 20 |
| Belt Guards | 21 |
| Integral | 22 |
| Scoop | 23 |
| Installation and Maintenance Information | 24, 25 |
| Gear Drive Order Form | 26 |

Rexnord Planetgear Basic Information

Hydraulic Remove System (Hydro-Advantage)



Rexnord Planetgear Basic Information

Proven, Reliable Gear Performance

With Planetgear reducers, self-aligning planet carriers float radially and axially to provide perfect alignment of the gear train. Unlike "traditional gears", which have only one point of contact per reduction, Planetgear transmits the torque through three points of contact between sun gears and planet gears. The floating gear train ensures equal loading among the three points. State-of-the-art heat-treating techniques provide hardened, wear-resistant gearing.

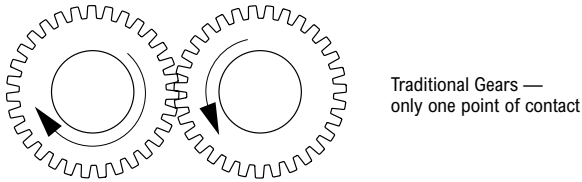
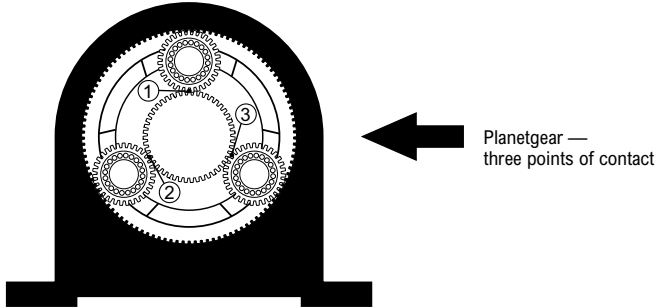

Superior Seal Protection

Many reducer failures are attributed to bearing contamination.

Planetgear reducers are designed with TWO seals on both the input and output shafts. Our successful seal layout can be seen below.

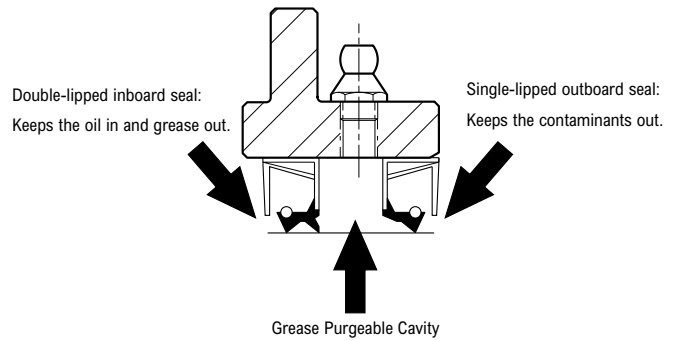

Planetgear reducers assure extended reducer service-life even in the worst environments.

How to Select Gear Drives

Selection of Planetgear

Selection of Planetgear is based on the required output torque capacity of the application. The service factor method illustrated below is used to apply industry application standards based on the hours per day of operation. These application standards (service factors) are cataloged and have been developed based on practical application experience.

Information required to make reducer selection:

- The specific application and hours per day of operation.
- Reducer input speed.
- Input horsepower.
- Desired reducer output speed.
- If applicable, overhung load.

Step 1 — Determine service factor

Select the appropriate service factor from **Table 1** on **pages 8 and 9** for the industry and specific applications at hand. These service factors are designed for applications driven by electric motors.

| Steam & Gas Turbines, Hydraulic or Electric Motors | Single Cylinder Engines | Multi-Cylinder Engines |
|--|-------------------------|------------------------|
| 1.00 | 1.50 | 1.25 |
| 1.25 | 1.75 | 1.50 |
| 1.50 | 2.00 | 1.75 |
| 1.75 | 2.25 | 2.00 |
| 2.00 | 2.50 | 2.25 |

If a single or multiple cylinder engine is used, adjust the service factor that is taken from **Table 1** with the corresponding values listed above.

Rating tables are available for horizontal mounting and input speeds of 1750, 1430, 1170 and 870 rpm.

Step 2 — Calculate the desired reducer ratio (D.R.) using:

$$D.R. = \frac{\text{Input Speed (RPM)}}{\text{Output Speed (RPM)}}$$

Step 3 — Select closest nominal ratio (N.R.)

Reference **pages 11-15**. Pick the ratio that is closest to the desired ratio calculated in Step 2.

Step 4 — Calculate equivalent output torque (E.O.T.) using:

A. When input motor horsepower is known:

NOTE: 59,900 is used to represent the average mechanical efficiency of reducers (59,900 = 63,025 × 95%).

$$E.O.T. = \frac{HP \times N.R. \times S.F. \times 59,900}{RPM_{in}}$$

B. Where required output torque is known:

$$E.O.T. = T_0 \times S.F.$$

where:

HP = Motor horsepower

N.R. = Nominal ratio from Step 3

S.F. = Service factor from Step 1

RPM_{in} = Reducer input shaft speed in revolutions per minute

T₀ = Output torque required in lb-in

Step 5 — Select reducer

Use the nominal ratio determined from Step 3. Locate the smallest series that offers the output torque (lb-in) rating that is equal to or greater than the equivalent output torque (E.O.T.) determined from Step 4 for the nominal ratio required.

Step 6 — Check thermal capacity

The motor horsepower capacity must be compared to the thermal capacity of the reducer. Refer to the thermal horsepower limits tables on **page 16** and select the rating With Fan which corresponds to the reducer series and nominal ratio required. If the nominal ratio is not listed, your application will not be thermally limited with respect to horsepower. If no horsepower is listed under the nominal ratio, your application will not be thermally limited with respect to horsepower.

If a number is listed, it may need to be adjusted based on application details before comparing against the motor rating. Use the following formula for comparison:

$$\text{Motor HP Rating vs. } (T_r)(A_c)$$

where:

T_r = Thermal rating - **page 16**

A_c = Ambient Temperature Adjustment Factor from **page 17**

If the motor horsepower is less than or equal to the rating, your application will not be thermally limited with respect to horsepower with a cooling fan. If your motor horsepower exceeds this rating, contact the factory to review the possibility of increasing the thermal capacity by use of a heat exchanger. Thermal ratings can be ignored if continuous running time does not exceed idle time on a per-hour basis.

Step 7 — Check dimensions

Dimensional drawings for reducers with and without accessories are found on **pages 18-23**.

Step 8 — Ordering reducers

See reducer order form on **page 26**.

How to Select Gear Drives

When Motor Horsepower Is Known:

A 75 hp 1,750 rpm motor in a 365T frame is used to drive a heavy-duty bucket elevator 24 hrs/day with a 6-7/16" head shaft. The application requires a reducer that is hollow shaft-mounted with an output speed of 18 rpm. A motor will be mounted on top of the reducer and driven by a 2.25:1 v-belt drive into the reducer. The pitch diameter of the sheave mounted on the reducer input shaft is 16". The centerline will be positioned at 2.25" from the input shaft seal carrier. In addition, the customer has requested an internal backstop and input shaft belt guard.

Step 1 — Select service factor

From **Table 1** on **pages 8 and 9**, the service factor for a heavy-duty bucket elevator 24 hrs/day operation is 1.5.

Step 2 — Calculate desired ratio (D.R.)

$$\text{Reducer Input Speed} = \frac{\text{Motor RPM}}{\text{Belt Drive Ratio}} = \frac{1750}{2.25} = 778 \text{ RPM input}$$

$$\text{D.R.} = \frac{778 \text{ RPM}}{18 \text{ RPM}} = 43.22$$

Step 3 — Select closest nominal ratio (N.R.)

Reference **pages 10-14**. Select nominal ratio = 43.78

$$\text{Output Speed} = \frac{778 \text{ RPM}}{43.78} = 17.8 \text{ RPM}$$

Step 4 — Calculate equivalent output torque (E.O.T.) hp method

$$\text{E.O.T.} = \frac{75 \text{ HP} \times 43.78 \text{ N.R.} \times 1.5 \text{ S.F.} \times 59,900}{778 \text{ (input RPM)}} = 379,206 \text{ lb-in}$$

Step 5 — Select reducer

Reference **pages 11 and 12**. The Orion rates for 263,205 lb-in and the Titan rates for 471,737 lb-in. The smallest series that meets the E.O.T. calculated in Step 4 is the Titan.

Step 6 — Check thermal capacity

Compare the motor horsepower to the thermal ratings of the reducers with the following formula:

$$\text{Motor HP} \leq (T_r)(A_c)$$

Using the 870 RPM input speed from the thermal rating on **page 16** is 43.78:1 ratio T_r with fan = 144.

$$A_c = 1.0$$

$$75 \text{ (Motor HP)} \leq 144 \text{ (thermal rating)} (1.0)$$

$$75 < 144$$

The motor horsepower is less than the thermal rating.

Step 7 — Check dimensions

Dimensions for the Titan on **pages 18 and 19** for available hollow bore sizes and reducer dimensions, **page 20** for top motor mount detail and **page 21** for belt guard detail.

Step 8 — Order Shaft-Mounted Planetgear reducer

Create the model number using **page 10**. The correct model number is WDVA0043336J41A.

When Required Output Torque Is Known:

A heavy-duty apron conveyor is operating 24 hrs/day. The conveyor requires a reducer with a 3.7 rpm output speed and 1,600,000 lb-in output torque. The reducer will be driven by a 100 hp motor in a 405T frame with a 1750 rpm base speed. The v-belt drive ratio is 2:1 with an 18" diameter sheave on the reducer input shaft 3" from the seal carrier.

Step 1 — Select service factor

From **Table 1** on **pages 8 and 9**, the service factor for a heavy-duty apron conveyor 24 hrs/day operation is 1.50.

Step 2 — Calculate desired ratio (D.R.)

Step 3 — Select closest nominal ratio (N.R.)

Reference **pages 11-15**. Select nominal ratio = 238.2.

Step 4 — Calculate equivalent output torque (E.O.T.)

Since output torque is known:

$$\text{E.O.T.} = 1,600,000 \text{ (output torque in lb-in)} \times 1.5 \text{ (service factor)} = 2,400,000 \text{ lb-in.}$$

Step 5 — Select reducer

Use rating selection on **pages 11-15**. With nominal ratio of 238.2, the smallest series listed for the E.O.T. calculated in Step 4 (2,400,000 lb.-in.) is a Hercules at 2,995,000 lb-in.

Step 6 — Order Shaft-Mounted Planetgear reducer

See reducer order form on **page 26**.

Service Factors

Non-Motorized Selection

Table 1 — Service Factors

| Application | Service | | Application | Service | | Application | Service | | Application | Service | |
|--|------------|------------|---|------------|------------|---------------------------------------|------------|------------|---|------------|------------|
| | 10 Hrs/Day | 24 Hrs/Day | | 10 Hrs/Day | 24 Hrs/Day | | 10 Hrs/Day | 24 Hrs/Day | | 10 Hrs/Day | 24 Hrs/Day |
| AGITATORS | | | COLLECTORS (Sewage) | 1.00 | 1.25 | Light (Small Diameter) | 1.00 | 1.25 | Notching Press (Belted) | - | - |
| Pure Liquids | 1.00 | 1.25 | COMPRESSORS | | | FEEDERS | | | Plate Planers | 1.75 | 2.00 |
| Liquids & Solids | 1.25 | 1.50 | Centrifugal | 1.00 | 1.25 | Apron, Belt | 1.25 | 1.50 | Punch Press (Geared) | 1.75 | 2.00 |
| Liquids-Variable Density | 1.25 | 1.50 | Lobe | 1.25 | 1.50 | Disc | 1.00 | 1.25 | Tapping Machines | 1.75 | 2.00 |
| APRON CONVEYORS | | | Reciprocating | | | Reciprocating | 1.75 | 2.00 | MANGLE (Textile) | 1.25 | 1.50 |
| Uniformly-Loaded or Fed | 1.00 | 1.25 | Multi-Cylinder | 1.50 | 1.75 | Screw | 1.25 | 1.50 | MASH TUBS (Brewing & Distilling) | 1.00 | 1.25 |
| Heavy-Duty | 1.25 | 1.50 | Single-Cylinder | 2.25 | 2.50 | FLIGHT CONVEYORS | | | MEAT GRINDERS (Food) | 1.25 | 1.50 |
| APRON FEEDERS | 1.25 | 1.50 | CONCRETE MIXERS | | | Uniform | 1.00 | 1.25 | METAL MILLS | | |
| ASSEMBLY CONVEYORS | | | Continuous | 1.25 | 1.50 | Heavy | 1.25 | 1.50 | Draw Bench Carriages & Main Drives | 1.25 | 1.50 |
| Uniformly-Loaded or Fed | 1.00 | 1.25 | Intermittent | 1.25 | 1.50 | FOOD INDUSTRY | | | Pinch, Dryer & Scrubber Rolls, | | |
| Heavy-Duty | 1.25 | 1.50 | CONVEYORS — Uniformly-Loaded or Fed | | | Beet Slicers | 1.25 | 1.50 | Reversing | - | - |
| BALL MILLS | ** | ** | Apron, Bucket, Assembly, Belt, Chain, Flight, Oven, Screw | 1.00 | 1.25 | Bottling, Can Filling Machine | 1.00 | 1.25 | Slitters | 1.25 | 1.50 |
| BARGE HAUL PULLERS | 1.75 | 2.00 | CONVEYORS — Heavy-Duty, Not Uniformly Fed | | | Cereal Cookers | 1.00 | 1.25 | Table Conveyors, Non-Reversing | | |
| BARKING | | | Apron, Assembly, Belt, Bucket, Chain, Flight, Oven, Screw | 1.25 | 1.50 | Dough Mixers, Meat Grinders | 1.25 | 1.50 | Group Drives | 1.25 | 1.50 |
| Drums (Coupling-Connected) | - | 2.00 | CONVEYORS — Severe Duty | | | GENERATORS (Not Welding) | 1.00 | 1.25 | Individual | 1.75 | 2.00 |
| Mechanical | - | 2.00 | Live Roll | * | * | GRAVITY DISCHARGE ELEVATORS | 1.00 | 1.25 | Reversing | - | - |
| BAR SCREENS (Sewage) | 1.00 | 1.25 | Reciprocating Shaker | 1.75 | 2.00 | Uniform | 1.00 | 1.25 | Wire Drawing & Flattening Machines | 1.25 | 1.50 |
| BATCHERS (Textile) | 1.25 | 1.50 | COOKERS (Brewing & Distilling), (Food) | 1.00 | 1.25 | HAMMER MILLS | 1.75 | 2.00 | Wire Winding Machines | 1.25 | 1.50 |
| BELT CONVEYORS | | | COOLING TOWER FANS | * | * | HOISTS | | | MILLS, ROTARY | | |
| Uniformly-Loaded or Fed | 1.00 | 1.25 | CRANES | | | Heavy-Duty | 1.75 | 2.00 | Ball and Rod Mills | | |
| Heavy-Duty | 1.25 | 1.50 | Dry Dock Cranes | ♦ | ♦ | Medium Duty | 1.25 | 1.50 | with Spur Ring Gear | - | 2.00 |
| BELT FEEDERS | 1.25 | 1.50 | Main Hoist | * | * | Skip Hoist | 1.25 | 1.50 | with Helical Ring Gear | - | 1.50 |
| BENDING ROLLS (Machine) | 1.25 | 1.50 | Bridge and Trolley Travel | * | * | INDUCED DRAFT FANS | 1.25 | 1.50 | Direct Connected | - | 2.00 |
| BLOWERS | | | CRUSHERS | | | KILNS | ** | ** | Kilns, Dryers & Coolers, Pebble, Plain & Cement Kilns | * | * |
| Centrifugal | 1.00 | 1.25 | Ore or Stone | 1.75 | 2.00 | LAUNDRY WASHERS & TUMBLERS | 1.25 | 1.50 | Wedge Bar Mills | - | 1.50 |
| Lobe | 1.25 | 1.50 | Sugar | - | 1.50 | LINE SHAFTS | | | Tumbling Barrels | 1.75 | 2.00 |
| Vane | 1.00 | 1.25 | DEWATERING SCREENS (Sewage) | 1.25 | 1.50 | Driving Processing Equipment | 1.25 | 1.50 | MIXER (Also see Agitators) | | |
| BOTTLING MACHINERY | 1.00 | 1.25 | DISC FEEDERS | 1.00 | 1.25 | Other Line Shafts, Light | 1.00 | 1.25 | Concrete, Cont. | 1.25 | 1.50 |
| BREWING & DISTILLING | | | DISTILLING (See Brewing) | | | LIVE ROLL CONVEYORS | * | * | Concrete, Int. | 1.25 | 1.50 |
| Bottling Machinery | 1.00 | 1.25 | DOUBLE-ACTING PUMPS | | | LOBE BLOWERS OR COMPRESSORS | 1.25 | 1.50 | Constant Density | 1.00 | 1.25 |
| Brew Kettles, Cont. Duty | 1.00 | 1.25 | 2 or more Cylinders | 1.25 | 1.50 | LOG HAULS (Lumber) | | | Variable Density | 1.25 | 1.50 |
| Can Filling Machines | 1.00 | 1.25 | Single-Cylinder | 1.25 | 1.50 | Incline-Well Type | 1.75 | 1.75 | NAPPERS (Textile) | 1.25 | 1.50 |
| Cookers, Cont. Duty | 1.00 | 1.25 | DOUGH MIXER (Food) | 1.25 | 1.50 | LOOMS (Textile) | 1.25 | 1.50 | OIL INDUSTRY | | |
| Mash Tubs, Cont. Duty | 1.00 | 1.25 | DRAW BENCH (Metal Mills) | 1.25 | 1.50 | LUMBER INDUSTRY | | | Chillers | 1.25 | 1.50 |
| Scale Hoppers, Freq. Starts | 1.25 | 1.50 | Carriage & Main Drive | 1.25 | 1.50 | Barkers — Spindle Feed | 1.25 | 1.50 | Oil Well Pumping | * | * |
| BRICK PRESS (Clay Working) | 1.75 | 2.00 | DREDGES | | | Barkers — Main Drive | 1.75 | 1.75 | Paraffin Filter Press | 1.25 | 1.50 |
| BRIQUETTE MACHINES (Clay Working) | 1.75 | 2.00 | Cable Reels, Conveyors | 1.25 | 1.50 | Carriage Drive | * | * | Rotary Kilns | 1.25 | 1.50 |
| BUCKET | | | Cutter Head & Jig Drives | 1.75 | 2.00 | Chain — Floor | 1.50 | 1.50 | ORE CRUSHERS | 1.75 | 2.00 |
| Conveyors Uniform | 1.00 | 1.25 | Maneuvering Winches, Pumps | 1.25 | 1.50 | Chains — Green | 1.50 | 1.75 | OVEN CONVEYORS | | |
| Conveyors Heavy-Duty | 1.25 | 1.50 | Screen Drives | 1.75 | 2.00 | Conveyors | | | Uniform | 1.00 | 1.25 |
| Elevators Continuous | 1.00 | 1.25 | Stackers, Utility Winches | 1.25 | 1.50 | Burner | 1.25 | 1.50 | Heavy-Duty | 1.25 | 1.50 |
| Elevators Uniform | 1.00 | 1.25 | DRY DOCK CRANES | ♦ | ♦ | Main or Heavy-Duty | 1.50 | 1.50 | PAPER MILLS ● | | |
| Elevators Heavy-Duty | 1.25 | 1.50 | DRYERS & COOLERS (Mills, Rotary) | - | 1.50 | Main Log | 1.75 | 2.00 | Agitator (Mixer) | - | 1.50 |
| CALENDERS | | | DYEING MACHINERY (Textile) | 1.25 | 1.50 | Re-Saw Merry-Go-Round | 1.25 | 1.50 | Agitator for Pure Liquors | - | 1.25 |
| Rubber | 1.50 | 1.50 | ELEVATORS | | | Slab | 1.75 | 2.00 | Barking Drums, Barkers | | |
| Textile | 1.25 | 1.50 | Bucket-Uniform-Load | 1.00 | 1.25 | Transfer | 1.25 | 1.50 | Mechanical | - | 2.00 |
| CAN FILLING MACHINES | 1.00 | 1.25 | Bucket-Heavy-Duty | 1.25 | 1.50 | Cut-Off Saws — Chain & Drag | 1.50 | 1.75 | Beater | - | 1.50 |
| CANE KNIVES | 1.50 | 1.50 | Bucket-Continuous | 1.00 | 1.25 | Debarking Drums | 1.75 | 2.00 | Breaker Stack | - | 1.25 |
| CARD MACHINES (Textile) | 1.25 | 1.50 | Centrifugal Discharge | 1.00 | 1.25 | Feeds — Edger | 1.25 | 1.50 | Calender ■ | - | 1.25 |
| CAR DUMPERS | 1.75 | 2.00 | Escalators | * | * | Feeds — Gang | 1.75 | 1.75 | Chipper | - | 2.00 |
| CAR PULLERS | 1.25 | 1.50 | Freight | 1.00 | 1.25 | Feeds — Trimmer | 1.25 | 1.50 | Chip Feeder | - | 1.50 |
| CEMENT KILNS | ** | ** | Gravity Discharge | 1.00 | 1.25 | Log Deck | 2.00 | 2.00 | Coating Rolls | - | 1.25 |
| CENTRIFUGAL | | | Man Lifts, Passenger | * | * | Log Hauls — Incline-Well Type | 1.75 | 1.75 | Conveyors — | | |
| Blowers, Compressors, Discharge Elevators, Fans or Pumps | 1.00 | 1.25 | EXTRUDERS | ‡ | ‡ | Log Turning Devices | 1.75 | 1.75 | Chip, Bark, Chemical | - | 1.25 |
| CHAIN CONVEYORS | | | FANS | | | Planer Feed | 1.25 | 1.50 | Log (including Slab) | - | 2.00 |
| Uniformly-Loaded or Fed | 1.00 | 1.25 | Centrifugal | 1.00 | 1.25 | Planer Tilting Hoists | 1.50 | 1.50 | Couch Rolls | - | 1.25 |
| Heavy-Duty | 1.25 | 1.50 | Cooling Towers | * | * | Rolls, Live Off Bearing | | | Cutter | - | 2.00 |
| CHEMICAL FEEDERS (Sewage) | 1.00 | 1.25 | Forced Draft | - | 1.25 | Roll Cases | 1.75 | 1.75 | Cylinder Molds | - | 1.25 |
| CLARIFIERS | 1.00 | 1.25 | Induced Draft | 1.25 | 1.50 | Sorting, Table, Tipple Hoist | 1.25 | 1.50 | Dryers — ■ | | |
| CLASSIFIERS | 1.25 | 1.50 | Large (Mine, etc.) | 1.25 | 1.50 | Transfers — Chain & Craneway | 1.50 | 1.75 | Paper Machine & Conveyor Type | - | 1.25 |
| CLAY WORKING INDUSTRY | | | Large Industrial | 1.25 | 1.50 | Tray Devices | 1.25 | 1.50 | Embossor | - | 1.25 |
| Brick Press | 1.75 | 2.00 | COLLECTORS (Sewage) | 1.00 | 1.25 | Veneer Lathe Drives | * | * | Extruder | - | 1.50 |
| Briquette Machines | 1.75 | 2.00 | COMPRESSORS | | | MACHINE TOOLS | | | Foundriner Rolls | | |
| Clay Working Machinery | 1.25 | 1.50 | Centrifugal | 1.00 | 1.25 | Auxiliary Drives | 1.00 | 1.25 | Lumberbreaker, Wire Turning, Dandy & Return Rolls | - | 1.25 |
| Pug Mills | 1.25 | 1.50 | Lobe | 1.25 | 1.50 | Bending Rolls | 1.25 | 1.50 | Jordan | - | 1.50 |

- ♦ Dry Dock Cranes (Hammerhead, Rotating and Whirler, Stationary or Moving) for any duration of service: Main Hoist, Auxiliary Hoist, Boom (Lifting): 3.00 S.F.; Rotating (Swing or Slew): 3.00 S.F.; Tracking (Drive Wheels): 3.00 S.F.
- Service factors for paper mill application are applied to nameplate rating of electric motor at the motor-rated base speed — consistent with TAPPI Standards.
- ▲ When a super calender operates over a speed range of part constant HP and torque and the constant HP speed range is greater than 1.5:1, use a service factor of 1.0 at base speed. When operating at constant torque over the entire speed range or when the constant HP speed range is less than 1.5:1, a 1.25 factor should be applied.
- * Consult Factory.
- ** See Mills, Rotary.
- Using anti-friction bearings only.
- ‡ See Rubber & Plastics Industries.

Service Factors

Non-Motorized Selection

Table 1 — Service Factors (Continued)

| Application | Service | | Application | Service | |
|---|------------|------------|-----------------------------------|------------|------------|
| | 10 Hrs/Day | 24 Hrs/Day | | 10 Hrs/Day | 24 Hrs/Day |
| Kiln Drive | — | 1.50 | Collectors | 1.00 | 1.25 |
| Mt. Hope & Paper Rolls | — | 1.25 | Dewatering Screens | 1.25 | 1.50 |
| Platter | — | 1.50 | Scum Breakers | 1.25 | 1.50 |
| Presses (Felt & Suction) | — | 1.25 | Slow or Rapid Mixers | 1.25 | 1.50 |
| Pulper — Continuous | — | 1.50 | Thickeners | 1.25 | 1.50 |
| Repulper — Heavy Stock | — | 2.00 | Vacuum Filters | 1.25 | 1.50 |
| Vacuum Pumps | — | 1.50 | SHAKER CONVEYORS | 1.75 | 2.00 |
| Reel (Surface Type) | — | 1.25 | SINGLE-ACTING PUMP | | |
| Screens — | | | 1 or 2 Cylinders | * | * |
| Chip, Rotary | — | 1.50 | 3 or more Cylinders | 1.25 | 1.50 |
| Vibrating | — | 2.00 | SKIP HOIST | 1.25 | 1.50 |
| Size Press | — | 1.25 | SLAB PUSHERS | 1.25 | 1.50 |
| Super Calender ▲ | — | 1.25 | SLITTERS (Metal) | 1.25 | 1.50 |
| Thickener & Washer — | | | SLUDGE COLLECTORS (Sewage) | 1.00 | 1.25 |
| AC Motor | — | 1.50 | SOAPERS (Textile) | 1.25 | 1.50 |
| DC Motor | — | 1.25 | SPINNERS (Textile) | 1.25 | 1.50 |
| Wind & Unwind Stand | — | 1.00 | STEERING GEARS | * | * |
| Winders (Surface Type) | — | 1.25 | STOKERS | 1.00 | 1.25 |
| Yankee Dryers | — | 1.25 | STONE CRUSHERS | 1.75 | 2.00 |
| PASSENGER ELEVATORS | * | * | SUGAR INDUSTRY | | |
| PEBBLE MILLS | — | 1.50 | Cane, Knives, Crushers | 1.50 | 1.50 |
| PLASTIC INDUSTRY ‡ | ‡ | ‡ | Mills (Low-Speed End) | 2.00 | 2.00 |
| PLATE PLANERS | 1.75 | 2.00 | TABLE CONVEYORS | | |
| PRINTING PRESSES | * | * | (Non-Reversing) | | |
| PROPORTIONING PUMPS | 1.25 | 1.50 | Group Drives | 1.25 | 1.50 |
| PUG MILLS (Clay) | 1.25 | 1.50 | Individual Drives | 1.75 | 2.00 |
| PULLERS (Barge Haul) | 1.75 | 2.00 | Reversing | * | * |
| PUMPS | | | TENTER FRAMES (Textile) | 1.25 | 1.50 |
| Centrifugal | 1.00 | 1.25 | TEXTILE INDUSTRY | | |
| Proportioning | 1.25 | 1.50 | Batchers, Calenders | 1.25 | 1.50 |
| Reciprocating | | | Card Machines | 1.25 | 1.50 |
| Single-Act., 3 or more Cyl. | 1.25 | 1.50 | Dry Cans, Dryers | 1.25 | 1.50 |
| Double-Act., 2 or more Cyl. | 1.25 | 1.50 | Dyeing Machinery | 1.25 | 1.50 |
| Single-Act., 1 or 2 Cyl. | * | * | Knitting Machinery | * | * |
| Double-Acting, 1 Cyl. | * | * | Looms, Mangles, Nappers, Pads | 1.25 | 1.50 |
| Rotary: Gear, Lobe, Vane | 1.00 | 1.25 | Range Drives | * | * |
| PUNCH PRESSES | | | Slashers, Soapers, Spinners | 1.25 | 1.50 |
| (Gear-Driven) | 1.75 | 2.00 | Tenter Frames, Washers, Winders | 1.25 | 1.50 |
| RECIPROCATING | | | THICKENERS (Sewage) | 1.25 | 1.50 |
| Conveyors & Feeders | 1.75 | 2.00 | TUMBLING BARRELS | 1.75 | 2.00 |
| RECIPROCATING COMPRESSORS | | | VACUUM FILTERS (Sewage) | 1.25 | 1.50 |
| Multi-Cylinder | 1.25 | 1.50 | VANE BLOWERS | 1.00 | 1.25 |
| Single-Cylinder | 1.50 | 2.50 | WINCHES (Dredges) | 1.25 | 1.50 |
| ROD MILLS | ** | ** | WINDERS (Textile) | 1.25 | 1.50 |
| ROTARY | | | WINDLASS | * | * |
| Pumps | 1.00 | 1.25 | WIRE | | |
| Screens (Sand or Gravel) | 1.25 | 1.50 | Drawing Machines | 1.25 | 1.50 |
| RUBBER & PLASTICS INDUSTRIES | | | Winding Machines | 1.25 | 1.50 |
| Calenders | 1.50 | 1.50 | | | |
| Crackers | 2.00 | 2.00 | | | |
| Mills (2 on-line) | 1.50 | 1.50 | | | |
| Mills (3 on-line) | 1.25 | 1.25 | | | |
| Mixing Mills | 1.50 | 1.50 | | | |
| Refiners & Sheeters | 1.50 | 1.50 | | | |
| SAND MULLERS | 1.25 | 1.50 | | | |
| SCREENS | | | | | |
| Air Washing | 1.00 | 1.25 | | | |
| Rotary — Sand or Gravel | 1.25 | 1.50 | | | |
| Traveling Water Intake | 1.00 | 1.25 | | | |
| SCREW CONVEYORS | | | | | |
| Uniform | 1.00 | 1.25 | | | |
| Heavy-Duty or Feeder | 1.25 | 1.50 | | | |
| SCUM BREAKERS (Sewage) | 1.25 | 1.50 | | | |
| SEWAGE DISPOSAL | | | | | |
| Bar Screens | 1.00 | 1.25 | | | |
| Chemical Feeders | 1.00 | 1.25 | | | |

- ◆ Dry Dock Cranes (Hammerhead, Rotating and Whirler, Stationary or Moving) for any duration of service: Main Hoist, Auxiliary Hoist, Boom (Lifting): 3.00 S.F.; Rotating (Swing or Slew): 3.00 S.F.; Tracking (Drive Wheels): 3.00 S.F.
- Service factors for paper mill application are applied to nameplate rating of electric motor at the motor-rated base speed — consistent with TAPPI Standards.
- ▲ When a super calender operates over a speed range of part constant HP and torque and the constant HP speed range is greater than 1.5:1, use a service factor of 1.0 at base speed. When operating at constant torque over the entire speed range or when the constant HP speed range is less than 1.5:1, a 1.25 factor should be applied.
- * Consult Factory.
- ** See Mills, Rotary.
- Using anti-friction bearings only.
- ‡ See Rubber & Plastics Industries.

Nomenclature

Table 2 — Part Number Schema and Processes for User Configurable Units

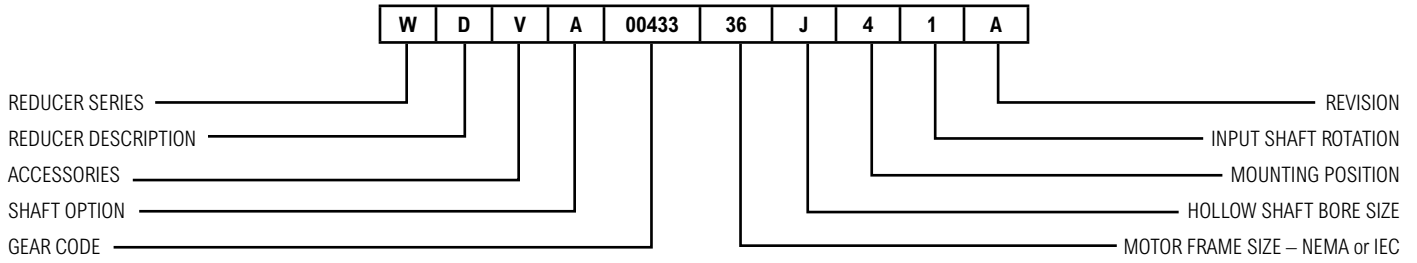

Reducer Series

- W Orion
- T Titan
- J Jupiter
- G Gemini
- H Hercules

Reducer Description

- A Standard
- B Backstop
- C Non-Horizontal
- D Non-Horizontal w/Backstop
- E Integral
- F Non-Horizontal Integral

Accessories

- A No Accessories
- B Scoop Mount with Omega Coupling
- E Motor Mount
- K Special
- P Scoop Mount without High-Speed Coupling
- V Motor Mount with Belt Guard

Shaft Option

- A Input/Output Standard
- B Input/Output Standard w/Fan & Shroud
- C Input Modified
- D Input Modified w/Fan & Shroud
- E Output Modified
- F Output Modified w/Fan & Shroud
- G Input/Output Modified
- H Input/Output Modified w/Fan & Shroud
- S Heavy-Duty Input
- T Heavy-Duty Input w/Fan & Shroud

Gear Code

- 000XX Double
- 00XXX Triple
- 0XXXX Quad
- XXXXX Quint

Motor Frame Size - NEMA

- 00 None
- 05 56
- 14 143/145T
- 18 182/184T
- 21 213/215T
- 25 254/256T
- 28 284/286T
- 32 324/326T
- 36 364/365T
- 40 404/405T
- 44 444/445T
- 47 447/449T
- ZZ Special

Motor Frame Size - IEC

- 00 None
- 80 80
- 90 90S&L
- 11 112M
- 13 132S&L
- 16 160M&L
- 17 180M&L
- 20 200L
- 22 225S
- 23 225L

Hollow Shaft Bore Size

- F 5.313"
- G 5.437"
- H 5.708"
- I 6.299"
- J 6.436"
- K 6.692"
- L 7.480"
- M 7.874"
- N 9.843"
- O 11.811"
- Z Special

Mounting Position

- 1 B3
- 2 B6
- 3 B7
- 4 B8
- 5 V5
- 6 V6
- Z Special

Input Shaft Rotation

- 1 Clockwise
- 2 Counterclockwise
- X No Backstop

Revision

- A

Orion Ratings

Orion Ratings Table

| Nominal Ratio | Orion | | 1750 | | | 1450 | | | 1170 | | | 870 | | |
|---------------|-------------|-----------|---------|------|----------|---------|------|----------|---------|------|----------|---------|------|----------|
| | Exact Ratio | Gear Code | RPM Out | HP | Torque ▲ | RPM Out | HP | Torque ▲ | RPM Out | HP | Torque ▲ | RPM Out | HP | Torque ▲ |
| 11.02 | 11.02 | 00033 | 158.8 | 371 | 140 | 131.6 | 325 | 148 | 106.2 | 280 | 158 | 79.0 | 227 | 172 |
| 13.85 | 13.66 | 00043 | 128.1 | 310 | 145 | 106.2 | 273 | 154 | 85.7 | 235 | 164 | 63.7 | 190 | 179 |
| 17.21 | ... | ... | ... | ... | ... | ... | ... | ... | ... | ... | ... | ... | ... | ... |
| 20.41 | 19.05 | 00063 | 91.9 | 236 | 154 | 76.1 | 207 | 163 | 61.4 | 178 | 174 | 45.7 | 145 | 190 |
| 24.00 | ... | ... | ... | ... | ... | ... | ... | ... | ... | ... | ... | ... | ... | ... |
| 31.63 | 31.37 | 00323 | 55.8 | 152 | 159 | 46.2 | 133 | 168 | 37.3 | 114 | 179 | 27.7 | 93.1 | 196 |
| 36.56 | 36.57 | 00333 | 47.9 | 164 | 200 | 39.7 | 144 | 212 | 32.0 | 124 | 226 | 23.8 | 101 | 247 |
| 43.78 | 45.33 | 00433 | 38.6 | 141 | 214 | 32.0 | 124 | 226 | 25.8 | 106 | 241 | 19.2 | 86.7 | 264 |
| 54.45 | 56.18 | 00443 | 31.1 | 118 | 222 | 25.8 | 103 | 234 | 20.8 | 89.1 | 250 | 15.5 | 67.3 | 254 |
| 64.42 | 63.23 | 00633 | 27.7 | 112 | 236 | 22.9 | 98.1 | 250 | 18.5 | 84.3 | 266 | 13.8 | 64.1 | 272 |
| 69.63 | 68.20 | 00373 | 25.7 | 90.1 | 205 | 21.3 | 75.0 | 206 | 17.2 | 61.1 | 208 | 12.8 | 45.9 | 210 |
| 80.01 | 78.37 | 00643 | 22.3 | 93.7 | 245 | 18.5 | 80.4 | 254 | 14.9 | 64.9 | 254 | 11.1 | 48.5 | 255 |
| 91.41 | 84.54 | 00473 | 20.7 | 73.4 | 207 | 17.2 | 61.1 | 208 | 13.8 | 49.8 | 210 | 10.3 | 37.3 | 212 |
| 99.38 | 104.12 | 03323 | 16.8 | 49.9 | 169 | 13.9 | 43.8 | 179 | 11.2 | 37.7 | 191 | 8.4 | 30.7 | 209 |
| 111.5 | 109.32 | 00663 | 16.0 | 58.4 | 213 | 13.3 | 48.6 | 214 | 10.7 | 39.2 | 214 | 8.0 | 29.3 | 215 |
| 121.4 | 121.37 | 03333 | 14.4 | 49.9 | 197 | 11.9 | 43.6 | 208 | 9.6 | 37.6 | 222 | 7.2 | 30.7 | 244 |
| 138.5 | 129.06 | 03423 | 13.6 | 49.8 | 209 | 11.2 | 43.8 | 222 | 9.1 | 37.6 | 236 | 6.7 | 30.7 | 259 |
| 159.8 | 150.44 | 03433 | 11.6 | 49.8 | 244 | 9.6 | 43.7 | 258 | 7.8 | 37.6 | 275 | 5.8 | 27.8 | 274 |
| 174.8 | 180.03 | 03623 | 9.7 | 45.4 | 266 | 8.1 | 39.5 | 279 | 6.5 | 31.8 | 279 | 4.8 | 23.8 | 280 |
| 193.1 | 186.48 | 04433 | 9.4 | 41.7 | 253 | 7.8 | 37.4 | 274 | 6.3 | 30.2 | 274 | 4.7 | 22.5 | 275 |
| 206.2 | 209.86 | 03633 | 8.3 | 40.1 | 274 | 6.9 | 32.5 | 268 | 5.6 | 26.8 | 274 | 4.1 | 20.0 | 275 |
| 238.2 | 223.16 | 04623 | 7.8 | 38.4 | 279 | 6.5 | 31.8 | 279 | 5.2 | 25.8 | 280 | 3.9 | 19.2 | 280 |
| 265.4 | 260.13 | 04633 | 6.7 | 32.4 | 274 | 5.6 | 26.8 | 274 | 4.5 | 21.7 | 275 | 3.3 | 16.1 | 275 |
| 295.7 | 311.30 | 06623 | 5.6 | 27.5 | 279 | 4.7 | 22.9 | 280 | 3.8 | 18.5 | 280 | 2.8 | 13.7 | 280 |
| 330.1 | 345.59 | 04643 | 5.1 | 22.8 | 257 | 4.2 | 18.9 | 257 | 3.4 | 15.3 | 257 | 2.5 | 11.4 | 258 |
| 369.8 | 362.87 | 06633 | 4.8 | 23.3 | 275 | 4.0 | 19.3 | 275 | 3.2 | 15.6 | 275 | 2.4 | 11.6 | 275 |
| 412.1 | 402.84 | 33333 | 4.3 | 21.5 | 275 | 3.6 | 17.8 | 275 | 2.9 | 14.4 | 275 | 2.2 | 10.7 | 275 |
| 459.0 | 449.79 | 06643 | 3.9 | 17.6 | 257 | 3.2 | 14.5 | 257 | 2.6 | 11.8 | 258 | 1.9 | 8.8 | 258 |
| 532.5 | 531.01 | 44323 | 3.3 | 16.3 | 275 | 2.7 | 13.8 | 280 | 2.2 | 11.1 | 280 | 1.6 | 8.3 | 280 |
| 617.9 | 618.97 | 44333 | 2.8 | 14.0 | 275 | 2.3 | 11.6 | 275 | 1.9 | 9.4 | 275 | 1.4 | 7.0 | 276 |
| 660.6 | 696.55 | 63333 | 2.5 | 12.4 | 275 | 2.1 | 10.3 | 275 | 1.7 | 8.3 | 276 | 1.2 | 6.2 | 276 |
| 741.2 | 767.25 | 44433 | 2.3 | 11.3 | 275 | 1.9 | 9.4 | 275 | 1.5 | 7.6 | 276 | 1.1 | 5.6 | 276 |
| 900.3 | 863.42 | 64333 | 2.0 | 10.0 | 275 | 1.7 | 8.3 | 276 | 1.4 | 6.7 | 276 | 1.0 | 5.0 | 276 |
| 1057 | 1070.26 | 64433 | 1.6 | 8.1 | 276 | 1.4 | 6.7 | 276 | 1.1 | 5.4 | 276 | 0.8 | 4.0 | 276 |
| 1255 | 1204.40 | 66333 | 1.5 | 7.2 | 276 | 1.2 | 6.0 | 276 | 1.0 | 4.8 | 276 | 0.7 | 3.6 | 276 |
| 1450 | 1492.93 | 66433 | 1.2 | 5.8 | 276 | 1.0 | 4.8 | 276 | 0.8 | 3.9 | 276 | 0.6 | 2.9 | 276 |
| 1785 | 1786.58 | 66623 | 1.0 | 4.9 | 280 | 0.8 | 4.1 | 280 | 0.7 | 3.3 | 280 | 0.5 | 2.5 | 280 |

▲ Torque shown in 1,000 lb-in.

Titan Ratings

Titan Ratings Table

| Nominal Ratio | Titan | | 1750 | | | 1450 | | | 1170 | | | 870 | | |
|---------------|-------------|-----------|---------|------|----------|---------|------|----------|---------|------|----------|---------|------|----------|
| | Exact Ratio | Gear Code | RPM Out | HP | Torque ▲ | RPM Out | HP | Torque ▲ | RPM Out | HP | Torque ▲ | RPM Out | HP | Torque ▲ |
| 11.02 | 11.02 | 00033 | 158.8 | 665 | 251 | 131.6 | 582 | 265 | 106.2 | 502 | 283 | 79.0 | 407 | 309 |
| 13.85 | 13.66 | 00043 | 128.1 | 556 | 260 | 106.2 | 487 | 275 | 85.7 | 409 | 286 | 63.7 | 341 | 321 |
| 17.21 | ... | ... | ... | ... | ... | ... | ... | ... | ... | ... | ... | ... | ... | ... |
| 20.41 | 19.05 | 00063 | 91.9 | 422 | 275 | 76.1 | 370 | 291 | 61.4 | 319 | 311 | 45.7 | 258 | 339 |
| 24.00 | 24.60 | 00083 | 71.1 | 346 | 291 | 58.9 | 302 | 307 | 47.6 | 260 | 328 | 35.4 | 212 | 359 |
| 31.63 | 31.37 | 00233 | 55.8 | 328 | 343 | 46.2 | 280 | 363 | 37.3 | 247 | 387 | 27.7 | 201 | 423 |
| 36.56 | 36.57 | 00333 | 47.9 | 294 | 359 | 39.7 | 258 | 380 | 32.0 | 222 | 405 | 23.8 | 180 | 443 |
| 43.78 | 45.33 | 00433 | 38.6 | 253 | 383 | 32.0 | 222 | 405 | 25.8 | 191 | 432 | 19.2 | 155 | 472 |
| 54.45 | 56.18 | 00443 | 31.1 | 212 | 398 | 25.8 | 186 | 420 | 20.8 | 160 | 449 | 15.5 | 126 | 477 |
| 64.42 | 63.23 | 00633 | 27.7 | 200 | 423 | 22.9 | 176 | 448 | 18.5 | 151 | 477 | 13.8 | 113 | 478 |
| 69.63 | ... | ... | ... | ... | ... | ... | ... | ... | ... | ... | ... | ... | ... | ... |
| 80.01 | 78.37 | 00643 | 22.3 | 168 | 440 | 18.5 | 148 | 466 | 14.9 | 122 | 477 | 11.1 | 90.8 | 478 |
| 91.41 | ... | ... | ... | ... | ... | ... | ... | ... | ... | ... | ... | ... | ... | ... |
| 99.38 | 104.12 | 03233 | 16.8 | 141 | 477 | 13.9 | 117 | 478 | 11.2 | 94.3 | 478 | 8.4 | 70.3 | 479 |
| 111.5 | 109.32 | 00663 | 16.0 | 124 | 454 | 13.3 | 109 | 478 | 10.7 | 87.6 | 478 | 8.0 | 65.3 | 479 |
| 121.4 | 121.37 | 03333 | 14.4 | 121 | 478 | 11.9 | 100 | 478 | 9.6 | 80.9 | 478 | 7.2 | 60.3 | 479 |
| 138.5 | 129.06 | 04233 | 13.6 | 114 | 478 | 11.2 | 94.3 | 478 | 9.1 | 76.1 | 478 | 6.7 | 56.7 | 479 |
| 159.8 | 150.44 | 04333 | 11.6 | 97.6 | 478 | 9.6 | 80.9 | 478 | 7.8 | 65.4 | 479 | 5.8 | 48.6 | 479 |
| 174.8 | 180.03 | 06233 | 9.7 | 81.6 | 478 | 8.1 | 67.7 | 479 | 6.5 | 54.7 | 479 | 4.8 | 40.6 | 479 |
| 193.1 | 186.48 | 04433 | 9.4 | 78.8 | 478 | 7.8 | 65.4 | 479 | 6.3 | 52.8 | 479 | 4.7 | 39.2 | 479 |
| 206.2 | 209.86 | 06333 | 8.3 | 70.1 | 479 | 6.9 | 58.1 | 479 | 5.6 | 46.9 | 479 | 4.1 | 34.9 | 479 |
| 238.2 | 231.16 | 04443 | 7.6 | 63.7 | 479 | 6.3 | 52.8 | 479 | 5.1 | 42.6 | 479 | 3.8 | 31.7 | 479 |
| 265.4 | 260.13 | 06433 | 6.7 | 56.6 | 479 | 5.6 | 46.9 | 479 | 4.5 | 37.8 | 479 | 3.3 | 28.1 | 479 |
| 295.7 | 280.59 | 04733 | 6.2 | 52.5 | 479 | 5.2 | 43.5 | 479 | 4.2 | 35.1 | 479 | 3.1 | 26.1 | 479 |
| 330.1 | 322.45 | 06443 | 5.4 | 45.6 | 479 | 4.5 | 37.8 | 479 | 3.6 | 30.5 | 479 | 2.7 | 22.7 | 479 |
| 369.8 | 362.87 | 06633 | 4.8 | 40.6 | 479 | 4.0 | 33.6 | 479 | 3.2 | 27.1 | 479 | 2.4 | 20.2 | 480 |
| 412.1 | 391.40 | 06733 | 4.5 | 37.6 | 479 | 3.7 | 31.2 | 479 | 3.0 | 25.1 | 479 | 2.2 | 18.7 | 480 |
| 459.0 | 449.79 | 06643 | 3.9 | 32.7 | 479 | 3.2 | 27.1 | 479 | 2.6 | 21.9 | 479 | 1.9 | 16.3 | 480 |
| 532.5 | 531.01 | 44233 | 3.3 | 28.4 | 479 | 2.7 | 23.6 | 479 | 2.2 | 19.0 | 480 | 1.6 | 14.2 | 480 |
| 617.9 | 627.43 | 06663 | 2.8 | 23.5 | 479 | 2.3 | 19.5 | 480 | 1.9 | 15.7 | 480 | 1.4 | 11.7 | 480 |
| 660.6 | 676.77 | 06763 | 2.6 | 21.7 | 479 | 2.1 | 18.1 | 480 | 1.7 | 14.6 | 480 | 1.3 | 10.8 | 480 |
| 741.2 | 767.25 | 44433 | 2.3 | 19.2 | 480 | 1.9 | 16.3 | 480 | 1.5 | 13.2 | 480 | 1.1 | 9.8 | 480 |
| 900.3 | 863.42 | 64333 | 2.0 | 17.5 | 480 | 1.7 | 14.5 | 480 | 1.4 | 11.7 | 480 | 1.0 | 8.7 | 480 |
| 1057 | 1070.26 | 64433 | 1.6 | 14.1 | 480 | 1.4 | 11.7 | 480 | 1.1 | 9.4 | 480 | 0.8 | 7.0 | 480 |
| 1255 | 1204.40 | 66333 | 1.5 | 12.6 | 480 | 1.2 | 10.4 | 480 | 1.0 | 8.4 | 480 | 0.7 | 6.2 | 480 |
| 1450 | 1492.93 | 66433 | 1.2 | 10.1 | 480 | 1.0 | 8.4 | 480 | 0.8 | 6.8 | 480 | 0.6 | 5.0 | 480 |
| 1785 | 1850.58 | 66443 | 0.9 | 8.2 | 480 | 0.8 | 6.8 | 480 | 0.6 | 5.5 | 480 | 0.5 | 4.1 | 480 |

▲ Torque shown in 1,000 lb-in.

Jupiter Ratings

Jupiter Ratings Table

| Nominal Ratio | Jupiter | | 1750 | | | 1450 | | | 1170 | | | 870 | | |
|---------------|-------------|-----------|---------|------|----------|---------|------|----------|---------|------|----------|---------|-------|----------|
| | Exact Ratio | Gear Code | RPM Out | HP | Torque ▲ | RPM Out | HP | Torque ▲ | RPM Out | HP | Torque ▲ | RPM Out | HP | Torque ▲ |
| 11.02 | ... | ... | ... | ... | ... | ... | ... | ... | ... | ... | ... | ... | ... | ... |
| 13.85 | 12.80 | 00034 | 136.7 | 1088 | 477 | 113.3 | 953 | 504 | 91.4 | 821 | 538 | 68.0 | 667 | 588 |
| 17.21 | 15.87 | 00044 | 110.3 | 898 | 488 | 91.4 | 788 | 517 | 73.7 | 678 | 551 | 54.8 | 551 | 602 |
| 20.41 | 22.14 | 00064 | 79.1 | 683 | 518 | 65.5 | 599 | 548 | 52.9 | 515 | 584 | 39.3 | 419 | 638 |
| 24.00 | ... | ... | ... | ... | ... | ... | ... | ... | ... | ... | ... | ... | ... | ... |
| 31.63 | ... | ... | ... | ... | ... | ... | ... | ... | ... | ... | ... | ... | ... | ... |
| 36.56 | ... | ... | ... | ... | ... | ... | ... | ... | ... | ... | ... | ... | ... | ... |
| 43.78 | 42.49 | 00334 | 41.2 | 482 | 683 | 34.1 | 422 | 722 | 27.5 | 363 | 771 | 20.5 | 289 | 824 |
| 54.45 | 52.67 | 00344 | 33.2 | 398 | 700 | 27.5 | 349 | 741 | 22.2 | 300 | 789 | 16.5 | 233 | 825 |
| 64.42 | 60.92 | 00354 | 28.7 | 355 | 722 | 23.8 | 311 | 764 | 19.2 | 268 | 816 | 14.3 | 202 | 826 |
| 69.63 | 65.29 | 00444 | 26.8 | 343 | 747 | 22.2 | 300 | 789 | 17.9 | 253 | 825 | 13.3 | 188 | 826 |
| 80.01 | 75.52 | 00454 | 23.2 | 306 | 772 | 19.2 | 268 | 816 | 15.5 | 219 | 826 | 11.5 | 163 | 827 |
| 91.41 | 91.08 | 00644 | 19.2 | 271 | 825 | 15.9 | 225 | 825 | 12.8 | 182 | 826 | 9.55 | 135 | 827 |
| 99.38 | ... | ... | ... | ... | ... | ... | ... | ... | ... | ... | ... | ... | ... | ... |
| 111.5 | 105.34 | 00654 | 16.6 | 235 | 825 | 13.8 | 195 | 826 | 11.1 | 157 | 827 | 8.26 | 117.1 | 828 |
| 121.4 | 127.05 | 00664 | 13.8 | 195 | 826 | 11.4 | 162 | 827 | 9.21 | 130 | 827 | 6.85 | 97.1 | 828 |
| 138.5 | 136.04 | 00854 | 12.9 | 182 | 826 | 10.7 | 151 | 827 | 8.60 | 122 | 827 | 6.40 | 90.6 | 828 |
| 159.8 | 149.98 | 02434 | 11.7 | 169 | 827 | 9.67 | 140 | 827 | 7.80 | 113 | 828 | 5.80 | 84.3 | 828 |
| 174.8 | 174.83 | 04334 | 10.0 | 145 | 827 | 8.29 | 121 | 828 | 6.69 | 97.3 | 828 | 4.98 | 72.4 | 829 |
| 193.1 | 202.21 | 03354 | 8.7 | 126 | 827 | 7.17 | 104 | 828 | 5.79 | 84.1 | 828 | 4.30 | 62.6 | 829 |
| 206.2 | 216.71 | 04434 | 8.1 | 117 | 828 | 6.69 | 97.3 | 828 | 5.40 | 78.6 | 829 | 4.01 | 58.4 | 829 |
| 238.2 | 260.13 | 06334 | 6.7 | 97.8 | 828 | 5.57 | 81.0 | 828 | 4.50 | 65.5 | 829 | 3.34 | 48.7 | 829 |
| 265.4 | 268.63 | 04444 | 6.5 | 94.7 | 828 | 5.40 | 78.6 | 829 | 4.36 | 63.4 | 829 | 3.24 | 47.1 | 829 |
| 295.7 | 302.30 | 06434 | 5.8 | 84.2 | 828 | 4.80 | 69.8 | 829 | 3.87 | 56.3 | 829 | 2.88 | 41.9 | 829 |
| 330.1 | 326.07 | 07434 | 5.4 | 78.1 | 829 | 4.45 | 64.7 | 829 | 3.59 | 52.2 | 829 | 2.67 | 38.8 | 829 |
| 369.8 | 374.71 | 06444 | 4.7 | 68.0 | 829 | 3.87 | 56.3 | 829 | 3.12 | 45.4 | 829 | 2.32 | 33.8 | 829 |
| 412.1 | 404.18 | 07444 | 4.3 | 63.0 | 829 | 3.59 | 52.2 | 829 | 2.89 | 42.1 | 829 | 2.15 | 31.3 | 829 |
| 459.0 | 454.84 | 07634 | 3.8 | 56.0 | 829 | 3.19 | 46.4 | 829 | 2.57 | 37.4 | 829 | 1.91 | 27.8 | 829 |
| 532.5 | 522.70 | 06644 | 3.3 | 48.7 | 829 | 2.77 | 40.4 | 829 | 2.24 | 32.6 | 829 | 1.66 | 24.2 | 829 |
| 617.9 | 580.28 | 43334 | 3.0 | 45.0 | 829 | 2.50 | 37.3 | 829 | 2.02 | 30.1 | 829 | 1.50 | 22.4 | 830 |
| 660.6 | 652.10 | 07654 | 2.7 | 39.1 | 829 | 2.22 | 32.4 | 829 | 1.79 | 26.1 | 829 | 1.33 | 19.4 | 830 |
| 741.2 | 729.13 | 06664 | 2.4 | 34.9 | 829 | 1.99 | 28.9 | 829 | 1.60 | 23.4 | 829 | 1.19 | 17.4 | 830 |
| 900.3 | 891.61 | 44434 | 2.0 | 29.3 | 829 | 1.63 | 24.3 | 829 | 1.31 | 19.6 | 830 | 0.98 | 14.6 | 830 |
| 1057 | 1031.25 | 44354 | 1.7 | 25.3 | 829 | 1.41 | 21.0 | 830 | 1.13 | 17.0 | 830 | 0.84 | 12.6 | 830 |
| 1255 | 1243.73 | 64434 | 1.4 | 21.0 | 830 | 1.17 | 17.4 | 830 | 0.94 | 14.1 | 830 | 0.70 | 10.5 | 830 |
| 1450 | 1438.51 | 64354 | 1.2 | 18.2 | 830 | 1.01 | 15.1 | 830 | 0.81 | 12.2 | 830 | 0.60 | 9.0 | 830 |
| 1785 | 1734.92 | 66434 | 1.0 | 15.1 | 830 | 0.84 | 12.5 | 830 | 0.67 | 10.1 | 830 | 0.50 | 7.5 | 830 |

▲ Torque shown in 1,000 lb-in.

Gemini Ratings

Gemini Ratings Table

| Nominal Ratio | Gemini | | 1750 | | | 1450 | | | 1170 | | | 870 | | |
|---------------|-------------|-----------|---------|------|----------|---------|------|----------|---------|------|----------|---------|------|----------|
| | Exact Ratio | Gear Code | RPM Out | HP | Torque ▲ | RPM Out | HP | Torque ▲ | RPM Out | HP | Torque ▲ | RPM Out | HP | Torque ▲ |
| 11.02 | 11.84 | 00034 | 147.8 | 1968 | 798 | 122.5 | 1770 | 866 | 98.8 | 1522 | 923 | 73.5 | 1237 | 1,009 |
| 13.85 | 14.68 | 00044 | 119.2 | 1650 | 829 | 98.8 | 1482 | 899 | 79.7 | 1276 | 959 | 59.3 | 1037 | 1,048 |
| 17.21 | ... | ... | ... | ... | ... | ... | ... | ... | ... | ... | ... | ... | ... | ... |
| 20.41 | ... | ... | ... | ... | ... | ... | ... | ... | ... | ... | ... | ... | ... | ... |
| 24.00 | ... | ... | ... | ... | ... | ... | ... | ... | ... | ... | ... | ... | ... | ... |
| 31.63 | ... | ... | ... | ... | ... | ... | ... | ... | ... | ... | ... | ... | ... | ... |
| 36.56 | 39.30 | 00334 | 44.5 | 665 | 872 | 36.9 | 582 | 922 | 29.8 | 501 | 984 | 22.1 | 407 | 1,075 |
| 43.78 | 48.72 | 00344 | 35.9 | 665 | 1,081 | 29.8 | 597 | 1,172 | 24.0 | 501 | 1,219 | 17.9 | 396 | 1,297 |
| 54.45 | ... | ... | ... | ... | ... | ... | ... | ... | ... | ... | ... | ... | ... | ... |
| 64.42 | 60.39 | 00444 | 29.0 | 556 | 1,121 | 24.0 | 487 | 1,186 | 19.4 | 420 | 1,266 | 14.4 | 341 | 1,383 |
| 69.63 | 67.96 | 00634 | 25.8 | 422 | 958 | 21.3 | 370 | 1,013 | 17.2 | 318 | 1,080 | 12.8 | 259 | 1,181 |
| 80.01 | 84.24 | 00644 | 20.8 | 422 | 1,187 | 17.2 | 370 | 1,256 | 13.9 | 318 | 1,339 | 10.3 | 259 | 1,464 |
| 91.41 | 87.76 | 00834 | 19.9 | 345 | 1,011 | 16.5 | 303 | 1,070 | 13.3 | 260 | 1,141 | 9.9 | 212 | 1,247 |
| 99.38 | ... | ... | ... | ... | ... | ... | ... | ... | ... | ... | ... | ... | ... | ... |
| 111.5 | 108.79 | 00844 | 16.1 | 345 | 1,253 | 13.3 | 303 | 1,326 | 10.8 | 260 | 1,414 | 8.0 | 212 | 1,545 |
| 121.4 | 130.45 | 03334 | 13.4 | 294 | 1,249 | 11.1 | 256 | 1,310 | 9.0 | 222 | 1,410 | 6.7 | 180 | 1,541 |
| 138.5 | 138.72 | 02344 | 12.6 | 328 | 1,479 | 10.5 | 287 | 1,565 | 8.4 | 247 | 1,669 | 6.3 | 189 | 1,713 |
| 159.8 | 161.70 | 03344 | 10.8 | 294 | 1,549 | 9.0 | 258 | 1,638 | 7.2 | 217 | 1,707 | 5.4 | 162 | 1,719 |
| 174.8 | 171.96 | 02444 | 10.2 | 274 | 1,535 | 8.4 | 240 | 1,624 | 6.8 | 204 | 1,710 | 5.1 | 153 | 1,721 |
| 193.1 | 193.51 | 02634 | 9.0 | 208 | 1,311 | 7.5 | 182 | 1,387 | 6.0 | 150 | 1,414 | 4.5 | 112 | 1,420 |
| 206.2 | 200.44 | 04344 | 8.7 | 250 | 1,630 | 7.2 | 217 | 1,707 | 5.8 | 176 | 1,716 | 4.3 | 131 | 1,725 |
| 238.2 | 225.57 | 06334 | 7.8 | 201 | 1,472 | 6.4 | 176 | 1,558 | 5.2 | 151 | 1,661 | 3.9 | 119 | 1,750 |
| 265.4 | 248.46 | 04444 | 7.0 | 199 | 1,608 | 5.8 | 176 | 1,716 | 4.7 | 142 | 1,723 | 3.5 | 106 | 1,731 |
| 295.7 | 301.59 | 07344 | 5.8 | 172 | 1,691 | 4.8 | 145 | 1,722 | 3.9 | 118 | 1,728 | 2.9 | 87.9 | 1,735 |
| 330.1 | 346.58 | 06444 | 5.0 | 150 | 1,693 | 4.2 | 127 | 1,726 | 3.4 | 103 | 1,731 | 2.5 | 76.6 | 1,737 |
| 369.8 | 373.84 | 07444 | 4.7 | 139 | 1,695 | 3.9 | 118 | 1,728 | 3.1 | 95.2 | 1,733 | 2.3 | 71.0 | 1,738 |
| 412.1 | 432.99 | 33334 | 4.0 | 127 | 1,750 | 3.3 | 106 | 1,752 | 2.7 | 85.3 | 1,754 | 2.0 | 63.5 | 1,756 |
| 459 | 460.44 | 42334 | 3.8 | 120 | 1,751 | 3.1 | 99.4 | 1,752 | 2.5 | 80.3 | 1,754 | 1.9 | 59.7 | 1,756 |
| 532.5 | 536.72 | 43334 | 3.3 | 103 | 1,752 | 2.7 | 85.3 | 1,754 | 2.2 | 68.9 | 1,755 | 1.6 | 51.3 | 1,757 |
| 617.9 | 570.75 | 42434 | 3.1 | 96.7 | 1,752 | 2.5 | 80.2 | 1,754 | 2.0 | 64.8 | 1,756 | 1.5 | 48.3 | 1,758 |
| 660.6 | 642.29 | 62334 | 2.7 | 86.1 | 1,754 | 2.3 | 71.3 | 1,755 | 1.8 | 57.6 | 1,757 | 1.4 | 42.9 | 1,758 |
| 741.2 | 748.68 | 63334 | 2.3 | 73.9 | 1,755 | 1.9 | 61.2 | 1,756 | 1.6 | 49.4 | 1,757 | 1.2 | 36.8 | 1,759 |
| 900.3 | 824.67 | 44434 | 2.1 | 67.1 | 1,756 | 1.8 | 55.6 | 1,757 | 1.4 | 44.9 | 1,758 | 1.1 | 33.4 | 1,759 |
| 1057 | 1001.02 | 47334 | 1.7 | 55.3 | 1,757 | 1.4 | 45.9 | 1,758 | 1.2 | 37.0 | 1,759 | 0.9 | 27.5 | 1,760 |
| 1255 | 1150.36 | 64434 | 1.5 | 48.2 | 1,758 | 1.3 | 39.9 | 1,758 | 1.0 | 32.2 | 1,759 | 0.8 | 24.0 | 1,760 |
| 1450 | 1396.36 | 67334 | 1.3 | 39.7 | 1,758 | 1.0 | 32.9 | 1,759 | 0.8 | 26.6 | 1,760 | 0.6 | 19.7 | 1,760 |
| 1785 | 1730.87 | 67434 | 1.0 | 32.0 | 1,759 | 0.8 | 26.6 | 1,760 | 0.7 | 21.4 | 1,760 | 0.5 | 15.9 | 1,761 |

▲ Torque shown in 1,000 lb-in.

Hercules Ratings

Hercules Ratings Table

| Nominal Ratio | Hercules | | 1750 | | | 1450 | | | 1170 | | | 870 | | |
|---------------|-------------|-----------|---------|------|----------|---------|------|----------|---------|------|----------|---------|------|----------|
| | Exact Ratio | Gear Code | RPM Out | HP | Torque ▲ | RPM Out | HP | Torque ▲ | RPM Out | HP | Torque ▲ | RPM Out | HP | Torque ▲ |
| 11.02 | ... | ... | ... | ... | ... | ... | ... | ... | ... | ... | ... | ... | ... | ... |
| 13.85 | ... | ... | ... | ... | ... | ... | ... | ... | ... | ... | ... | ... | ... | ... |
| 17.21 | ... | ... | ... | ... | ... | ... | ... | ... | ... | ... | ... | ... | ... | ... |
| 20.41 | ... | ... | ... | ... | ... | ... | ... | ... | ... | ... | ... | ... | ... | ... |
| 24.00 | ... | ... | ... | ... | ... | ... | ... | ... | ... | ... | ... | ... | ... | ... |
| 31.63 | ... | ... | ... | ... | ... | ... | ... | ... | ... | ... | ... | ... | ... | ... |
| 36.56 | ... | ... | ... | ... | ... | ... | ... | ... | ... | ... | ... | ... | ... | ... |
| 43.78 | 47.80 | 00344 | 36.6 | 1115 | 1,779 | 30.3 | 978 | 1,883 | 24.5 | 841 | 2,008 | 18.2 | 684 | 2,195 |
| 54.45 | 59.25 | 00444 | 29.5 | 922 | 1,823 | 24.5 | 808 | 1,928 | 19.7 | 695 | 2,057 | 14.7 | 565 | 2,248 |
| 64.42 | 68.52 | 00544 | 25.5 | 823 | 1,883 | 21.2 | 722 | 1,992 | 17.1 | 621 | 2,125 | 12.7 | 505 | 2,322 |
| 69.63 | 71.21 | 00454 | 24.6 | 884 | 2,101 | 20.4 | 775 | 2,223 | 16.4 | 658 | 2,339 | 12.2 | 492 | 2,354 |
| 80.01 | 82.37 | 00554 | 21.2 | 798 | 2,195 | 17.6 | 700 | 2,323 | 14.2 | 571 | 2,347 | 10.6 | 427 | 2,361 |
| 91.41 | 88.15 | 00464 | 19.9 | 615 | 1,809 | 16.4 | 513 | 1,821 | 13.3 | 416 | 1,832 | 9.87 | 312 | 1,844 |
| 99.38 | 99.34 | 00654 | 17.6 | 700 | 2,322 | 14.6 | 586 | 2,346 | 11.8 | 475 | 2,356 | 8.76 | 355 | 2,367 |
| 111.5 | 106.59 | 00564 | 16.4 | 512 | 1,821 | 13.6 | 426 | 1,831 | 11.0 | 346 | 1,840 | 8.16 | 258 | 1,850 |
| 121.4 | 128.56 | 00664 | 13.6 | 427 | 1,831 | 11.3 | 355 | 1,840 | 9.10 | 288 | 1,847 | 6.77 | 215 | 1,856 |
| 138.5 | ... | ... | ... | ... | ... | ... | ... | ... | ... | ... | ... | ... | ... | ... |
| 159.8 | 158.64 | 03344 | 11.0 | 494 | 2,550 | 9.14 | 433 | 2,698 | 7.38 | 373 | 2,878 | 5.48 | 280 | 2,909 |
| 174.8 | ... | ... | ... | ... | ... | ... | ... | ... | ... | ... | ... | ... | ... | ... |
| 193.1 | 196.65 | 04344 | 8.9 | 425 | 2,720 | 7.37 | 373 | 2,878 | 5.95 | 313 | 2,992 | 4.42 | 233 | 2,995 |
| 206.2 | 227.44 | 03544 | 7.7 | 364 | 2,698 | 6.38 | 320 | 2,855 | 5.14 | 270 | 2,994 | 3.83 | 201 | 2,995 |
| 238.2 | 243.75 | 04444 | 7.2 | 351 | 2,786 | 5.95 | 308 | 2,948 | 4.80 | 252 | 2,994 | 3.57 | 188 | 2,995 |
| 265.4 | 274.31 | 06344 | 6.4 | 335 | 2,992 | 5.29 | 278 | 2,994 | 4.27 | 224 | 2,995 | 3.17 | 167 | 2,996 |
| 295.7 | 281.93 | 04544 | 6.2 | 326 | 2,992 | 5.14 | 270 | 2,994 | 4.15 | 218 | 2,995 | 3.09 | 162 | 2,996 |
| 330.1 | 340.02 | 06444 | 5.1 | 271 | 2,994 | 4.26 | 224 | 2,995 | 3.44 | 181 | 2,996 | 2.56 | 135 | 2,996 |
| 369.8 | 354.25 | 08344 | 4.9 | 260 | 2,994 | 4.09 | 215 | 2,995 | 3.30 | 174 | 2,996 | 2.46 | 129 | 2,997 |
| 412.1 | 439.12 | 08444 | 4.0 | 210 | 2,995 | 3.30 | 174 | 2,996 | 2.66 | 140 | 2,996 | 1.98 | 104 | 2,997 |
| 459.0 | 474.30 | 06644 | 3.7 | 194 | 2,995 | 3.06 | 161 | 2,996 | 2.47 | 130 | 2,997 | 1.83 | 96.5 | 2,997 |
| 532.5 | 507.88 | 08544 | 3.4 | 181 | 2,996 | 2.85 | 150 | 2,997 | 2.30 | 121 | 2,997 | 1.71 | 90.1 | 2,997 |
| 617.9 | 612.53 | 08644 | 2.9 | 150 | 2,996 | 2.37 | 125 | 2,997 | 1.91 | 101 | 2,997 | 1.42 | 74.8 | 2,999 |
| 660.6 | 652.70 | 43344 | 2.7 | 145 | 2,996 | 2.22 | 120 | 2,997 | 1.79 | 96.7 | 2,997 | 1.33 | 72.0 | 2,999 |
| 741.2 | 754.91 | 33544 | 2.3 | 125 | 2,997 | 1.92 | 104 | 2,997 | 1.55 | 83.6 | 2,997 | 1.15 | 62.2 | 2,999 |
| 900.3 | 910.46 | 63344 | 1.9 | 104 | 2,997 | 1.59 | 86.0 | 2,997 | 1.29 | 69.4 | 2,999 | 0.96 | 51.6 | 2,999 |
| 1057 | 1044.33 | 27444 | 1.7 | 90.4 | 2,997 | 1.39 | 75.0 | 2,999 | 1.12 | 60.5 | 2,999 | 0.83 | 45.0 | 2,999 |
| 1255 | 1217.33 | 74344 | 1.4 | 77.6 | 2,998 | 1.19 | 64.3 | 2,999 | 0.96 | 51.9 | 2,999 | 0.71 | 38.6 | 2,999 |
| 1450 | 1407.97 | 73544 | 1.2 | 67.1 | 2,999 | 1.03 | 55.6 | 2,999 | 0.83 | 44.9 | 2,999 | 0.62 | 33.4 | 2,999 |
| 1785 | 1698.08 | 76344 | 1.0 | 55.7 | 2,999 | 0.85 | 46.1 | 2,999 | 0.69 | 37.2 | 2,999 | 0.51 | 27.7 | 3,000 |

▲ Torque shown in 1,000 lb-in.

Thermal Horsepower Limits

Consult factory for drive thermal ratings without shaft fan cooling.

1750 RPM

| Ratio | Orion | Titan | Jupiter | Gemini | Hercules |
|--------|-------|-------|---------|--------|----------|
| | W/Fan | W/Fan | W/Fan | W/Fan | W/Fan |
| 11.02 | 73 | 62 | * | 0 | * |
| 13.85 | 77 | 130 | 61 | 22 | * |
| 17.21 | * | * | 106 | * | * |
| 20.41 | 80 | 195 | 123 | * | * |
| 24.00 | * | 214 | * | * | * |
| 31.63 | 40 | 80 | * | * | * |
| 36.56 | 43 | 80 | * | 58 | * |
| 43.78 | 46 | 87 | 68 | 77 | 83 |
| 54.45 | 46 | 93 | 76 | * | 115 |
| 64.42 | 47 | 90 | 96 | 111 | 135 |
| 69.63 | 47 | * | 81 | 108 | 140 |
| 80.01 | 48 | 101 | 103 | 121 | 151 |
| 91.41 | 48 | * | 114 | 123 | 153 |
| 99.38 | 48 | 102 | * | * | 155 |
| 111.50 | 48 | 105 | 119 | 137 | 160 |
| 121.40 | 48 | 106 | 117 | 139 | 160 |
| 138.50 | 48 | 106 | 120 | 139 | * |
| 159.80 | 48 | 106 | 120 | 139 | 160 |

1450 RPM

| Ratio | Orion | Titan | Jupiter | Gemini | Hercules |
|--------|-------|-------|---------|--------|----------|
| | W/Fan | W/Fan | W/Fan | W/Fan | W/Fan |
| 11.02 | 79 | 120 | * | 17 | * |
| 13.85 | 82 | 178 | 114 | 92 | * |
| 17.21 | * | * | 146 | * | * |
| 20.41 | 84 | 233 | 148 | * | * |
| 24.00 | * | 252 | * | * | * |
| 31.63 | 42 | 97 | * | * | * |
| 36.56 | 42 | 97 | * | 118 | * |
| 43.78 | 44 | 103 | 101 | 123 | 134 |
| 54.45 | 44 | 109 | 113 | * | 189 |
| 64.42 | 45 | 105 | 132 | 171 | 212 |
| 69.63 | 45 | * | 117 | 161 | 217 |
| 80.01 | 45 | 115 | 139 | 187 | 229 |
| 91.41 | 45 | * | 151 | 184 | 234 |
| 99.38 | 46 | 116 | * | * | 239 |
| 111.50 | 45 | 119 | 156 | 185 | 239 |
| 121.40 | 45 | 119 | 153 | 185 | 239 |
| 138.50 | 46 | 120 | 157 | 185 | * |
| 159.80 | 46 | 120 | 157 | 185 | 239 |

1170 RPM

| Ratio | Orion | Titan | Jupiter | Gemini | Hercules |
|--------|-------|-------|---------|--------|----------|
| | W/Fan | W/Fan | W/Fan | W/Fan | W/Fan |
| 11.02 | 85 | 158 | * | 104 | * |
| 13.85 | 87 | 203 | 147 | 134 | * |
| 17.21 | * | * | 216 | * | * |
| 20.41 | 89 | 246 | 215 | * | * |
| 24.00 | * | 258 | * | * | * |
| 31.63 | 42 | 101 | * | * | * |
| 36.56 | 42 | 101 | * | 147 | * |
| 43.78 | 44 | 105 | 127 | 167 | 197 |
| 54.45 | 44 | 110 | 146 | * | 246 |
| 64.42 | 44 | 107 | 165 | 216 | 266 |
| 69.63 | 44 | * | 151 | 203 | 270 |
| 80.01 | 44 | 114 | 172 | 203 | 281 |
| 91.41 | 45 | * | 182 | 203 | 285 |
| 99.38 | 45 | 116 | * | * | 289 |
| 111.50 | 45 | 118 | 187 | 203 | 291 |
| 121.40 | 45 | 118 | 185 | 203 | 307 |
| 138.50 | 45 | 118 | 188 | 203 | * |
| 159.80 | 45 | 118 | 188 | 203 | 307 |

870 RPM

| Ratio | Orion | Titan | Jupiter | Gemini | Hercules |
|--------|-------|-------|---------|--------|----------|
| | W/Fan | W/Fan | W/Fan | W/Fan | W/Fan |
| 11.02 | 90 | 186 | * | 140 | * |
| 13.85 | 91 | 216 | 198 | 181 | * |
| 17.21 | * | * | 228 | * | * |
| 20.41 | 92 | 245 | 268 | * | * |
| 24.00 | * | 254 | * | * | * |
| 31.63 | 43 | 101 | * | * | * |
| 36.56 | 42 | 101 | * | 175 | * |
| 43.78 | 43 | 104 | 158 | 213 | 261 |
| 54.45 | 43 | 107 | 185 | * | 300 |
| 64.42 | 43 | 106 | 200 | 253 | 317 |
| 69.63 | 43 | * | 188 | 243 | 323 |
| 80.01 | 43 | 110 | 206 | 261 | 328 |
| 91.41 | 43 | * | 215 | 260 | 331 |
| 99.38 | 43 | 111 | * | * | 333 |
| 111.50 | 43 | 112 | 218 | 270 | 335 |
| 121.40 | 43 | 113 | 217 | 270 | 348 |
| 138.50 | 43 | 113 | 219 | 270 | * |
| 159.80 | 43 | 113 | 219 | 270 | 348 |

NOTE: Application-adjusted thermal ratings must be calculated using the Ambient Temperature Adjustment Factors on **page 17** before comparing to the required load. For cooling beyond the range of values listed, contact the Factory. Thermal ratings are calculated assuming a 200°F sump temperature, but actual sump temperatures will vary based upon exact ambient conditions and load profile.

* Ratio is not available as catalog standard – special engineering required.

Ambient Temperature Adjustment Factor & Overhung Load Capacity

Ambient Temperature Adjustment Factor (Ac)

| Ambient Temperature (°F) | Percent of Operational Time Per Hour | | |
|--------------------------|--------------------------------------|------|------|
| | 100% | 75% | 50% |
| below 54 | 1.20 | 1.27 | 1.40 |
| 55 to 69 | 1.10 | 1.17 | 1.29 |
| 70 to 84 | 1.00 | 1.06 | 1.17 |
| 85 to 99 | 0.85 | 0.90 | 0.99 |
| 100 to 114 | 0.70 | 0.74 | 0.81 |
| above 115 | Consult Factory | | |

Overhung Load Capacity

| Distance (in) * | Load Location Factor (L1) - High-Speed Shaft | | | |
|-----------------|--|--------------------|---|---|
| | Orion (qu) Titan (qu) | Orion Orion (q) | Titan, Titan (q) Jupiter, Jupiter (q) Gemini, Gemini (q) Gemini (qu) | Hercules Hercules (q) Hercules (qu) |
| 3/4 | 0.80 | 0.73 | 0.70 | 0.73 |
| 1 | 0.85 | 0.78 | 0.74 | 0.76 |
| 1-1/4 | 0.89 | 0.82 | 0.79 | 0.79 |
| 1-1/2 | 0.93 | 0.87 | 0.83 | 0.82 |
| 1-3/4 | 0.98 | 0.92 | 0.87 | 0.85 |
| 2 | 1.02 | 0.97 | 0.91 | 0.88 |
| 2-1/4 | 1.07 | 1.03 | 0.96 | 0.91 |
| 2-1/2 | 1.11 | 1.08 | 1.00 | 0.94 |
| 2-3/4 | 1.15 | 1.13 | 1.04 | 0.97 |
| 3 | 1.2 | 1.18 | 1.09 | 1.00 |
| 3-1/4 | 1.25 | 1.23 | 1.13 | 1.03 |
| 3-1/2 | 1.31 | 1.28 | 1.17 | 1.06 |
| 3-3/4 | 1.38 | 1.33 | 1.21 | 1.09 |
| 4 | 1.44 | 1.38 | 1.26 | 1.12 |
| 4-1/4 | 1.50 | 1.43 | 1.31 | 1.15 |
| 4-1/2 | ... | 1.49 | 1.37 | 1.18 |
| 4-3/4 | ... | ... | 1.42 | 1.21 |
| 5 | ... | ... | 1.47 | 1.24 |
| 5-1/2 | ... | ... | 1.58 | 1.30 |
| 6 | ... | ... | ... | 1.36 |
| 6-1/2 | ... | ... | ... | 1.42 |

| H.S. Shaft RPM ■ | Overhung Load Capacity (lbf) - High-Speed Shaft | | | |
|------------------|---|--------------------|---|---|
| | Orion (qu) Titan (qu) | Orion Orion (q) | Titan, Titan (q) Jupiter, Jupiter (q) Gemini, Gemini (q) Gemini (qu) | Hercules Hercules (q) Hercules (qu) |
| 1750 | 941 | 1,500 | 1,900 | 2,500 |
| 1430 | 999 | 1,600 | 2,040 | 2,660 |
| 1170 | 1,060 | 1,700 | 2,160 | 2,830 |
| 870 | 1,160 | 1,860 | 2,360 | 3,100 |
| 720 | 1,230 | 1,960 | 2,500 | 3,270 |
| 580 | 1,310 | 2,100 | 2,670 | 3,490 |

★ Interpolate for intermediate values.

■ If desired speed is not shown, use next higher speed.

s = single reduction d = double reduction t = triple reduction q = quadruple reduction qu = quintuple reduction

| Distance (in) | Orion Factor | Titan Jupiter Gemini Factor |
|---------------|--------------|--------------------------------------|
|---------------|--------------|--------------------------------------|

SMP High Overhung Load LLF (L1) High-Speed Shaft — (d, t, q)

| | | |
|------|------|------|
| 0.25 | ... | 0.77 |
| 0.50 | ... | 0.80 |
| 0.75 | 0.81 | 0.82 |
| 1.00 | 0.85 | 0.85 |
| 1.25 | 0.89 | 0.88 |
| 1.50 | 0.93 | 0.90 |
| 1.75 | 0.97 | 0.92 |
| 2.00 | 1.01 | 0.95 |
| 2.25 | 1.04 | 0.97 |
| 2.50 | 1.08 | 1.00 |
| 2.75 | 1.12 | 1.02 |
| 3.00 | 1.16 | 1.05 |
| 3.25 | 1.20 | 1.07 |
| 3.50 | 1.24 | 1.10 |
| 3.75 | 1.27 | 1.12 |
| 4.00 | 1.31 | 1.15 |
| 4.25 | 1.35 | 1.17 |
| 4.50 | 1.39 | 1.20 |
| 4.75 | 1.43 | 1.22 |
| 5.00 | 1.47 | 1.25 |
| 5.25 | 1.54 | 1.28 |
| 5.50 | 1.62 | 1.30 |
| 5.75 | 1.70 | 1.32 |
| 6.00 | 1.78 | 1.35 |
| 6.50 | 1.85 | 1.40 |
| 7.00 | ... | 1.45 |
| 7.50 | ... | 1.50 |
| 8.00 | ... | 1.55 |
| 8.50 | ... | 1.60 |
| 9.00 | ... | 1.65 |

SMP High Overhung Load Capacity (lbf) High-Speed Shaft

| | | |
|------|------|------|
| 1750 | 3560 | 5510 |
| 1430 | 3790 | 5860 |
| 1170 | 4020 | 6220 |
| 870 | 4400 | 6800 |
| 720 | 4650 | 7200 |
| 580 | 4950 | 7670 |

One and Two-Step Shaft

Shaft Mount Flange B.C.

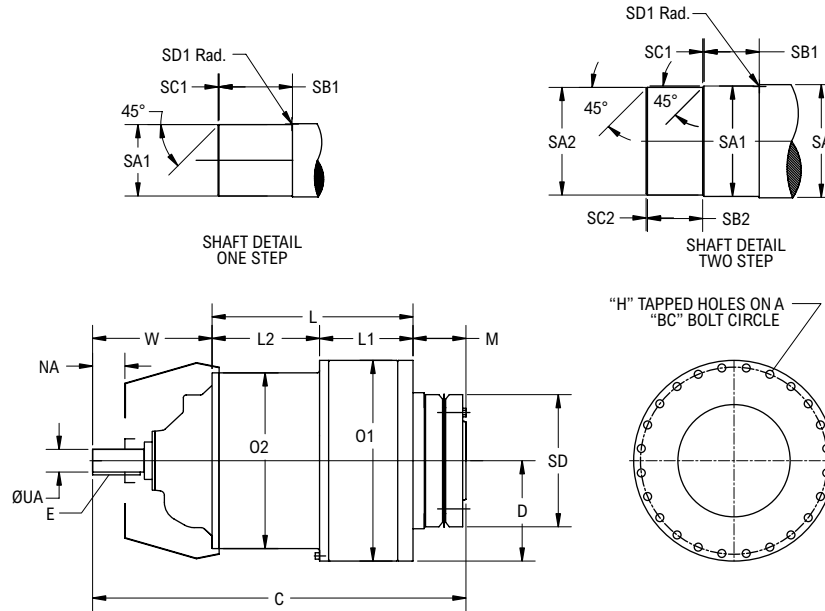

Dimensions (in)

| Series | SA (Ø) | SA1 (Ø) | SB1 | SC1 | SD1 | SA2 (Ø) | SB2 | SC2 | SD2 | H | B.C. (Ø) | M |
|----------|--------|---------|-------|-------|------|---------|-------|-------|--------|----------|----------|------|
| Orion | ... | 5.313 | 6.102 | 0.110 | 0.06 | ... | ... | ... | 11.811 | (24) M16 | 17.250 | 4.65 |
| Orion | ... | 5.437 | 6.102 | 0.110 | 0.06 | ... | ... | ... | 11.811 | (24) M16 | 17.250 | 4.65 |
| Titan | ... | 5.708 | 7.480 | 0.120 | 0.06 | ... | ... | ... | 12.992 | (24) M20 | 20.625 | 5.17 |
| Titan | ... | 6.299 | 7.480 | 0.120 | 0.06 | ... | ... | ... | 14.567 | (24) M20 | 20.625 | 5.17 |
| Titan | ... | 6.436 | 7.480 | 0.120 | 0.06 | ... | ... | ... | 14.567 | (24) M20 | 20.625 | 5.17 |
| Titan | ... | 6.692 | 7.480 | 0.120 | 0.06 | ... | ... | ... | 15.945 | (24) M20 | 20.625 | 5.17 |
| Titan | ... | 7.480 | 7.480 | 0.120 | 0.06 | ... | ... | ... | 15.945 | (24) M20 | 20.625 | 5.17 |
| Jupiter | 7.874 | 7.480 | 3.937 | 0.098 | 0.06 | 7.677 | 3.937 | 0.098 | 16.929 | (32) M20 | 22.375 | 7.02 |
| Jupiter | 8.268 | 7.874 | 3.937 | 0.098 | 0.06 | 7.677 | 3.937 | 0.098 | 16.929 | (32) M20 | 22.375 | 7.02 |
| Gemini | 10.236 | 9.843 | 4.724 | 0.098 | 0.06 | 9.646 | 4.724 | 0.098 | 20.472 | (32) M24 | 26.125 | 8.67 |
| Hercules | 12.210 | 11.811 | 5.021 | 0.098 | 0.06 | 11.614 | 5.021 | 0.098 | 25.394 | (32) M24 | 33.375 | 9.34 |

| Series | NA | | | | UA | | E | |
|----------|---------|------|---------|------|---------|-------|-------------------|-------------------|
| | w/o Fan | | w/Fan | | d, t, q | qu | d, t, q | qu |
| | d, t, q | qu | d, t, q | qu | | | | |
| Orion | 4.50 | 4.25 | 3.25 | 2.88 | 2.125 | 1.875 | 1/2 x 1/2 x 4 | 1/2 x 1/2 x 3-3/4 |
| Titan | 5.68 | 4.25 | 3.56 | 2.88 | 2.500 | 1.875 | 5/8 x 5/8 x 5-1/8 | 1/2 x 1/2 x 3-3/4 |
| Jupiter | 6.50 | 5.68 | 4.11 | 3.56 | 2.500 | 2.500 | 5/8 x 5/8 x 6 | 5/8 x 5/8 x 5-1/8 |
| Gemini | 6.50 | 5.68 | 4.11 | 3.56 | 2.500 | 2.500 | 5/8 x 5/8 x 6 | 5/8 x 5/8 x 5-1/8 |
| Hercules | 6.50 | 6.50 | 4.38 | 4.38 | 3.000 | 3.000 | 3/4 x 3/4 x 5-7/8 | 3/4 x 3/4 x 5-7/8 |

| Series | C | | D | L | | L2 | | L1 | | O1 | O2 | W | |
|----------|---------|-------|-------|---------|-------|---------|-------|---------|-------|-------|-------|---------|-------|
| | d, t, q | qu | | d, t, q | qu | d, t, q | qu | d, t, q | qu | | | d, t, q | qu |
| Orion | 33.36 | 34.98 | 9.19 | 17.27 | 17.33 | 8.64 | 8.70 | 8.63 | 8.63 | 18.38 | 14.37 | 11.44 | 13.00 |
| Titan | 40.49 | 39.88 | 11.06 | 22.16 | 21.91 | 11.86 | 11.61 | 10.30 | 10.30 | 22.13 | 19.37 | 13.16 | 12.80 |
| Jupiter | 47.30 | 49.93 | 12.00 | 26.30 | 29.75 | 12.36 | 15.81 | 13.94 | 13.94 | 24.00 | 20.40 | 13.98 | 13.16 |
| Gemini | 53.38 | 56.01 | 13.88 | 30.73 | 34.18 | 12.36 | 15.81 | 18.37 | 18.37 | 27.75 | 20.40 | 13.98 | 13.16 |
| Hercules | 65.75 | 65.75 | 17.75 | 42.16 | 42.16 | 23.20 | 23.20 | 18.96 | 18.96 | 35.50 | 26.75 | 14.25 | 14.25 |

s = single reduction d = double reduction t = triple reduction q = quadruple reduction qu = quintuple reduction

NOTE: Dimensions subject to change. Certified dimensions of ordered material furnished upon request.

One and Two-Step Shaft — Heavy-Duty

Shaft Mount Flange B.C.

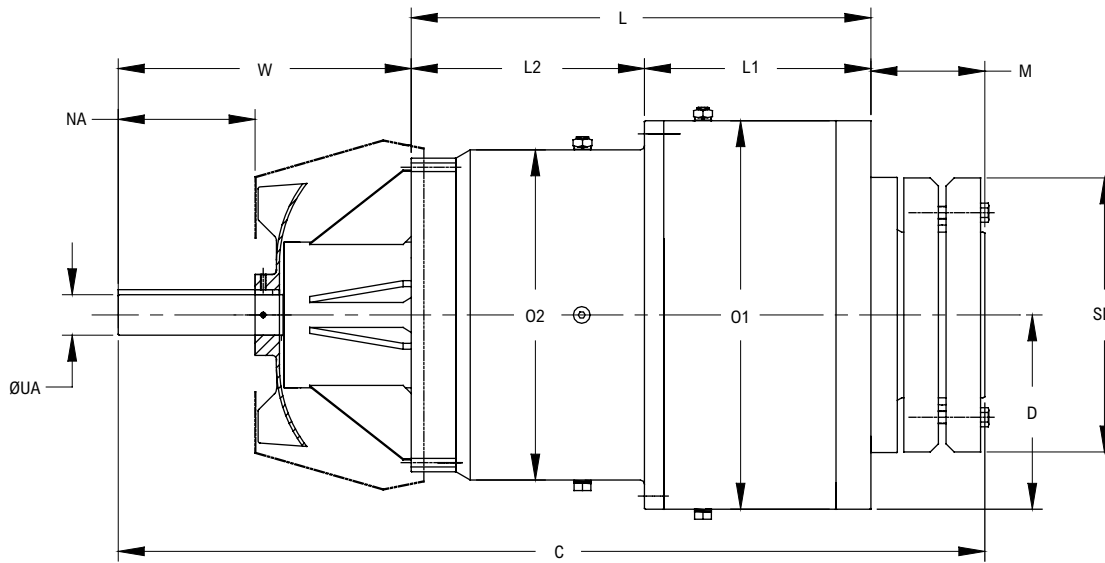

Dimensions (in)

| Series | SA (Ø) | SA1 (Ø) | SB1 | SC1 | SD1 | SA2 (Ø) | SB2 | SC2 | SD2 | H | B.C. (Ø) | M |
|---------|--------|---------|-------|-------|------|---------|-------|-------|--------|----------|----------|------|
| Orion | ... | 5.315 | 6.102 | 0.110 | 0.06 | ... | ... | ... | 11.811 | (24) M16 | 17.250 | 4.65 |
| Titan | ... | 6.299 | 7.480 | 0.120 | 0.06 | ... | ... | ... | 13.000 | (24) M20 | 20.625 | 5.17 |
| Jupiter | 8.268 | 7.874 | 3.937 | 0.098 | 0.06 | 7.677 | 3.937 | 0.098 | 16.929 | (32) M20 | 22.375 | 7.02 |
| Gemini | 10.236 | 9.843 | 4.724 | 0.098 | 0.06 | 9.646 | 4.724 | 0.098 | 20.472 | (32) M24 | 26.125 | 8.67 |

| Series | NA | | UA | W | E | C | D | L | L2 | L1 | O1 | O2 |
|---------|---------|-------|-------|-------|-------------------|-------|-------|-------|-------|-------|-------|-------|
| | w/o Fan | w/Fan | | | | | | | | | | |
| Orion | 7.93 | 5.06 | 2.130 | 13.88 | 1/2 x 1/2 x 4 | 37.05 | 9.19 | 18.52 | 9.89 | 8.63 | 18.38 | 14.37 |
| Titan | 9.19 | 7.43 | 2.500 | 17.04 | 5/8 x 5/8 x 8-1/2 | 46.37 | 11.06 | 24.16 | 13.86 | 10.30 | 22.13 | 19.37 |
| Jupiter | 10.19 | 8.43 | 2.500 | 18.04 | 5/8 x 5/8 x 9-1/2 | 53.36 | 12.00 | 28.30 | 14.36 | 13.94 | 24.00 | 20.40 |
| Gemini | 10.19 | 8.43 | 2.500 | 18.04 | 5/8 x 5/8 x 9-1/2 | 59.44 | 13.88 | 32.73 | 14.36 | 18.37 | 27.75 | 20.40 |

s = single reduction d = double reduction t = triple reduction q = quadruple reduction qu = quintuple reduction

NOTE: Dimensions subject to change. Certified dimensions of ordered material furnished upon request.

Top Motor Mount & Torque Arm

Shaft Mount

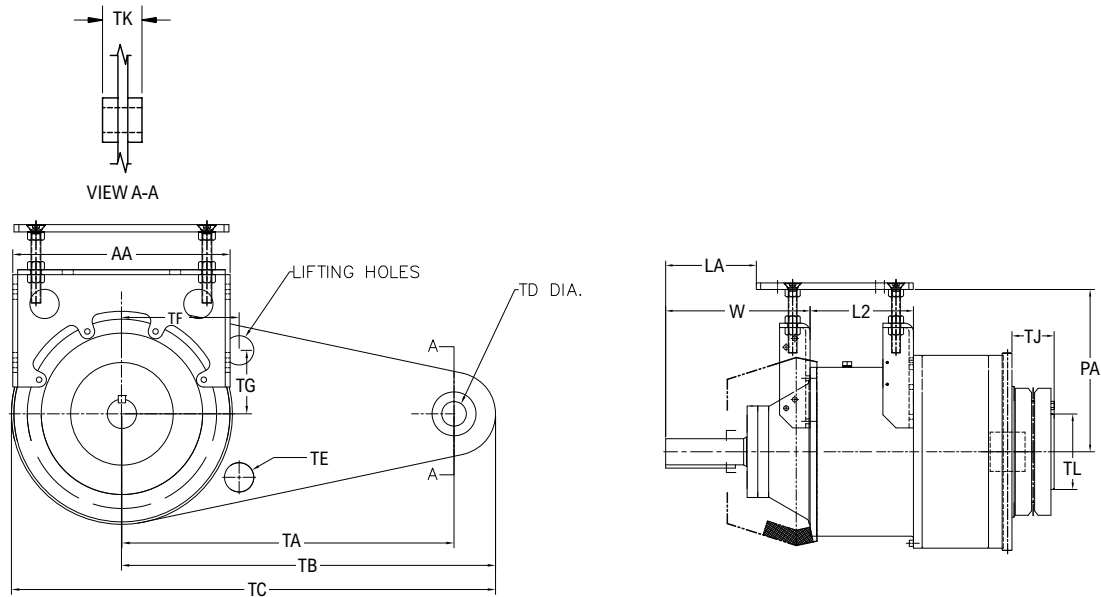

Dimensions (in)

| Series | AA | C | | L2 | | LA | | PA | | W | | TA | TB | TC |
|----------|-------|---------|-------|---------|-------|---------|-------|-------|-------|---------|-------|-------|-------|-------|
| | | d, t, q | qu | d, t, q | qu | d, t, q | qu | min. | max. | d, t, q | qu | | | |
| Orion | 19.00 | 33.36 | 34.98 | 8.64 | 8.70 | 6.69 | 8.19 | 13.35 | 16.53 | 11.44 | 13.00 | 34.00 | 38.25 | 48.75 |
| Titan | 22.25 | 40.49 | 39.88 | 11.86 | 11.61 | 7.66 | 7.06 | 16.72 | 20.52 | 13.16 | 12.80 | 34.00 | 38.25 | 49.56 |
| Jupiter | 27.25 | 47.30 | 49.93 | 12.36 | 15.81 | 7.95 | 7.95 | 16.85 | 20.52 | 13.98 | 13.16 | 43.31 | 48.31 | 64.31 |
| Gemini | 22.25 | 53.38 | 56.01 | 12.36 | 15.81 | 7.50 | 7.88 | 16.75 | 20.50 | 13.98 | 13.16 | 59.06 | 65.31 | 81.31 |
| Hercules | 30.00 | 65.75 | 65.75 | 23.20 | 23.20 | 10.25 | 10.25 | 19.19 | 22.63 | 14.25 | 14.25 | 72.83 | 80.34 | 98.08 |

| Series | TG | TF | TK | TE (Ø) | TD (Ø) ■ | TJ | TH | TL (Ø) |
|----------|--------|-------|------|--------|----------|-------|-------|--------|
| Orion | 6.000 | 11.00 | 4.00 | 3.00 | 2.520 | 3.650 | 2.220 | 6.890 |
| Titan | 6.500 | 12.00 | 4.00 | 3.00 | 2.520 | 4.170 | 2.669 | 7.284 |
| Jupiter | 8.250 | 12.50 | 4.33 | 3.00 | 5.020 | 6.141 | 4.415 | 10.236 |
| Gemini | 8.8750 | 13.50 | 4.00 | 3.00 | 6.375 | 7.291 | 6.041 | 12.598 |
| Hercules | 12.375 | 15.25 | 4.00 | 3.00 | 7.188 | 7.466 | 6.466 | 14.961 |

| Motor Frame Size ▲ | | | | | | | | | |
|--------------------|-----------|-----------|-----------|-----------|------------|------------|--------------|-------------|---------------|
| Orion | Titan | Jupiter | Gemini | Hercules | Orion HD ● | Titan HD ● | Jupiter HD ● | Gemini HD ● | Hercules HD ● |
| 213T/215T | 213T/215T | 213T/215T | 213T/215T | 213T/215T | 213T/215T | 213T/215T | 213T/215T | 213T/215T | 213T/215T |
| 254T/256T | 254T/256T | 254T/256T | 254T/256T | 254T/256T | 254T/256T | 254T/256T | 254T/256T | 254T/256T | 254T/256T |
| 284T/286T | 284T/286T | 284T/286T | 284T/286T | 284T/286T | 284T/286T | 284T/286T | 284T/286T | 284T/286T | 284T/286T |
| 324T/326T | 324T/326T | 324T/326T | 324T/326T | 324T/326T | 324T/326T | 324T/326T | 324T/326T | 324T/326T | 324T/326T |
| 364T/365T | 364T/365T | 364T/365T | 364T/365T | 364T/365T | 364T/365T | 364T/365T | 364T/365T | 364T/365T | 364T/365T |
| 404T/405T | 404T/405T | 404T/405T | 404T/405T | 404T/405T | 404T/405T | 404T/405T | 404T/405T | 404T/405T | 404T/405T |
| 444T/445T | 444T/445T | 444T/445T | 444T/445T | 444T/445T | 444T/445T | 444T/445T | 444T/445T | 444T/445T | 444T/445T |

| Series Heavy-Duty d,t,q | AA | C | | L2 | | LA | | PA | | W | TA | TB |
|-------------------------|-------|---------|---------|---------|-------|-------|-------|-------|-------|---|----|----|
| | | d, t, q | s, d, t | d, t, q | min. | max. | | | | | | |
| Orion | 19.00 | 37.05 | 9.89 | 9.56 | 13.35 | 16.53 | 13.88 | 34.00 | 38.25 | | | |
| Titan | 22.25 | 46.37 | 13.86 | 13.53 | 16.72 | 20.52 | 17.04 | 34.00 | 38.25 | | | |
| Jupiter | 23.75 | 53.36 | 14.36 | 13.04 | 16.85 | 20.52 | 18.04 | 43.31 | 48.31 | | | |
| Gemini | 23.75 | 59.44 | 14.36 | 10.75 | 16.75 | 20.50 | 18.04 | 59.06 | 65.31 | | | |

| Series Heavy-Duty d,t,q | TC | TG | TF | TK | TE (Ø) | TD (Ø) ■ | TJ | TH | TL (Ø) |
|-------------------------|-------|-------|-------|------|--------|----------|-------|-------|--------|
| | | | | | | | | | |
| Titan | 49.56 | 6.500 | 12.00 | 4.00 | 3.00 | 2.520 | 4.170 | 2.669 | 7.284 |
| Jupiter | 64.31 | 8.250 | 12.50 | 4.33 | 3.00 | 5.020 | 6.141 | 4.415 | 10.236 |
| Gemini | 81.31 | 8.875 | 13.50 | 4.00 | 3.00 | 6.375 | 7.291 | 6.041 | 12.598 |

▲ Contact factory for motor frame sizes other than "T" frame motors.

■ TOLERANCES: 3.000" Diameter or less +.000/-0.01

● Heavy-Duty

s = single reduction d = double reduction t = triple reduction q = quadruple reduction qu = quintuple reduction

NOTE: Dimensions subject to change. Certified dimensions of ordered material furnished upon request.

Belt Guards

Shaft Mount

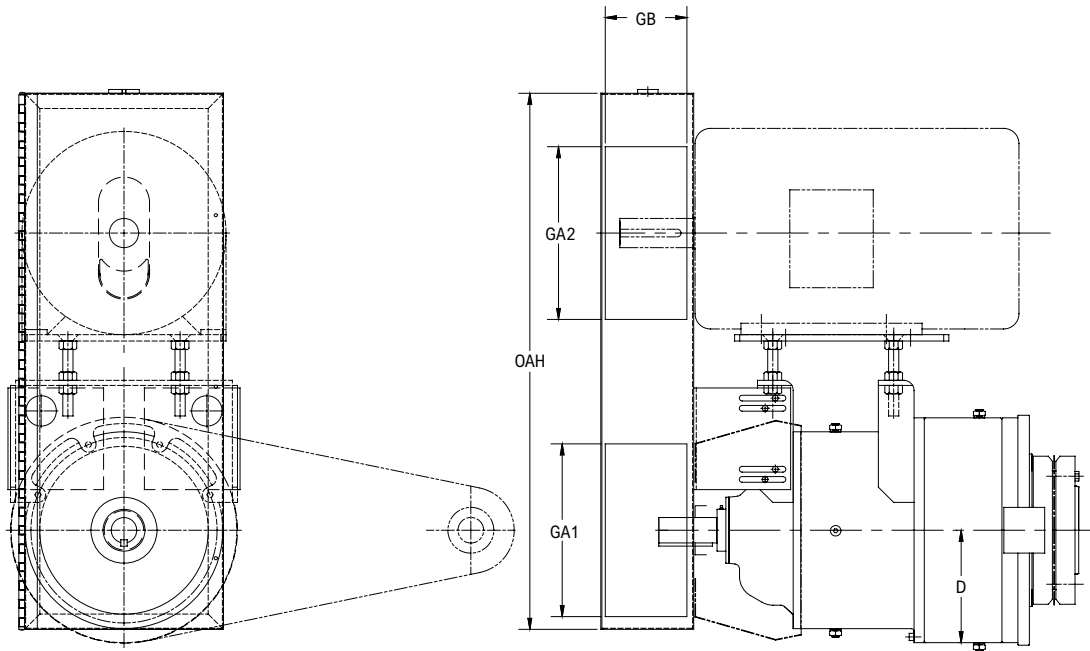

Dimensions (in) ▲

| Series | D | GA1 | GA2 | GB | OAH | Motor Size Range |
|----------|--------------------|----------------------|--------------------|------------------|----------------|------------------|
| | Base to Centerline | Max Sheave Ø Reducer | Max Sheave Ø Motor | Max Sheave Width | Overall Height | |
| Orion | 9.19 | 15.00 | 15.00 | 8.00 | 43.50 | 215T-286T |
| | | | | | 50.25 | 324T-405T |
| Titan | 11.06 | 17.00 | 17.00 | 8.00 | 48.00 | 215T-286T |
| | | | | | 53.75 | 324T-445T |
| Jupiter | 12.00 | 17.00 | 17.00 | 8.00 | 48.00 | 215T-286T |
| | | | | | 53.75 | 324T-445T |
| Gemini | 13.88 | 17.00 | 17.00 | 8.00 | 48.00 | 215T-286T |
| | | | | | 53.75 | 324T-445T |
| Hercules | 17.75 | 19.50 | 19.50 | 8.00 | 53.38 | 215T-286T |
| | | | | | 57.50 | 324T-445T |

| Series Heavy-Duty | D | GA1 | GA2 | GB | OAH | Motor Size Range |
|-------------------|--------------------|----------------------|--------------------|------------------|----------------|------------------|
| | Base to Centerline | Max Sheave Ø Reducer | Max Sheave Ø Motor | Max Sheave Width | Overall Height | |
| Orion | 9.19 | 15.00 | 15.00 | 8.00 | 43.50 | 215T-286T |
| | | | | | 50.25 | 324T-405T |
| Titan | 11.06 | 17.00 | 17.00 | 8.00 | 48.00 | 215T-286T |
| | | | | | 53.75 | 324T-445T |
| Jupiter | 12.00 | 17.00 | 17.00 | 8.00 | 48.00 | 215T-286T |
| | | | | | 53.75 | 324T-445T |
| Gemini | 13.88 | 17.00 | 17.00 | 8.00 | 53.38 | 215T-286T |
| | | | | | 57.50 | 324T-445T |
| Hercules | 13.88 | 19.50 | 19.50 | 8.00 | 53.38 | 215T-286T |
| | | | | | 57.50 | 324T-445T |

▲ Guards based on synchronous belt with ratio not to exceed 2.5:1.

NOTE: Dimensions subject to change. Certified dimensions of ordered material furnished upon request.

Integral

Shaft Mount

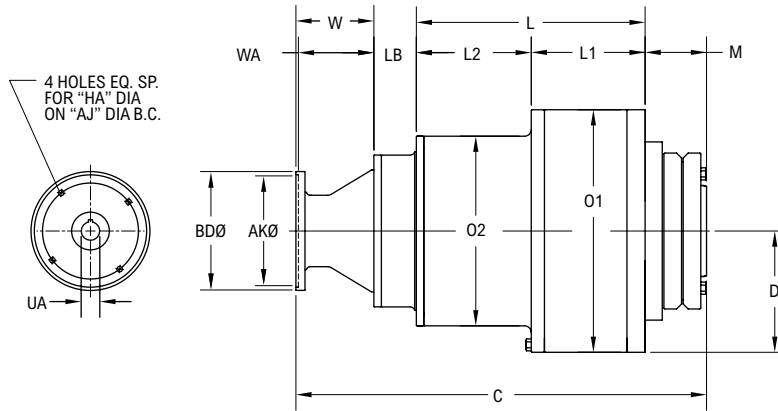

Dimensions (in)

| Series | Frame Size | HA (Ø) | AJ (Ø) | UA | BD (Ø) | AK (Ø) | W | WA | L | L2 | L1 | M | C | D | LB | O1 | O2 |
|------------------|-------------|--------|--------|-------|--------|--------|------|------|-------|------|------|-------|-------|------|------|-------|-------|
| Orion (d,t,q) | 143TC-145TC | 0.38 | 5.875 | 0.875 | 6.63 | 4.50 | 4.86 | 4.67 | 17.33 | 8.70 | 8.63 | 4.650 | 30.06 | 9.19 | 3.22 | 18.38 | 14.37 |
| | 182TC-184TC | 0.50 | 7.250 | 1.125 | 9.00 | 8.50 | 5.91 | 5.72 | 17.33 | 8.70 | 8.63 | 4.650 | 31.11 | 9.19 | 3.22 | 18.38 | 14.37 |
| | 213TC-215TC | 0.50 | 7.250 | 1.375 | 9.00 | 8.50 | 5.91 | 5.72 | 17.33 | 8.70 | 8.63 | 4.650 | 31.11 | 9.19 | 3.22 | 18.38 | 14.37 |
| | 254TC-256TC | 0.50 | 7.250 | 1.625 | 9.00 | 8.50 | 5.91 | 5.72 | 17.33 | 8.70 | 8.63 | 4.650 | 31.11 | 9.19 | 3.22 | 18.38 | 14.37 |
| | 284TC-286TC | 0.50 | 9.000 | 1.875 | 11.00 | 10.50 | 6.06 | 5.87 | 17.33 | 8.70 | 8.63 | 4.650 | 31.26 | 9.19 | 3.22 | 18.38 | 14.37 |

| Series | Frame Size | HA (Ø) | AJ (Ø) | UA | BD (Ø) | AK (Ø) | W | WA | L | L2 | L1 | M | C | D | LB | O1 | O2 |
|---------------|-------------|--------|--------|-------|--------|--------|------|------|-------|------|------|-------|-------|------|------|-------|-------|
| Orion (qu) | 143TC-145TC | 0.38 | 5.875 | 0.875 | 6.63 | 4.50 | 4.86 | 4.67 | 17.33 | 8.70 | 8.63 | 4.650 | 30.06 | 9.19 | 3.22 | 18.38 | 14.37 |
| | 182TC-184TC | 0.50 | 7.250 | 1.125 | 9.00 | 8.50 | 5.91 | 5.72 | 17.33 | 8.70 | 8.63 | 4.650 | 31.11 | 9.19 | 3.22 | 18.38 | 14.37 |
| | 213TC-215TC | 0.50 | 7.250 | 1.375 | 9.00 | 8.50 | 5.91 | 5.72 | 17.33 | 8.70 | 8.63 | 4.650 | 31.11 | 9.19 | 3.22 | 18.38 | 14.37 |
| | 254TC-256TC | 0.50 | 7.250 | 1.625 | 9.00 | 8.50 | 5.91 | 5.72 | 17.33 | 8.70 | 8.63 | 4.650 | 31.11 | 9.19 | 3.22 | 18.38 | 14.37 |
| | 284TC-286TC | 0.50 | 9.000 | 1.875 | 11.00 | 10.50 | 6.06 | 5.87 | 17.33 | 8.70 | 8.63 | 4.650 | 31.26 | 9.19 | 3.22 | 18.38 | 14.37 |

| Series | Frame Size | HA (Ø) | AJ (Ø) | UA | BD (Ø) | AK (Ø) | W | WA | L | L2 | L1 | M | C | D | LB | O1 | O2 |
|---------------|-------------|--------|--------|-------|--------|--------|------|------|-------|-------|-------|------|-------|-------|------|-------|-------|
| Titan (qu) | 143TC-145TC | 0.38 | 5.875 | 0.875 | 6.63 | 4.50 | 4.86 | 4.67 | 21.91 | 11.61 | 10.30 | 5.17 | 34.96 | 11.06 | 3.02 | 22.13 | 19.37 |
| | 182TC-184TC | 0.50 | 7.250 | 1.125 | 9.00 | 8.50 | 5.91 | 5.72 | 21.91 | 11.61 | 10.30 | 5.17 | 36.01 | 11.06 | 3.02 | 22.13 | 19.37 |
| | 213TC-215TC | 0.50 | 7.250 | 1.375 | 9.00 | 8.50 | 5.91 | 5.72 | 21.91 | 11.61 | 10.30 | 5.17 | 36.01 | 11.06 | 3.02 | 22.13 | 19.37 |
| | 254TC-256TC | 0.50 | 7.250 | 1.625 | 9.00 | 8.50 | 5.91 | 5.72 | 21.91 | 11.61 | 10.30 | 5.17 | 36.01 | 11.06 | 3.02 | 22.13 | 19.37 |
| | 284TC-286TC | 0.50 | 9.000 | 1.875 | 11.00 | 10.50 | 6.06 | 5.87 | 21.91 | 11.61 | 10.30 | 5.17 | 36.16 | 11.06 | 3.02 | 22.13 | 19.37 |

| Series | Frame Size | HA (Ø) | AJ (Ø) | UA | BD (Ø) | AK (Ø) | W | WA | L | L2 | L1 | M | C | D | LB | O1 | O2 |
|------------------|-------------|--------|--------|-------|--------|--------|------|------|-------|-------|-------|------|-------|-------|------|-------|-------|
| Titan (d,t,q) | 143TC-145TC | 0.38 | 5.875 | 0.875 | 6.63 | 4.50 | 4.86 | 4.67 | 21.91 | 11.61 | 10.30 | 5.17 | 34.96 | 11.06 | 3.02 | 22.13 | 19.37 |
| | 182TC-184TC | 0.50 | 7.250 | 1.125 | 9.00 | 8.50 | 5.91 | 5.72 | 21.91 | 11.61 | 10.30 | 5.17 | 36.01 | 11.06 | 3.02 | 22.13 | 19.37 |
| | 213TC-215TC | 0.50 | 7.250 | 1.375 | 9.00 | 8.50 | 5.91 | 5.72 | 21.91 | 11.61 | 10.30 | 5.17 | 36.01 | 11.06 | 3.02 | 22.13 | 19.37 |
| | 254TC-256TC | 0.50 | 7.250 | 1.625 | 9.00 | 8.50 | 5.91 | 5.72 | 21.91 | 11.61 | 10.30 | 5.17 | 36.01 | 11.06 | 3.02 | 22.13 | 19.37 |
| | 284TC-286TC | 0.50 | 9.000 | 1.875 | 11.00 | 10.50 | 6.06 | 5.87 | 21.91 | 11.61 | 10.30 | 5.17 | 36.16 | 11.06 | 3.02 | 22.13 | 19.37 |

s = single reduction d = double reduction t = triple reduction q = quadruple reduction qu = quintuple reduction

NOTE: Dimensions subject to change. Certified dimensions of ordered material furnished upon request.

Scoop

Shaft Mount

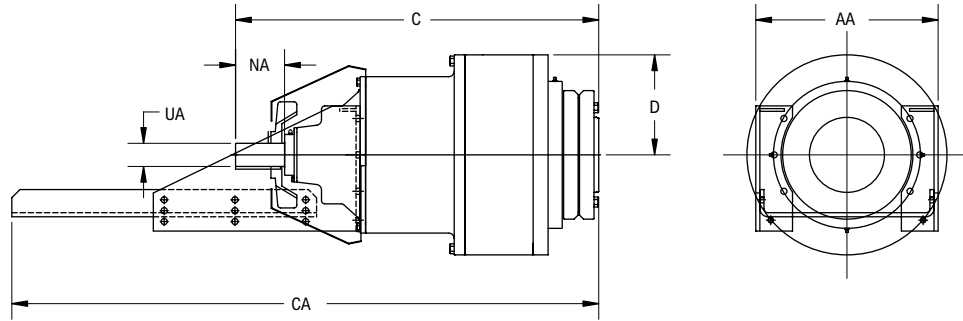

Dimensions (in)

| Series | Motor Range Size | C | | CA | | AA | | D Base to Centerline |
|----------|------------------|-------|-------|-------|-------|-------|-------|----------------------|
| | | d,t,q | qu | d,t,q | qu | d,t,q | qu | |
| Orion | 143T-256T | 33.36 | 34.98 | 53.92 | 55.14 | 16.75 | 15.25 | 9.19 |
| | 284T-326T | 33.36 | 34.98 | 58.92 | 58.14 | 19.00 | 17.00 | |
| Titan | 143T-286T | 40.49 | 39.88 | 63.33 | 60.03 | 23.00 | 15.25 | 11.06 |
| | 324T-326T | 40.49 | 39.88 | 66.33 | 63.03 | 23.00 | 17.00 | |
| Jupiter | 143T-286T | 47.30 | 49.93 | 72.82 | 72.76 | 27.25 | 23.00 | 12.00 |
| | 324T-326T | 47.30 | 49.93 | 75.82 | 75.76 | 27.25 | 23.00 | |
| Gemini | 143T-286T | 53.38 | 56.01 | 78.90 | 78.85 | 27.25 | 23.00 | 13.88 |
| | 324T-326T | 53.38 | 56.01 | 81.90 | 81.85 | 27.25 | 23.00 | |
| Hercules | 143T-326T | 65.75 | 65.75 | 91.00 | 91.00 | 27.25 | 27.25 | 17.75 |
| | 364T-365T | 65.75 | 65.75 | 94.00 | 94.00 | 27.25 | 27.25 | |

| Series | NA | | | | UA ▲ | | Key | | Avg. Wt. (lb) |
|----------|---------|------|---------|------|---------|-------|-------------------|-------------------|---------------|
| | w/o Fan | | w/Fan | | d, t, q | qu | d, t, q | qu | |
| | d, t, q | qu | d, t, q | qu | | | | | |
| Orion | 4.50 | 4.25 | 3.25 | 2.88 | 2.125 | 1.875 | 1/2 x 1/2 x 4 | 1/2 x 1/2 x 3-3/4 | 950 |
| Titan | 5.68 | 4.25 | 3.56 | 2.88 | 2.50 | 1.875 | 5/8 x 5/8 x 5-1/8 | 1/2 x 1/2 x 3-3/4 | 1,825 |
| Jupiter | 6.50 | 5.68 | 4.11 | 3.56 | 2.50 | 2.50 | 5/8 x 5/8 x 6 | 5/8 x 5/8 x 5-1/8 | 2,600 |
| Gemini | 6.50 | 5.68 | 4.11 | 3.56 | 2.50 | 2.50 | 5/8 x 5/8 x 6 | 5/8 x 5/8 x 5-1/8 | 4,853 |
| Hercules | 6.50 | 6.50 | 4.38 | 4.38 | 3.00 | 3.00 | 3/4 x 3/4 x 5-7/8 | 3/4 x 3/4 x 5-7/8 | 6,850 |

s = single reduction d = double reduction t = triple reduction q = quadruple reduction qu = quintuple reduction

NOTE: Dimensions subject to change. Certified dimensions of ordered material furnished upon request.

Installation and Maintenance Information

NOTE: The following instructions apply to all standard horizontally mounted Planetgear speed reducers. To assure long life and performance of Planetgear speed reducers, the following practices should be followed.

Nameplate

Planetgear SMP[™] Speed Reducers

REXNORD INDUSTRIES, LLC
WWW.REXNORD.COM

REXNORD

REDUCER ONLY

MOTOR HP

DATE

APPROX. U.S. GAL

MAX. TORQUE OUT LB. IN.

SERVICE HP

SERVICE CLASS

OIL CAP.

ORION

| OUTPUT RPM | AMBIENT TEMPERATURES | | | |
|--------------|-----------------------------|------|-----------------------------|------|
| | 15F TO 60F (-10C TO 16C) | | 50F TO 125F (10C TO 52C) | |
| | EQ-WG | AGMA | EQ-WG | AGMA |
| BELOW 10 | 150 EP | 4 EP | 320 EP | 6 EP |
| 10 AND ABOVE | 150 EP | 4 EP | 150 EP | 3 EP |

TITAN THRU HERCULES

| OUTPUT RPM | AMBIENT TEMPERATURES | | | |
|--------------|-----------------------------|------|-----------------------------|------|
| | 15F TO 60F (-10C TO 16C) | | 50F TO 125F (10C TO 52C) | |
| | EQ-WG | AGMA | EQ-WG | AGMA |
| BELOW 10 | 220 | 5 | 320 | 6 |
| 10 AND ABOVE | 100 | 3 | 150 | 4 |

IMPORTANT:
FILL TO THE LEVEL INDICATED WITH A PREMIUM QUALITY INDUSTRIAL TYPE PETROLEUM BASED GEAR LUBRICANT CONTAINING OXIDATION, RUST AND FOAM INHIBITORS. ORION SMP UNITS REQUIRE EXTREME PRESSURE LUBRICANT (SULFUR- PHOSPHORUS TYPE). FOR DETAILED LUBRICATION INSTRUCTIONS, SEE LUBRICATION BULLETIN.
UNDER NORMAL CONDITIONS, THE LUBRICANT SHOULD BE CHANGED EVERY 2500 HOURS OR EVERY SIX MONTHS WHICHEVER COMES FIRST.

P/N 1886026801

Operation of the reducer shall not differ from the application data warranted on the nameplate. Any change from this data requires submittal of new application information along with all nameplate data to the factory for engineering approval. All data changes require a new nameplate be issued and installed on the reducer. Note location of serial number and model number on the nameplate. When contacting the factory or sales representative, have the serial number and model number available as these unique numbers fully describe the reducer and allow for the fastest and most accurate exchange of information.

Spare and Repair Parts

When ordering parts, always give complete data from the nameplate on the Planetgear reducer. Model number and serial number information is necessary. Complete nameplate data will assure that you are receiving the correct parts. If a new nameplate is received with the new parts (as when a drive ratio is changed), replace the old nameplate on the drive with the new nameplate for future reference. Sun gears and carrier assemblies are stamped with a part number for easy identification.

Alignment

If reducer is received coupled to a motor, it has been aligned at the factory. However, because alignment may have been disturbed in shipment, it is best to check alignment and realign if necessary. The reliability and long life of the reducer requires careful installation of accessories and accurate alignment of the connecting shafts.

If the reducer is mounted onto a Planetgear baseplate and must be direct-coupled to a drive shaft, shimming should be done underneath the baseplate. Shim under the baseplate until the baseplate is level and all feet are on the same plane.

After first week — Check alignment of the total system and realign if necessary. Also tighten all bolts and plugs as required. Remember to remove the load from the system before attempting to service the reducer. This action reduces the possibility of unexpected motion in the system. Check coupling for alignment to make sure that settling or vibration has not caused excessive misalignment.

Coupling Alignment

Detailed instructions for installation of Rexnord Elastomer couplings are available from the factory, your Sales Engineer or local distributor. The following are general instructions:

- Correct for angular misalignment by measuring the distance from coupling hub (on motor shaft) to coupling hub (on reducer input shaft) at four places, each 90 degrees apart. Adjust or shim until the four readings are equal.
- Correct for parallel offset misalignment by placing a straight edge across the hub flange in two places, 90 degrees apart. Adjust or shim until the straight edge lays flat on both ends.
- Recheck for angular misalignment, adjust if necessary and tighten down the connected equipment.
- Install Elastomer center member elements. Tighten all cap screws to the correct torque value listed in the coupling installation sheet.

Face Mounted Scoops

The scoops have been designed to accommodate the motor weight and the starting torque based on the correct selections in this catalog and using standard 1750, 1430, 1170 and 950 AC motors. If a customer feels deflection is excessive, we suggest either placing a support under the end of the scoop, or drilling a hole in the end of the face scoop and installing a jack screw.

Pulley and Sheave Connections

Mount power takeoff as close as possible to the gear case in order to reduce the cantilever effect of overhung loads on the shaft bearings. If the power takeoff has only one hub, that hub should be on the outside with the plate closest to the seal cage of the reducer. Adjust belts to manufacturer specifications to prevent overtightening.

Installation and Maintenance Information

Gear Drive Lubrication

Read and carry out all instructions on the nameplate and review all warning tags. Determine minimum and maximum ambient temperatures the unit is to operate in. From the nameplate or the Ambient Temperature Table below, determine the proper AGMA or ISO grade lubricant for those temperature conditions and select an appropriate oil. SAE oils apply to gear lubricants only. Automotive oils are not recommended. All drives are splash-lubricated by gear rotation with even distribution to all gear meshes and bearings.

Determine specific oil quantity needed. **From the nameplate, determine the quantity of oil needed to operate the gear drive.**

Ambient Temperature – Speeds > 6 RPM Out

| Ambient Temp. | Viscosity @ 40°C Centistokes | AGMA Grade # | ISO Grade # |
|----------------------------|------------------------------|--------------|-------------|
| -10°C to 15°C 15°F to 60°F | 90 - 110 | 3 | 100 |
| 10°C to 50°C 50°F to 125°F | 135 - 165 | 4 | 150 |

Ambient Temperature – Speeds < 6 RPM Out

| Ambient Temp. | Viscosity @ 40°C Centistokes | AGMA Grade # | ISO Grade # |
|----------------------------|------------------------------|--------------|-------------|
| -10°C to 15°C 15°F to 60°F | 198 - 242 | 5 | 220 |
| 10°C to 50°C 50°F to 125°F | 288 - 352 | 6 | 320 |

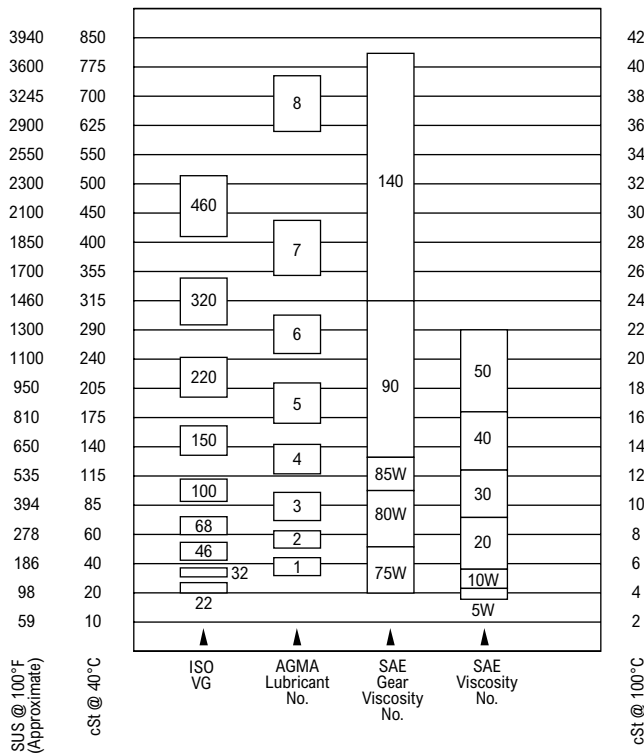

Petroleum Based R&O Gear Oils

Maximum operating temperature of lubricants: 200°F (93°C)
 AGMA 3: 15°F - 60°F AGMA 4: 50°F - 125°F

| Manufacturer | AGMA Viscosity Grade 3 Lubricant | AGMA Viscosity Grade 4 Lubricant |
|-------------------------|----------------------------------|----------------------------------|
| Amoco Oil Co. | American Ind. Oil #100 | American Ind. Oil #150 |
| Chevron U.S.A. Inc. | AW Machine Oil 100 | AW Machine Oil 150 |
| Cities Service Co. | Citgo Pacemaker 100 | Citgo Pacemaker 150 |
| Conoco Inc. | Dectol R&O Oil 100 | Dectol R&O Oil 150 |
| Exxon Company, U.S.A. | Teresstic 100 | Teresstic 150 |
| Gulf Oil Corp. | Harmony 100 | Harmony 150 D |
| Gulf Canada Limited | Harmony 66 | Harmony 77 |
| Imperial Oil Ltd. | Teresso 100 | Teresso 150 |
| Mobil Oil Corp. | DTE Heavy | DTE Extra Heavy |
| Phillips Petroleum Co. | Magnus Oil 100 | Magnus Oil 150 |
| Shell Oil Co. | Morlina 100 | Morlina 150 |
| Shell Canada Limited | Tellus 100 | Tellus 150 |
| Standard Oil Co. (Ohio) | Industron 66 | Industron 80 |
| Texaco Inc. | Regal Oil R&O 100 | Regal Oil R&O 150 |

| Manufacturer | AGMA Viscosity Grade 3 Lubricant | AGMA Viscosity Grade 4 Lubricant |
|--------------------------------|----------------------------------|----------------------------------|
| Texas Canada Inc. | Regal R&O 100 | Regal R&O 150 |
| Union Oil Co. of Calif. (East) | Unax RX 100 | Unax RX 150 |
| Union Oil Co. of Calif. (West) | Turbine Oil 100 | Turbine Oil 150 |

Maximum operating temperature of lubricants: 200°F (93°C)
 AGMA 5: 15°F - 60°F AGMA 6: 50°F - 125°F

| Manufacturer | AGMA Viscosity Grade 5 198-242 Lubricant | AGMA Viscosity Grade 6 288-352 Lubricant |
|-------------------------------|--|--|
| Amoco Oil Co. | Amer. Ind. Oil 220 | Amer. Ind. Oil 320 |
| BP Oil Co. | Energol HLP-HD 220 | ... |
| Chevron U.S.A., Inc. | Machine Oil AW 220 | Machine Oil AW 320 |
| Citgo Petroleum Corp. | Citgo Pacemaker 220 | Citgo Pacemaker 320 |
| Conoco Inc. | Dectol R&O Oil 220 | Dectol R&O Oil 320 |
| Exxon Company, U.S.A. | Teresstic 220 | Teresstic 320 |
| Houghton International, Inc. | hydro-Drive HP 1000 | ... |
| Imperial Oil Ltd. | Teresso 220 | Teresso 320 |
| Kendall Refining Co. | ... | ... |
| Keystone Lubricants | KLC-50 | ... |
| Lyondell Petrochemical (ARCO) | Duro 220 | Duro 32 |
| Mobil Oil Corp. | DTE Oil BB | DTE Oil AA |
| Pennzoil Products Company | Pennzbell AW Oil 220 | Pennzbell AW Oil 320 |
| Petro-Canada Products | Premium R&O Oil 220 | Premium R&O 320 |
| Phillips 66 Co. | Magnus Oil 220 | Magnus Oil 320 |
| Shell Oil Co. | Morlina 220 | Morlina 320 |
| Shell Canada Limited | Tellus 220 | Tellus 320 |
| Sun Oil Co. | Sunvis 9220 | ... |
| Texaco Lubricants | Regal Oil R&O 220 | Regal Oil R&O 320 |
| Unocal 76 (East) | Unax RX 220 | Unax AW 320 |
| Unocal 76 (West) | Turbine Oil 220 | Turbine Oil 320 |
| Valvoline Oil Co. | Valvoline AW ISO 220 | Valvoline AW ISO 320 |

Operating Temperature

If the speed reducer operates under extreme conditions or is exposed to large temperature fluctuations, the use of a synthetic oil is recommended. Contact lubrication supplier for recommendations.

NOTE: The synthetic lubricant should conform to the requirements of ANSI/AGMA 9005-D94.

If the speed reducer operates in an environment where the temperature fluctuations are predictable, choose an oil viscosity that is recommended for that given temperature (i.e. for cold weather operation, use an oil that will circulate freely at all times). The pour point of the oil should be 9°F (5°C) less than the minimum external temperature during reducer operation. During hot weather, use a higher viscosity oil that will not thin out and lose its lubricating qualities.

Special measures should be taken to protect drives operating in direct sunlight at ambient temperatures over 38°F (100°F). This protection can consist of a canopy over the drive or reflective paint on the drive.

If neither is possible, a heat exchanger or other cooling device may be required to prevent the reducer sump temperature from exceeding the allowable maximum oil temperature of 200°F (93°C).

Temperatures in excess of 120°F (49°C) feel hot to the human hand. Planetgear reducers can be operated with reducer sump oil temperatures of up to 200°F (93°C).

Oil Levels

Determine specific oil quantity needed. From the nameplate or the oil capacity chart, determine the quantity of oil in gallons needed to operate the reducer.

Lubrication Changes

For normal conditions, change oil every six months or 2,500 hours, whichever comes first. If operating under abnormal conditions such as high temperature, severe duty, moisture or particle contamination, oil may need to be changed more frequently. Reference Owners' Manual for maintenance.

Gear Drive Order Form

The following information is required when ordering a Planetgear speed gear drive:

Reducer Series:

- Orion Titan Jupiter Gemini Hercules

Hollow Bore Size: _____

Mounting Orientation:

- Horizontal
- Inclined
 - ____ Degrees High-Speed Shaft Up
 - ____ Degrees Low-Speed Shaft Up
- Vertical
 - High-Speed Shaft Up
 - Low-Speed Shaft Up
- Rotated
 - Degrees Clockwise Rotation (viewing Low Speed Shaft)
 - Degrees Counterclockwise Rotation (viewing Low Speed Shaft)

Rating Information:

Torque Rating: _____ Motor HP: _____
Input RPM: _____ Service Class/SF: _____
Ratio: _____
Output RPM: _____

Standard Reducers/Non-Motorized:

Basic Configuration

- Gear Drive Only
- Top Mount (Frame Size _____)
- Scoop Mount (Frame Size _____)
- C-Face (Frame Size _____)

Optional Accessories

- Couplings
- Coupling Guard
- Fan & Shroud
- Backstop (Rotation CW or CCW)
- Vertical Modification
- High Temperature Seals
- Extended Shafts
- Motor
- Double Torque Arm



866-REXNORD/866-739-6673 (Within the U.S.)
414-643-2366 (Outside the U.S.)
www.rexnord.com

Why Choose Rexnord?

When it comes to providing highly engineered products that improve productivity and efficiency for industrial applications worldwide, Rexnord is the most reliable in the industry. Commitment to customer satisfaction and superior value extend across every business function.

Delivering Lowest Total Cost of Ownership

The highest quality products are designed to help prevent equipment downtime and increase productivity and dependable operation.

Valuable Expertise

An extensive product offering is accompanied by global sales specialists, customer service and maintenance support teams, available anytime.

Solutions to Enhance Ease of Doing Business

Commitment to operational excellence ensures the right products at the right place at the right time.