

How to Use This Manual

This manual provides detailed instructions on installation and maintenance of parallel shaft Type DH, DV and right angle Type DB, DX gear drives. Use the table of contents below to locate required information.

CAREFULLY FOLLOW THE INSTRUCTIONS IN THIS MANUAL FOR OPTIMUM PERFORMANCE AND TROUBLE-FREE SERVICE OF YOUR FALK GEAR DRIVE.

Table of Contents

Installation Instructions	1-5
Shaft Connections	5
Tightening Torques	6
Lubrication Recommendations	6-9
Preventive Maintenance	9-10
Stored and Inactive Gear Drives	11

APPENDIX

Appendix A: Adjustable Torque Arm Installation	13
Appendix B: Rod End Adj. Torque Arm Installation	14-15
Appendix C: Swing Base Installation	16
Appendix D: Alignment Free Assembly & Installation	17-20
Appendix E: Electric Fan Installation & Maintenance	21-22
Appendix F: Cooling Tubes Installation & Maintenance	23-25
Appendix G: Thrust Plate & Fastener Usage	26
Appendix H: Directions For Inverting Drives DH2 & DB3	27

Introduction

Credit for long service and dependable operation of a gear drive is often given to the engineers who designed it, or the craftsmen who constructed it, or the sales engineer who recommended the type and size. Ultimate credit belongs to the mechanic on the job who worked to make the foundation rigid and level, who accurately aligned the shafts and carefully installed the accessories, and who made sure that the drive received regular lubrication. The details of this important job are the subject of this manual.

NAMEPLATE — Operate Falk gear drives only at power, speed and ratio shown on the nameplate. Before changing any one of these, submit complete nameplate data and new application conditions to the Factory for correct oil level, parts, and application approval.

DISASSEMBLY AND ASSEMBLY — Disassembly & assembly instructions and parts guides are available from the Factory or Rexnord representatives. When requesting information, please give complete data from the nameplate on the gear drive: model, M.O. number, date, rpm, and ratio.

WARNING: Consult applicable local and national safety codes for proper guarding of rotating members. Lock out power source and remove all external loads from drive before servicing drive or accessories.

Warranty

Rexnord Industries, LLC (the "Company") warrants that Drive One gear drives (I) conform to Company's published specifications, and (II) are free from defects of material for three years from the date of shipment.

Company does not warrant any non-Company branded products or components (manufacturer's warranty applies) or any defects in, damage to, or failure of products caused by: (I) dynamic vibrations imposed by the drive system in which such products are installed unless the nature of such vibrations has been defined and accepted in writing by Company as a condition of operation; (II) failure to provide suitable installation environment; (III) use for purposes other

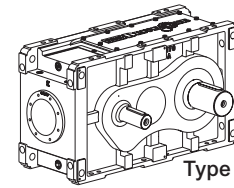

Type DH

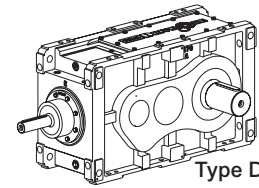

Type DB

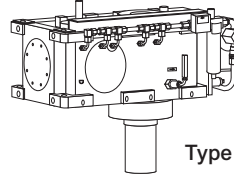

Type DV

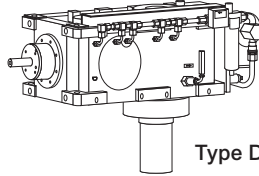

Type DX

than those for which designed, or other abuse or misuse; (IV) unauthorized attachments, modifications or disassembly, or (V) mishandling during shipping.

Installation Instructions

The following instructions apply to standard Falk Type DH, DB, DV & DX drives. If a drive is furnished with special features, refer to the supplementary instructions shipped with the drive.

WELDING — Do not weld on the gear drive or accessories without prior approval from the Factory. Welding on the drive may cause distortion of the housing or damage to the bearings and gear teeth. Welding without prior approval could void the warranty.

NOTE: Drives equipped with cooling fans may require removal of shroud when installing foundation fasteners.

EFFECTS OF SOLAR ENERGY — If the gear drive operates in the sun at ambient temperatures over 38°C (100°F), then special measures should be taken to protect the drive from solar energy. This protection can consist of a canopy over the drive or reflective paint on the drive. If neither is possible, a heat exchanger or other cooling device may be required to prevent the sump temperature from exceeding the allowable maximum.

MOUNTING POSITION — Standard mounting positions for types DH & DB are with the input and output shafts horizontal and for DV & DX with the output shafts vertical

Allowable mounting angles for standard oil levels are:

	Bridge	Slope
DH & DB	0° Up & 4° Down	± 1.5°

Consult the Factory for other angles.

If a gear drive is ordered for non-standard mounting positions, refer to the instructions provided with the drive for oil levels and bearing lubrication. If it is necessary to mount the gear drive in a different position from which it was ordered, refer to the Factory for required changes to provide proper lubrication.

FOUNDATION, GENERAL — To facilitate oil drainage, elevate the gear drive foundation above the surrounding floor level. If desired, replace the drive oil drain plug with a valve, but provide a guard to protect the valve from accidental opening or breakage.

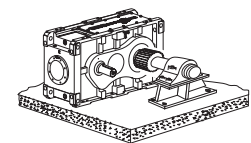

When an outboard bearing is used, mount drive and outboard bearing on a continuous foundation or bedplate, and dowel both in place.

FOUNDATION, STEEL — When mounting gear drive on structural steel, it is recommended that an engineered design be utilized for a pedestal, adapter base or bed to provide sufficient rigidity, to prevent induced loads from distorting the housing and causing gear misalignment. In the absence of an engineered design, it is recommended that a base plate, with thickness equal to or greater than the thickness of the drive feet, be securely bolted to steel supports and extend under the entire drive as illustrated.

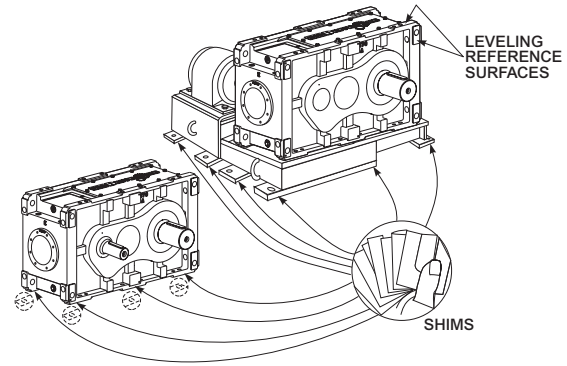
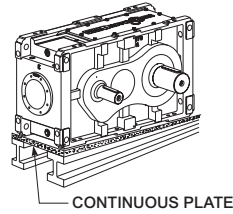

FOUNDATION, CONCRETE — If a concrete foundation is used, allow the concrete to set firmly before bolting down the gear drive. For the best type of mounting, grout structural steel mounting pads into the mounting base, as illustrated, rather than grouting the drive directly into the concrete.

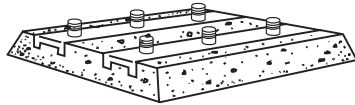

Motors and other components mounted on motor plates or motor brackets may become misaligned during shipment. ALWAYS check alignment after installation. Refer to page 5 for coupling alignment instructions.

Gear Drive Alignment

FOOT-MOUNTED DRIVES – Align drive with driven equipment by placing broad, flat shims under all mounting pads. Jack screw holes are provided by mounting feet to facilitate alignment. See Table 12, page 10 for fastener and wrench sizes. Start at the low-speed shaft end and level across the length and then the width of the drive. Check with a feeler gauge to make certain that all pads are supported to prevent distortion of housing when drive is bolted down. After drive is aligned with driven equipment and bolted down, align prime mover to drive input shaft. Refer to page 5 for coupling alignment.

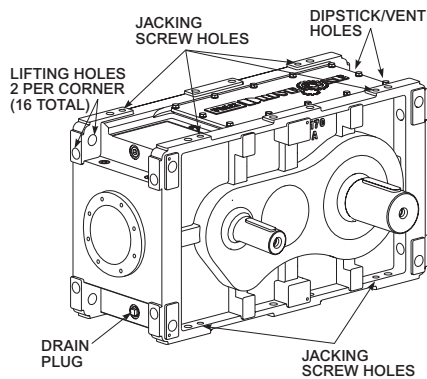

If equipment is received from the Factory mounted on a bedplate, the components were accurately aligned at the Factory with the bedplate mounted on a large, flat assembly plate. Shim under the bedplate foot pads until the gear drive is level and all feet are in the same plane.

Check high-speed shaft coupling alignment. If the coupling is misaligned, the bedplate is shimmed incorrectly. Re-shim bedplate and recheck high-speed coupling alignment. If necessary, realign motor.

Shaft-Mounted Drives – General

Shaft-mounted drives should never be mounted in a manner that restricts the natural movement of the drive. They should be allowed to move freely with the shaft on which it is mounted. Shaft-mounted drives should always be used in conjunction with a torque reaction arm. Refer to Appendixes A, B or C for torque reaction arm mounting instructions and angular limits. The drive may require repositioning on the driven shaft after initial installation to accommodate the location of the foundation anchor and be within limits specified in Appendix A (fixed torque arm) or Appendix B (adjustable torque arm).

The tapered bore hollow shaft is designed for use with a TA Taper® bushing for mounting the drive on a driven shaft with a straight outside diameter. The taper bushing assembly is supplied with a thrust plate kit and retention fastener as standard (usage is optional, shaft cover must be removed to install thrust plate kit). Refer to data sheet supplied with the tapered bushing assembly for driven shaft length, shaft keyway length and driven shaft tapped hole dimensions if the thrust plate kit with retention fastener is to be used.

Prior to installing the drive, it is a good idea to check the driven shaft for proper dimensions. Using Table 1 or 1A, find the driven shaft size for the application. Verify that dimensions A and B are within the allowable range. When dimensions are verified, proceed with the installation. The minimum and maximum driven shaft engagements, dimension N in Figure 1, are shown in Table 2. The minimum engagement is necessary for full bushing engagement, and the maximum (and specified) engagement is provided for use when the thrust plate kit is used for added retention capacity and an auxiliary removal aid (bushing nut normally used for both).

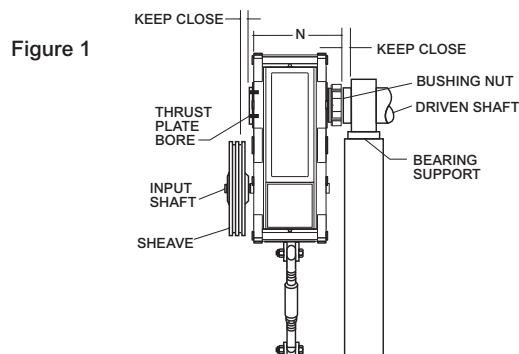
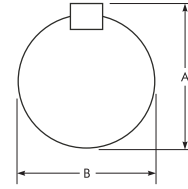

Table 1 — Driven Shaft Dimensions – mm

Drive Size	Shaft Diameter Tolerance h10			A		B	
	Nominal	+	-	Min	Max	Min	Max
M1130	90	0.0	0.140	99.314	99.774	89.860	90.000
	85	0.0	0.140	96.814	97.274	84.860	85.000
	80	0.0	0.120	94.334	94.774	79.880	80.000
	75	0.0	0.120	91.834	92.274	74.880	75.000
M1140	100	0.0	0.140	114.362	114.812	99.860	100.000
	95	0.0	0.140	111.862	112.312	94.860	95.000
	90	0.0	0.140	96.550	97.000	89.860	90.000
M1150	120	0.0	0.140	134.334	134.784	119.860	120.000
	115	0.0	0.140	131.834	132.284	114.860	115.000
	110	0.0	0.140	129.334	129.784	109.860	110.000
M1160	135	0.0	0.160	146.674	147.264	134.840	135.000
	130	0.0	0.160	144.314	144.784	129.840	130.000
	125	0.0	0.160	141.814	142.284	124.840	125.000
	120	0.0	0.160	139.334	139.784	119.860	120.000
M1170	150	0.0	0.160	164.193	164.773	149.840	150.000
	140	0.0	0.160	159.193	159.773	139.840	140.000
	130	0.0	0.160	154.293	154.773	129.840	130.000
M1180	170	0.0	0.160	184.173	184.763	169.840	170.000
	160	0.0	0.160	179.113	179.733	159.840	160.000
	150	0.0	0.160	174.113	174.733	149.840	150.000
M1190	185	0.0	0.160	201.698	202.303	184.815	185.000
	175	0.0	0.160	196.723	197.303	174.840	175.000
	170	0.0	0.160	194.223	194.803	169.840	170.000
	160	0.0	0.160	189.223	189.803	159.840	160.000
M1200	200	0.0	0.185	226.087	226.732	199.815	200.000
	190	0.0	0.185	221.087	221.732	189.815	190.000
M1210	200	0.0	0.185	226.087	226.732	199.815	200.000
	190	0.0	0.185	221.087	221.732	189.815	190.000

Table 2 — N Dimension †

Drive Size	Minimum mm (Inches)	Maximum mm (Inches)
M1130	285 (11.2)	340 (13.4)
M1140	300 (11.8)	390 (15.4)
M1150	310 (12.2)	410 (15.7)
M1160	330 (13.0)	450 (17.7)
M1170	340 (13.4)	435 (17.1)
M1180	380 (15.0)	515 (20.3)
M1190	395 (15.6)	545 (21.5)
M1200	423 (16.78)	425 (16.84)
M1210	423 (16.78)	425 (16.84)

† The minimum engagement is necessary for full bushing engagement; the maximum engagement is only if a thrust plate will be employed to remove the drive from the driven shaft. Shaft engagements include 5 mm (.20 inch) clearance at the bushing nut.

TAPER BUSHING — With the driven shaft keyway at the 12 o'clock position, slide bushing assembly onto the driven shaft, nut end first, and position the keyway slot over the shaft keyway. The bushing may have to be opened slightly to assist in installation. Insert a screwdriver into the slot in the bushing and very lightly pry open until the bushing slides onto the shaft. Insert the drive key furnished with the bushing into the shaft keyway. On drives using the thrust plate kit, slide the bushing assembly onto the driven shaft until final position (end of driven shaft open ended keyway).

Installation of Shaft-Mounted Drives Sizes M1130 - M1190

1. On drives using the thrust plate kit, remove the hollow low speed shaft cover. Before lifting the drive into position, rotate the high-speed shaft until the hollow shaft keyway will be in position to line-up with the driven shaft key.
2. Lift the drive into position and slide onto the driven shaft taking care that the driven shaft key seats into the hollow shaft keyway. DO NOT hammer or use excessive force.
3. Thread the bushing nut onto the hollow shaft one to two turns.

NOTE: The bushing nut threads have been coated with an anti-seize compound at the Factory. This compound should not be removed. Before re-installing a previously used nut, recoat the nut threads only with an anti-seize compound.

NOTE: In extremely severe or corrosive environments, additional anti-seize compound MUST be applied to the threads of the TA bushing nut.

WARNING: DO NOT apply anti-seize or lubricant to bushing or shaft surfaces. Use of anti-seize may prevent secure connection of the drive to the shaft and cause the drive to move.

See Table 12 for nut setscrew and wrench sizes.

- a. **PREFERRED METHOD** — Use a spanner, chain or pipe wrench to tighten the bushing nut to the

Table 1A — Driven Shaft Dimensions – Inches

Drive Size	Shaft Diameter Tolerance per AGMA 6109			A		B	
	Nominal	+	-	Min	Max	Min	Max
M1130	3.4375	0.0	0.006	3.8580	3.8770	3.4315	3.4375
	3.4875	0.0	0.006	3.7331	3.7521	3.1815	3.1875
	2.9375	0.0	0.006	3.6081	3.6271	2.9315	2.9375
M1140	4.1875	0.0	0.007	4.6278	4.6478	4.1805	4.1875
	3.9375	0.0	0.006	4.5028	4.5218	3.9315	3.9375
	3.4375	0.0	0.006	4.2528	4.2718	3.4315	3.4375
M1150	4.4375	0.0	0.007	5.1450	5.1650	4.4305	4.4375
	4.1875	0.0	0.007	5.0200	5.0400	4.1805	4.1875
	3.9375	0.0	0.006	4.8950	4.9140	3.9315	3.9375
M1160	4.9375	0.0	0.007	5.5920	5.6120	4.9305	4.9375
	4.4375	0.0	0.007	5.3420	5.3620	4.4305	4.4375
M1170	5.9375	0.0	0.007	6.4855	6.5055	5.9305	5.9375
	5.4375	0.0	0.007	6.2349	6.2549	5.4305	5.4375
	4.9375	0.0	0.007	5.9856	6.0056	4.9305	4.9375
M1180	6.5000	0.0	0.008	7.1590	7.1800	6.4920	6.5000
	6.0000	0.0	0.007	6.9106	6.9306	5.9930	6.0000
	5.9375	0.0	0.007	6.8794	6.8994	5.9305	5.9375
M1190	7.0000	0.0	0.008	7.8045	7.8255	6.9920	7.0000
	6.9375	0.0	0.008	7.7725	7.7935	6.9295	6.9375
	6.5000	0.0	0.008	7.5539	7.5749	6.4920	6.5000
	6.0000	0.0	0.007	7.3055	7.3255	5.9930	6.0000
	5.9375	0.0	0.007	7.2743	7.2943	5.9305	5.9375
M1200	8.000	0.0	0.008	9.2224	9.2434	7.9920	8.0000
	7.500	0.0	0.008	8.8478	8.8688	7.4920	7.5000
M1210	8.000	0.0	0.008	9.2224	9.2434	7.9920	8.0000
	7.500	0.0	0.008	8.8478	8.8688	7.4920	7.5000

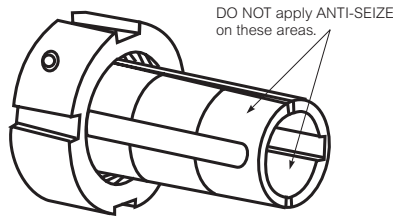

Table 3 — Wrench Type and Bushing Nut Tightening Torque

Drive Size	Wrenches		Nut Tightening Torque Nm (lb-ft)
	GearWrench	Williams	
M1130	81858	474B	380 (280)
M1140	81858	474B	450 (332)
M1150	81858	474B	450 (332)
	Ridgid Tool	Williams	
M1160	92685★	CT-15★	520 (384)
M1170	92685★	CT-15★	630 (465)
M1180	92685★	CT-15★	770 (568)
M1190	92685★	CT-15★	900 (664)

★ These are chain wrenches where standard spanner wrenches are not available.

Table 3A — Equivalent Tightening Torque ‡

Drive Size	Required Torque Nm (lb-ft)	Person's Weight kg (lbs)	Length of Handle mm (ft)
M1130	380 (280)	80-100 (180-220)	460-610 (1.5-2)
M1140	450 (332)	80-100 (180-220)	610-915 (2-3)
M1150	450 (332)	80-100 (180-220)	610-915 (2-3)
M1160	520 (384)	80-100 (180-220)	610-915 (2-3)
M1170	630 (465)	80-100 (180-220)	915-1220 (3-4)
M1180	770 (568)	80-100 (180-220)	915-1220 (3-4)
M1190	900 (664)	80-100 (180-220)	1220-1525 (4-5)

‡ If a torque wrench is not available, the torque can be approximated by applying the given weight at the given distance from the nut.

torque value indicated in Table 3. If the required torque cannot be measured, an approximation can be made using Table 3A. The full weight should be applied to the wrench handle in a horizontal position. For example, to achieve the required tightening torque for an M1180 bushing nut a 85 kg person would have to apply all of his/her weight to a wrench handle 950 mm from the nut, (a 190 lb. person would have to apply all his/her weight to a wrench handle 3 feet from the nut). Apply Loctite® 243 or equivalent to threads of the setscrew. Tighten the setscrew to 10 Nm (90 lb-in). For drives subjected to vibratory conditions, refer to Step c.

- b. **OPTIONAL TA BUSHING NUT TIGHTENING** — When the required tightening torque of the TA bushing nut can not be measured at the low-speed shaft, the torque-multiplying characteristic of the drive can be utilized. Rotating the high-speed shaft of the drive while holding the TA bushing nut stationary will allow a large torque to be reached. Fix the TA bushing nut by securing a spanner, chain or pipe wrench to the nut. Allow the wrench to contact a surface that will hold the force when tightening.

WARNING: Make sure the wrench will not slip and cause damage or injury.

Determine the proper rotation of the high-speed shaft to achieve tightening of the stationary nut. If the drive is equipped with a backstop, verify that the backstop will allow the necessary rotation, or remove the backstop. Find the torque to apply to the

high-speed shaft by dividing the tightening torque indicated in Table 3 by the drive's ratio (Torque ÷ Ratio). Apply the calculated torque to the high-speed shaft or coupling using a spanner, chain or pipe wrench. Be careful not to damage the usable length of the high-speed shaft. Remove the fixed wrench from the TA bushing nut and reassemble the backstop if necessary.

WARNING: Never use the prime mover to produce the required torque. This could result in severe personal injury or damage.

Apply Loctite 243 or equivalent to threads of setscrew. Tighten the setscrew to 10 Nm (90 lb-in) on the bushing nut. For drives subjected to vibratory conditions refer to Step c.

- c. **DRIVES SUBJECTED TO VIBRATORY CONDITIONS** — Extra precautions should be taken for drives subjected to vibratory conditions. With the nut of the TA bushing tightened to the specified torque, locate the setscrew hole in the nut of the bushing assembly. Using a 6 mm (15/64 inch) diameter drill, create a dimple in the outside diameter of the bushing flange by drilling through the setscrew hole in the nut. Apply Loctite 243 or equivalent to threads of setscrew and tighten into bushing nut.
- d. **DRIVES USING THRUST PLATE KIT** — Install thrust plate and thrust plate retaining ring in hollow shaft. Coat four to five engaging threads of retention fastener with Loctite 222 or equivalent (low-strength) thread locking compound and thread into driven shaft end until snug tight. Reinstall shaft cover.

Removal of Shaft-Mounted Drives Sizes M1130 - M1190

WARNING: Lock out power source and remove all external loads from drive before servicing drive or accessories.

1. Drain the lubricant from the drive.
2. Remove safety guards and belts (if so equipped). Remove hollow shaft cover if thrust plate kit is used.
3. Remove motor and motor mount (if so equipped).
4. Remove backstop (if so equipped).
WARNING: Drive must be supported during removal process. Use a sling and take up the slack before proceeding.
5. Remove the setscrew(s) on the bushing nut, which is located at the output end of the hollow shaft. On drives using the thrust plate kit, remove the driven shaft retention fastener.
6. Use a spanner, pipe or chain wrench to loosen the bushing nut. Initially the nut will freely rotate counterclockwise approximately 180° as the nut moves from the locked position to the removal position. At this point, anticipate resistance which indicates unseating of the bushing. Continue to rotate the nut until it is free from the hollow shaft. If unable to release the drive from the driven shaft with the bushing nut, the thrust plate kit using a backing bolt (threaded into the driven shaft tapped hole) and removal bolt (threaded into the thrust plate tapped hole) may be used to release the drive from the driven shaft. Refer to Appendix G for backing and removal bolt sizes (user supplied). To use, remove

thrust plate retaining ring and thrust plate, install backing bolt, and reinstall thrust plate with retaining ring. Remove bushing nut retaining ring. Install removal bolt in thrust plate and tighten against backing bolt to release drive from driven shaft (insert screwdriver in thrust plate key slot to engage hollow shaft keyway to prevent thrust plate rotation while tightening removal bolt).

7. Prepare drive for lifting by disconnecting the torque arm.
8. Slide the drive from the bushing. The bushing can be left in place or removed as required. If bushing will not slide off the shaft, insert a small prybar into the split of the bushing and pry the split open slightly to loosen the bushing and remove from the shaft.

Bushing Size	Removal Bolt Size & Minimum Length	Max Tightening Torque Nm (lb-ft)	Backing Bolt Size & Max Length
190-200 mm 7.50-8.00 inch	M30 x 3.5 x 200 mm 1.500-6UNC x 7.50 inch	1355 (1000) 1125 (830)	M24 x 3 x 45 mm 1.250-7UNC x 3.00 inch

Taper Bushing – Sizes M1200 & M1210

Driven shafts are retained on M1200 & M1210 drives with a thrust plate and three cap screw arrangement. With the driven shaft keyway at the 12 o'clock position, slide bushing onto the driven shaft, flange end first, and position the keyway slot over the shaft keyway. The bushing may have to be opened slightly to assist in installation. Insert a screwdriver into the slot in the bushing and very lightly pry open until the bushing slides onto the shaft. Insert the drive key furnished with the bushing into the shaft keyway.

Installation of Shaft-Mounted Drives Sizes M1200 M1210

1. Before lifting the drive into position, rotate the high-speed shaft until the hollow shaft keyway will be in position to line-up with the driven shaft key.
2. Lift the drive into position and slide onto the drive shaft taking care that the driven shaft key seats into the hollow shaft keyway. **DO NOT** hammer or use excessive force.
3. Align three holes in hollow shaft thrust plate with tapped holes in end of driven shaft. Insert fasteners through thrust plate and engage tapped holes in driven shaft one to two turns by hand to ensure that fasteners are not cross-threaded.
4. Tighten fasteners to the torque vales ($\pm 10\%$) listed below:
M24 x 3 – 640 Nm (470 lb-ft) for metric-based bushing bores.
1.250-7UNC – 1400 Nm (1060 lb-ft) for inch-based bushing bores.
5. Re-install low-speed shaft cover.

Removal of Shaft-Mounted Drives Sizes M1200 & M1210

1. Remove low-speed shaft cover.
2. Remove three thrust plate fasteners, retaining ring and thrust plate from the hollow shaft.
3. Select the backing bolts from the table above and install them into the three threaded holes in the end of the driven shaft. The head of the backing bolts provides a working surface for the removal bolts.
4. Re-insert the thrust plate and retaining ring into the hollow shaft and select the removal bolts from the table above.

5. Thread three removal bolts into the thrust plate until they contact the backing bolt heads.
6. Tighten the removal bolts equally in stages to the torque indicated in the table above. After torquing the bolts, as instructed, strike the bolts sharply with a hammer and re-torque the bolts if separation of the drive from the driven shaft did not occur. Repeat this procedure, re-torquing the bolts after each blow, until separation occurs.
7. Prepare drive for lifting by disconnecting the torque arm.
8. Slide the drive from the bushing. The bushing can be left in place or removed as required. If bushing will not slide off the shaft, insert a small prybar into the split of the bushing and pry the split open slightly to loosen the bushing and remove from the shaft.

Shaft Connections

WARNING: Provide suitable guards in accordance with local and national standards.

COUPLING CONNECTIONS — The performance and life of any coupling depends largely upon how well the coupling is installed and serviced. Refer to the coupling manufacturer's manual for specific instructions.

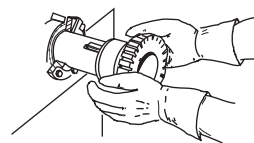

CORRECT METHOD

Heat interference-fitted hubs, pinions, sprockets or pulleys to a maximum of 135°C (275°F) and slide onto gear drive shaft.

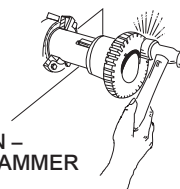

INCORRECT METHOD

DO NOT drive coupling hub, pinion, sprocket or pulley onto the shaft. An endwise blow on the shaft/coupling may damage gears and bearings.

– CAUTION –
DO NOT HAMMER

FALK COUPLINGS — (Except fluid type) Detailed installation manuals are available from the Factory, your local Rexnord representative or distributor — just provide size and type designations stamped on the coupling. For lubricant requirements and a list of typical lubricants meeting Rexnord specifications, refer to appropriate coupling service manual.

FALK FLANGED TYPE RIGID COUPLINGS — These are typically used on drives with vertical output shafts. The low-speed shaft extension ends of the solid vertical shaft drives are drilled and tapped to accommodate coupling keeper plates. Tightening torques for fastener, including keeper plate fasteners are listed in Table 4, page 6.

FALK FLUID COUPLINGS — Refer to the installation manual furnished with the Falk fluid coupling for installation and startup instructions. For Alignment-Free drives, refer to Appendix D.

GAP AND ANGULAR ALIGNMENT — If possible, after mounting coupling hubs, position the driving and driven equipment so that the distance between shaft ends is equal to the coupling gap. Align the shafts by placing a spacer block, equal in thickness to required gap, between hub faces, as shown at right, and also at 90° intervals around the hub. Check with feelers.

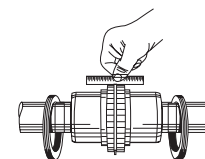

Steeflex® Illustrated

OFFSET ALIGNMENT — Align driving and driven shafts so that a straight edge will rest squarely on both couplings hubs as shown to the right and also at 90° intervals. Tighten foundation bolts of the connected equipment and recheck alignment and gap.

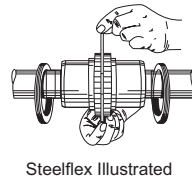

SPROCKETS, PULLEYS OR SHEAVES — Mount power take-offs as close to the gear drive housing as possible to avoid undue bearing load and shaft deflection.

Align the output shaft of the gear drive square and parallel with the driven shaft by placing a straightedge across the face of the sprockets or sheaves as illustrated.

Check horizontal shaft alignment by placing one leg of a square against the face of the sheave or sprocket with the spirit level on the horizontal leg of the square.

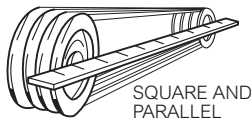
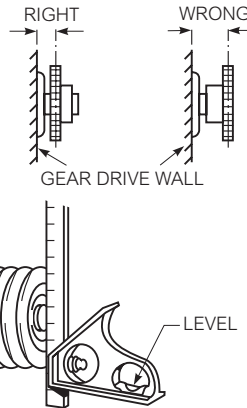

DO NOT over tighten belts or chains. Adjust chains to manufacturers' specifications. Adjust belts as follows:

The ideal tension is the lowest tension at which the belt will not slip under peak load conditions. Check the belt tension frequently during the first 24 to 48 hours of run-in operation. Over tightening belts shortens belt and bearing life. Keep belts free from foreign material which may cause slippage. Inspect the V-belt periodically; tighten the belts if they are slipping.

OUTBOARD BEARING — Mount the outboard bearing and gear drive on a common foundation so that they will shift as an assembly if settling should occur. Bring the outboard bearing to the correct horizontal position with broad flat shims under the mounting pad. Align accurately so that the load is equally divided between the two drive bearings and the outboard bearing. Mount a stop bar against the pillow block foot on the load side when large horizontal load components are exerted on the pillow block.

PINION MOUNTING — Mount pinion as close to the drive as possible to avoid undue bearing load and shaft deflection. Refer to the Factory for pinion alignment instructions.

NON FALK COUPLINGS — Refer to manufacturers' installation and maintenance instructions.

BACKSTOPS — To prevent damage to backstops due to incorrect motor shaft rotation at start up, couplings are NOT assembled when gear drives are furnished with backstops.

After completing electrical connections, check motor and gear drive shaft rotations. If rotations are correct, complete alignment and assembly of coupling.

Fastener Tightening Torques

Use the tightening torque values specified in Table 4 for fastening Falk gear drives, motors and accessories to their mounting surfaces with un-lubricated fasteners. DO NOT use these values for "torque locking" fasteners or for fastening components with aluminum feet or soft gaskets or vibration dampeners on the mounting surface. If the tightening torque exceeds the capacity of the torque wrench, use a torque multiplier. Use ISO property class 8.8 for metric fasteners. See Table 12 for fastener and wrench size.

Table 4 — Tightening Torques: ±5%

DO NOT Lubricate Fasteners

Fastener Size	Metric Fasteners – Property Class 8.8			
	Metal to Metal		Metal to Concrete	
	Nm	lb-ft	Nm	lb-ft
M4 x .7	3	2	2	1.5
M5 x .8	6	5	5	3.5
M6 x 1.0	10	8	8	6
M8 x 1.25	24	18	19	14
M10 x 1.5	50	36	39	29
M12 x 1.75	84	62	68	50
M16 x 2	210	156	170	126
M20 x 2.5	415	305	330	246
M24 x 3	705	530	570	420
M30 x 3.5	1 440	1060	1 150	850
M36 x 4	2 520	1860	2 030	1500
M42 x 4.5	4 050	3000	3 250	2400
M48 x 5	6 100	4500	4 880	3600
M56 x 5.5	9 850	7300	7 860	5800

Water Cooling

WATER COOLED HEAT EXCHANGERS — Install a shut-off or control valve in the water line to the heat exchanger to regulate the water flow through the exchanger. Also install a water flow gauge between the control valve and the exchanger to determine actual flow rate. Discharge water to an OPEN DRAIN to prevent back pressure.

INTERNAL COOLING TUBES — Refer to Appendix E for installation, operation, and maintenance of internal cooling tubes.

Lubrication Systems

SPLASH LUBRICATED DRIVES — Standard horizontal shaft type DH & DB drives are splash lubricated. The lubricant is picked up by the revolving elements and distributed to the bearings and gear meshes.

OIL PUMP LUBRICATED DRIVES — Types DV and DX are equipped with an external oil pump to provide oil to the upper bearings and gear meshes. The system is composed of an electric motor-driven gear pump and an internal distribution network with relief valve (set at 30 psi). The pump system may be furnished with a 50 or 60Hz, 3-phase electrical motors based on the selection. Refer to the pump motor nameplate and Table 5 for electrical requirements. Wire the motor for correct rotation as indicated by the rotation arrow. Optional accessories include an oil filter and flow indicator with switch. The flow indicator has a single pole, double throw switch rated at 15A, 125V/7A, 250V maximum. Connect the flow indicator switch with the prime mover control circuitry to prevent drive operation without the lubrication system.

Other types of gear drives may also be equipped with oil pumps for special lubrication considerations or external cooling.

Table 5 — Oil Pump Electrical Specifications

Drive Size	M1130 Thru M1210	
	Power	1.12 kw
Cycles, Hz	50	60
RPM	1425	1750
Voltage	220/380/440	208/230/460

Table 6 — Viscosity Grade Recommendations for Petroleum – Based R & O or EP Lubricants

Output RPM	Normal Climates			
	-9° to +16°C (15° to 60°F)		10° to 52°C (50° to 125°F)	
	ISO-VG	AGMA	ISO-VG	AGMA
Output RPM Below 80	150	4	320	6
Output RPM 80 & Above	150	4	220	5

Lubrication Recommendations

Carefully follow lubrication instructions on the gear drive nameplate, warning tags, and installation manuals furnished with the gear drive.

Lubricants listed in this manual are typical ONLY and should not be construed as exclusive recommendations. Industrial type petroleum based rust and oxidation inhibited (R & O) gear lubricants or industrial type sulfur-phosphorus extreme pressure (EP) gear lubricants are the recommended lubricants for ambient temperatures of -9°C to +50°C (15°F to 125°F).

For drives operating outside the above temperature range, refer to “Synthetic Lubricants” paragraphs. Synthetic lubricants can also be used in normal climates.

Table 8 — Extreme Pressure Lubricants †

 (Maximum Operating Temperature
93°C(200°F)

Manufacturer	Lubricant
Amoco Oil Co. BP Oil Co. Chevron U.S.A. Inc. Citgo Petroleum Corp.	Permagear/Amogear EP Energear EP Gear Compounds EP Citgo EP Compound
Conoco Inc. Exxon Co. U.S.A. E.F. Houghton & Co. Imperial Oil Ltd.	Gear Oil Spartan EP MP Gear Oil Spartan EP
Kendall Refining Co. Keystone Div. Pennwalt Corp. Lyondell Petrochemical (ARCO) Mobil Oil Corp. Petro-Canada Products	Kendall NS-MP Keygear Pennant NL Mobilgear Ultima EP
Phillips 66 Co. Shell Oil Co. Shell Canada Limited Sun Oil Co. Texaco Lubricants	Philgear Omala Oil Omala Oil Sunep Meropa
Valvoline Oil Co.	AGMA EP

† Minimum viscosity index of 90.

VISCOSITY (IMPORTANT) — The proper grade for R & O and EP lubricants is found in Table 7. For cold climate conditions refer to Table 9, page 8 and the “Synthetic Lubricant” paragraphs.

If a gear drive operates in a typical indoor environment where the ambient temperature is within 21°C to 52°C (70°F to 125°F), the oil viscosity could be increased one AGMA grade above that shown for the 10°C to 52°C (50°F to 125°F) range. That is, an AGMA Number 6 or 7 could be substituted for a 5 or 6 respectively, under these ambient conditions.

Table 7 — Petroleum Based R & O Gear Oils † Maximum operating temperature of lubricants 93°C (200°F)

AGMA Viscosity Grade	4	5	6	7
ISO Viscosity Grade	150	220	320	460
Viscosity SSU @ 100°F	626-765	918-1122	1335-1632	1919-2346
Viscosity cSt @ 40°C	135-165	198-242	288-352	414-506
Manufacturer	Lubricant	Lubricant	Lubricant	Lubricant
Amoco Oil Co. BP Oil Co. Chevron U.S.A., Inc. Citgo Petroleum Corp.	Amer.Ind. Oil 150 Machine Oil AW 150 Citgo Pacemaker 150	Amer.Ind. Oil 220 Energol HLP-HD 220 Machine Oil AW 220 Citgo Pacemaker 220	Amer. Ind. Oil 320 Machine Oil AW 320 Citgo Pacemaker 320	Amer. Ind. Oil 460 Citgo Pacemaker 460
Conoco Inc. Exxon Company, U.S.A. Houghton International, Inc. Imperial Oil Ltd.	Dectol R&O Oil 150 Teresstic 150 Hydro-Drive HP 750 Teresso 150	Dectol R&O Oil 220 Teresstic 220 Hydro-Drive HP 1000 Teresso 220	Dectol R&O Oil 320 Teresstic 320 Teresso 320	Dectol R&O Oil 460 Teresstic 460
Kendall Refining Co. Keystone Lubricants Lyondell Petrochemical (ARCO) Mobil Oil Corp. Pennzoil Products company Petro-Canada Products	Four Seasons AW 150 KLC-40 Duro 150 DTE Oil Extra Heavy Pennzbell AW Oil 150 Premium R & O 150 KLC-50 Duro 220 DTE Oil BB Pennzbell AW Oil 220 Premium R & O 220 Duro 32 DTE Oil AA Pennzbell AW Oil 320 Premium R & O 320 DTE Oil HH Pennzbell AW Oil 460
Phillips 66 Co. Shell Oil Co. Shell Canada Limited Sun Oil Co. Texaco Lubricants	Magnus Oil 150 Morlina 150 Tellus 150 Sunvis 9150 Regal Oil R&O 150	Magnus Oil 220 Morlina 220 Tellus 220 Sunvis 9220 Regal Oil R&O 220	Magnus Oil 320 Morlina 320 Tellus 320 Regal Oil R&O 320 Morlina 460 Regal Oil R&O 460
Unocal 76 (East) Unocal 76 (West) Valvoline Oil Co	Unax RX 150 Turbine Oil 150 Valvoline AW ISO 150	Unax RX 220 Turbine Oil 220 Valvoline AW ISO 220	Unax AW 320 Turbine Oil 320 Valvoline AW ISO 320	Turbine Oil 460 Turbine Oil 460

† Minimum viscosity index of 90.

Table 9 — Viscosity Grade Recommendations for Synthetic Lubricants *

Output RPM	Cold Climates				Normal Climates					
	-34° to -12°C (-30° to +10°F)		-26° to +10°C (-15° to +50°F)		-18° to +27°C (0° to +80°F)		-12° to +52°C (+10° to +125°F)		-7° to +52°C (+20° to +125°F)	
	ISO-VG	AGMA	ISO-VG	AGMA	ISO-VG	AGMA	ISO-VG	AGMA	ISO-VG	AGMA
Below 80	32	0S	68	2S	150	4S	320	6S	320	6S
80 & Above	32	0S	68	2S	150	4S	220	5S	320	6S

* Refer to the Factory for viscosity recommendations when ambient temperatures are below -34°C (-30°F) or above 52°C (125°F).

OIL PUMPS — When selecting a lubricant for a gear drive equipped with an oil pump, cold temperature oil viscosity is important. Lubricant viscosity at start-up generally should not exceed 1725 cSt (8,000 SSU). When exceeding this viscosity, pump cavitation is possible, reducing oil circulation and possibly damaging the pump. A sump heater may be required or it may be possible to use a lower viscosity oil to minimize pump cavitation. Refer to the Factory.

Petroleum-Based Lubricants

R & O GEAR LUBRICANTS (Table 7) — Industrial type petroleum-based rust and oxidation inhibited (R & O) gear lubricants are the most common and readily available general purpose gear lubricants.

EP LUBRICANTS (Table 8) — For highly loaded gear drives or drives loaded in excess of original estimates, industrial-type petroleum EP lubricants are preferred. The EP lubricants currently recommended are of the sulfur-phosphorus type.

WARNING: EP LUBRICANTS IN FOOD PROCESSING INDUSTRY — EP lubricants may contain toxic substances and should not be used in the food processing industry without the lubricant manufacturers' approval. Lubricants which meet USDA "H1" classification are suitable for food processing applications.

Table 10 — Synthetic Lubricants – Polyalphaolefin Type *

AGMA Viscosity Grade	0S	2S	4S	5S	6S	7S
ISO Viscosity Grade	32	68	150	220	320	460
Viscosity cSt @ 40°C	28.8-35.2	61.2-74.8	135-165	198-242	288-352	414-506
Viscosity SSU @ 100°F	134-164	284-347	626-765	918-1122	1335-1632	1919-2346
Manufacturer	Lubricant					
Chevron U.S.A., Inc.	Clarity Synthetic PM Oil 220
Conoco, Inc.	Syncon R & O 32	Syncon R & O 68	...	Syncon R & O 220 †	...	Syncon R & O 460 †
Dryden Oil Co.	Drydene SHL Lubricant 32	Drydene SHL Lubricant 68	Drydene SHL Lubricant 150	Drydene SHL Lubricant 220	Drydene SHL Lubricant 320	Drydene SHL Lubricant 460
Exxon Co. U.S.A.	Teresstic SHP 32	Teresstic SHP 68	Teresstic SHP 150	Teresstic SHP 220	Teresstic SHP 320	Teresstic SHP 460
Mobil Oil Corp.	SHC 624	SHC 626	SHC 629	SHC 630	SHC 632	SHC 634
Pennzior Products Co.	Pennzgear SHD 32	Pennzgear SHD 68	Pennzgear SHD 150	Pennzgear SHD 220	Pennzgear SHD 320	Pennzgear SHD 460
Petro-Canada Products	Super Gear Fluid 150EP †	Super Gear Fluid 220EP †	Super Gear Fluid 320EP †	Super Gear Fluid 460EP †
Phillips 66 Company	Syndustrial P Oil 32
Shell Oil Co.	Hyperia 220	Hyperia 320	Hyperia 460
Sun Co.	Hyperia S 220 †	Hyperia S 320 †	Hyperia S 460 †
Texaco Lubricants Co.	Pinnacle 32	Pinnacle 68	Pinnacle 150	Pinnacle 220	Pinnacle 320	Pinnacle 460
Whitmore Mfg. Co.	Pinnacle EP 150 †	Pinnacle EP 220 †	...	Pinnacle EP 460 †
76 Lubricants Company	Decathlon 4EP †	Decathlon 5EP †	Decathlon 6EP †	Decathlon 7EP †
	76 Triton Syngear 4EP †	76 Triton Syngear 5EP †	...	76 Triton Syngear 7EP †

* Minimum viscosity index of 130. Consult lubricant supplier/manufacturer for maximum operating temperature.

† Minimum viscosity index of 120.

‡ EP lubricant (contains sulphur phosphorus).

Table 11 — Greases for Bearings and Seals

-18° to +93°C (0° to 200°F)

Manufacturer	Lubricant
Amoco Oil Co. BP Oil Co. Chevron U.S.A., Inc. Citgo Petroleum Corp.	Amolith Grease No. 2 Energres LS-EP2 Industrial Grease Medium Premium Lithium Grease No. 2
Conoco Inc. Exxon Company, U.S.A. E.F. Houghton & Co. Imperial Oil Ltd.	EP Conolith Grease No. 2 Unirex N2 Cosmolube 2 Unirex N2L
Kendall Refining Co. Keystone Div. Pennwalt Corp. Lyondell Petrochemical (ARCO) Mobil Oil Corp. Mobil Oil Corp. Petro-Canada Products	Multi-Purpose Lithium Grease L421 Zeniplex 2 Litholine H EP 2 Grease Mobilith 22 Mobilith SHC 460 ★ Multipurpose EP2
Phillips 66 Co. Shell Oil Co. Shell Canada Limited Sun Oil Co. Texaco Lubricants	Philube Blue EP Alvania Grease 2 Alvania Grease 2 Ultra Prestige EP2 Premium RB Grease
Unocal 76 (East & West) Valvoline Oil Co.	Unoba EP2 Multilube Lithium EP Grease

★ High performance synthetic alternate.

CAUTION: LUBRICANTS & INTERNAL BACKSTOPS — Do not use lubricants with anti-wear additives or lubricant formulations including PTFE (Teflon), lead derivatives, graphite or molybdenum disulfide in drives equipped with backstops. Some lubricants in Table 8 may contain several of these additives.

Synthetic Lubricants

Synthetic lubricants of the polyalphaolefin type are recommended for cold climate operation, high temperature applications, extended temperature range (all season) operation, and/or extended lubricant change intervals. The proper viscosity grade of synthetic lubricant is given in Table 9. Refer to Table 10 for Synthetic lubricants.

WARNING: SYNTHETIC LUBRICANTS IN FOOD PROCESSING INDUSTRY — Synthetic lubricants may contain toxic substances and should not be used in the food processing industry without the lubricant manufacturers' approval. Lubricants which meet USDA "H1" classification are suitable for food processing applications.

Bearing and Seal Greases

All drives and some backstops have grease-lubricated seals. Some vertical shaft and specially mounted drives have grease-lubricated bearings. Drives are shipped with NLGI #2 grease in the seal housing cavities unless otherwise specified. Refer to Table 11 for grease recommendations.

GREASE-LUBRICATED BEARINGS — Vertical shaft drives with drywells have grease-lubricated lower low-speed bearings. These bearings are lubricated at the Factory with an NLGI#2 grease. Refer to the preventive maintenance instructions for greasing instructions.

GREASE-LUBRICATED SEALS — Drive One drives are furnished with grease purged seals which minimize the entry of contaminants into the drive. Drives are shipped with NLGI #2 grease in the seal housing cavities unless otherwise specified. If grease could contaminate the product, as in the food and drug industries, it should be removed. A grease that meets USDA "H1" classification is suitable for food processing applications.

Oil Levels

TYPES DH & DB — Fill the drive with oil to the level indicated on the oil dipstick. Approximate oil capacities are given on the drive nameplate.

The inspection cover is sealed with a non hardening chemical gasket eliminator. When replacing the inspection cover, run a bead of Loctite 515 Gasket Eliminator ★ (or equivalent) around the perimeter of the inspection opening, making sure to circle the fastener holes.

★ Product of Henkel Corp., Rocky Hill, CT.

DRIVES WITH OIL PUMPS — Types DV, DX, and occasionally other types of gear drives will be equipped with oil pumps for cooling or special lubrication considerations. If a drive is equipped with an oil pump, fill the drive to the level marked on the dipstick. Run the lubrication system for several minutes to fill the system components. Verify that the pump is circulating oil properly, then recheck oil level. If necessary, add oil to compensate for filter and/or cooler.

Before starting the gear drive, rotate the input shaft to check for obstructions. Then start the drive and allow it to run without load for several minutes. Shut down and recheck oil level. If everything is satisfactory, the drive is ready for operation.

Preventive Maintenance

AFTER FIRST WEEK — Check alignment of total system and realign where necessary. Also tighten all external bolts and plugs where necessary. DO NOT readjust the internal gear or bearing settings in the drive. These were permanently set at the Factory. See Table 12 for fastener and wrench sizes.

AFTER FIRST MONTH — Proceed as follows:

1. Operate drive until old sump oil reaches normal operating temperature. Shut down drive and drain immediately.
2. Immediately flush drive with an oil of the same type and viscosity grade as the original charge (warmed to approximately 38°C (100°F) in cold weather) by rapidly pouring or pumping a charge equal to 25 - 100% of the initial fill volume or until clean oil flows through the drain.
3. Close the drain and refill the drive to the correct level with new oil of the correct type and viscosity.

PERIODICALLY —

1. Check the oil level of the drive when it is stopped and at ambient temperature. Add oil if needed. If the oil level is ABOVE the high oil level mark on the dipstick, have the oil analyzed for water content. Moisture in the oil may indicate that a seal or the heat exchanger is leaking. If so, replace the defective part immediately and change the oil. DO NOT fill above the mark indicated as leakage or undue heating may result.
2. Check coupling alignment to make certain that foundation settling has not caused excessive misalignment.
3. If drive is equipped with a fan, periodically clean accumulated foreign matter from the fan, guard, and deflector.
4. If drive is equipped with a torque arm, check for free movement.

Table 12 — Fastener & Wrench Sizes

Fastener		DRIVE SIZE								
		M1130	M1140	M1150	M1160	M1170	M1180	M1190	M1200	M1210
Bushing Nut	Diameter	185mm 7.3"	205mm 8.1"	225mm 8.9"	240mm 9.4"	260mm 10.2"	280mm 11.0"	295mm 11.6"
	Circumference	581mm 22.9"	644mm 25.4"	709mm 27.9"	754mm 29.7"	817mm 32.2"	880mm 34.6"	927mm 36.5"
Bushing Nut Setscrew	Screw Size	M8	M8	M8	M8	M8	M8	M8
	Hex Size	4mm	4mm	4mm	4mm	4mm	4mm	4mm
Inspection Cover	Screw Size	M12	M12	M12	M12	M12	M12	M12	M12	M12
	Wrench Size	19mm	19mm	19mm	19mm	19mm	19mm	19mm	19mm	19mm
Jackscrews	Screw Size	M12	M16	M16	M20	M20	M24	M24	M24	M24
	Wrench Size	19mm	24mm	24mm	30mm	30mm	36mm	36mm	36mm	36mm
Magnetic Drain Plugs	Plug Size	3/4 BSPT	3/4 BSPT	3/4 BSPT	3/4 BSPT	1.0 BSPT	1.0 BSPT	1.0 BSPT	1.0 BSPT	1.0 BSPT
	Wrench Size	14mm	14mm	14mm	14mm	19mm	19mm	19mm	14mm	14mm
Other Plugs	Plug Size	3/4 BSPT	3/4 BSPT	3/4 BSPT	3/4 BSPT	1.0 BSPT	1.0 BSPT	1.0 BSPT	1.0 BSPT	1.0 BSPT
	Hex Size	12mm	12mm	12mm	12mm	17mm	17mm	17mm	17mm	17mm
Torque Arm	Nut Size	M30	M30	M36	M36	M36	M36	M48	M48	M48
	Wrench Size	46mm	46mm	55mm	55mm	55mm	55mm	75mm	75mm	75mm
Grease Purge Cover	Screw Size	M6/M8	M6/M8	M6/M8	M6/M8	M6/M8	M8	M8	M8	M8
	Wrench Size	10mm/13mm	10mm/13mm	10mm/13mm	10mm/13mm	10mm/13mm	13mm	13mm	13mm	13mm
Shaft Fan Shroud	Screw Size	M8	M8	M8	M8	M8	M8	M8	M12	M12
	Wrench Size	13mm	13mm	13mm	13mm	13mm	13mm	13mm	18mm	18mm
Shaft Fan Setscrew	Screw Size	M6/M8	M6/M8	M6/M8	M8	M8	M8	M8	M10	M10
	Hex Size	3mm/4mm	3mm/4mm	3mm/4mm	4mm	4mm	4mm	4mm	5mm	5mm

Lubricant Changes

OIL ANALYSIS REPORT — Checking oil condition at regular intervals is recommended. In the absence of more specific limits, the guidelines listed below may be used to indicate when to change oil:

1. Water content is greater than 500 ppm (0.05%).
2. Iron content exceeds 150 ppm.
3. Silicon (dust/dirt) exceeds 25 ppm.
4. Viscosity changes more than 15%.

PETROLEUM LUBRICANTS — For normal operating conditions, change gear oils every six months or 2500 operating hours, whichever occurs first. Change oil more frequently when gear drives operate in extremely humid, chemical or dust laden atmospheres. In these cases, R & O and EP lubricants should be changed every 3 to 4 months or 1500 to 2000 hours. If the drive is operated in an area where the temperatures vary with seasons, change oil viscosity grade to suit temperature. Lubricant suppliers can test oil periodically and recommend economical change intervals.

SYNTHETIC LUBRICANTS — Synthetic lube change intervals can be extended to 8000 - 10,000 hours depending upon operating temperatures and lubricant contamination. Change oil more frequently when gear drives operate in extremely humid, chemical or dust-laden atmospheres. In these cases, synthetic lubricants should be changed every 4 to 6 months or 4000 to 6000 hours. Laboratory analysis is recommended for optimum lubricant life and gear drive performance. Change lube with change in ambient temperature, if required. Refer to Table 9 for synthetic lubricant viscosity recommendations.

GREASE-LUBRICATED SEALS — Depending on the frequency and degree of contamination (at least every

six months or when changing oil in the drive), purge contaminated grease from seals by slowly pumping fresh grease, WITH A HAND GREASE GUN, through the seal cavity until fresh grease flows out along the shaft. Wipe off purged grease. Refer to Table 11 for NLGI #2 greases. Some of these greases are of the IP type and may contain toxic substances not allowed in the food processing industry. A grease that meets the USDA "H1" classification is suitable for food processing applications.

CAUTION: Rapid greasing with a power grease gun can force grease inward past the seals causing seal leaks.

GREASE LUBRICATED BEARINGS (TYPES DV AND DX)

— Most vertical low-speed shaft drives have a grease-lubricated lower low-speed bearing. Grease bearings during oil changes or at intervals of every 6 months or 2500 hours of operation whichever is less.

VERTICAL SHAFT DRIVES — Remove the pressure relief plug before greasing. Pump grease into bearing cage until fresh grease appears at the plug. Replace the pressure relief plug when finished. See figure below.

Refer to Table 11 for NLGI #2 greases. Some of these greases are of the EP type and may contain toxic substances not allowed in the food processing industry. A grease that meets the USDA "H1" classification is suitable for food processing applications.

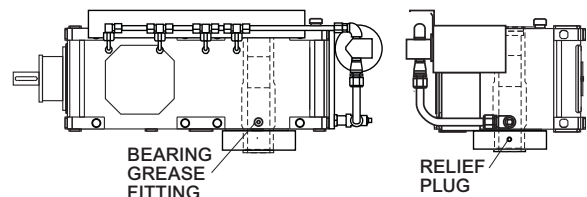

Stored & Inactive Gear Drives

Each gear drive is protected with a rust preventative that will protect parts against rust for a period of 4 months in an outdoor shelter or 12 months in a dry building after shipment from the Factory.

If a gear drive is to be stored, or is inactive after installation beyond the above periods, drain oil from housing and spray all internal parts with a rust preventative oil that is soluble in lubricating oil or add Motorstor™ vapor phase rust inhibitor at the rate of 1.05 liters per cubic meter (one ounce per cubic foot) of internal drive space (5% of sump capacity). Refer to Table 13 for Motorstor quantities. Rotate the shafts several times by hand. Before operating, drives which have been stored or inactive must be filled to the proper level with oil meeting the specifications given in this manual. Refer to Manual 128-014 for “Start-up after Storage” instructions.

Periodically inspect stored or inactive gear drives and spray or add rust inhibitor every six months, or more often if necessary. Indoor dry storage is recommended.

Gear drives ordered for extended storage can be treated at the Factory with a special preservative and sealed to rust-proof parts for periods longer than those cited previously.

The vented dipstick should be replaced with a plug (vented dipstick should be attached to gear drive for future use) so that the protective rust inhibiting atmosphere is sealed inside the drive. Install vented dipstick when preparing drive for operation.

Table 13 — Motorstor/VCI-10★

(Add to stored or inactive drives)

DRIVE SIZE	Motorstor	
	Milliliters Per Drive	Ounces Per Drive
M1130	45	1.5
M1140 & M1150	60	2
M1160 & M1170	120	4
M1180 & M1190	180	6
M1200 & M1210	235	10

★ Product of Daubert Chemical Company, Chicago, IL.



THIS PAGE INTENTIONALLY LEFT BLANK

Adjustable Torque Arm Installation

Introduction

The Drive One adjustable tie rod style torque arm is available for all shaft-mounted Drive One sizes, parallel shaft Type DH only. It is used to support the drive when mounted in a standard horizontal position. Refer to the Factory for other positions. The torque arm is mounted directly to the drive with an anchor bracket. The torque arm requires mounting holes in the driven equipment support structure to provide for clevis bracket attachment. The customer is responsible for determining the structural integrity of their support member.

Mounting

It is natural for the drive system to move during operation. This movement is due to run out from the driven equipment shaft and gear drive low-speed shaft. Clearance in the torque arm assembly will accommodate the motion of the drive. To allow for the movement, the torque arm should be centered at its attachment point on the drive system and also centered in the clevis bracket on the support member. Over-tightening or failure to center the torque arm in the mounting will restrict the drive's motion and will result in premature failure of the drive or driven equipment. The torque arm should be perpendicular to the support structure $\pm 2^\circ$ when looking at the end of the drive. See Figure 1.

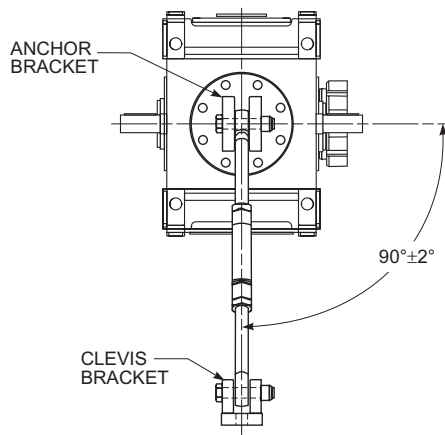

Figure 1

Installation

1. Position the drive on the driven equipment shaft such that the torque arm is perpendicular and centered in the clevis mounted to the supporting structure and at its attachment point on the drive system. Ideally, the clevis bracket should be added to the structure after the drive has been secured to the driven equipment.

NOTE: Do not fasten the torque to the support structure at this time.

2. Secure the drive to the driven equipment via the TA bushing or rigid coupling connection.
3. Check that the torque arm remains perpendicular and centered in the clevis if mounted. If the torque arm is not perpendicular and centered, reposition the drive on the driven equipment shaft. If the clevis bracket is not mounted, position and mount at this time.

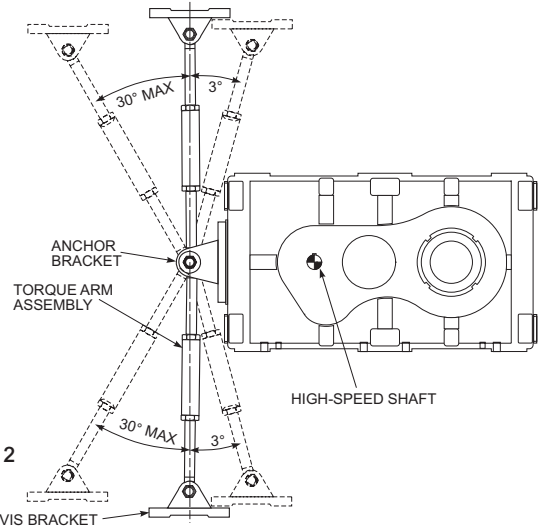

Figure 2

4. The exact position of the torque arm may vary within the range shown in Figure 2. For torque arm mountings other than shown, refer to the Factory. If it is necessary to shorten the torque arm assembly, cut the excess from either tie rod end on Sizes M1130 through M1190 only.

Table 1 — Load Reaction Through Tie Rod

Drive Size	Load ‡	
	N	lb
M1130	42700	9600
M1140	54500	12300
M1150	69500	15600
M1160	92300	20800
M1170	126000	25300
M1180	130000	29200
M1190	160200	36000
M1200	170300	38300
M1210	202900	45600

‡ Load includes moment due to motor and motor mount with torque arm at maximum angle.

5. The support to which the clevis bracket is mounted must sustain the load from the torque reaction shown in Table 1. The maximum load reaction through the torque arm occurs when the torque arm is located in the extreme off angle position. Use Class 8.8 fasteners to anchor the clevis bracket. Refer to Table 2 for fastener size and tightening torque.

Table 2 — Tie Rod Clevis Bracket Fastener Tightening Torque

Drive Size	Fastener Size †	Tightening Torque - Nm (lb-ft)	
		Steel Foundation	Concrete Foundation
M1130-M1140	M20 x 2.5	415 (305)	330 (246)
M1150-M1160	M24 x 3.0	705 (530)	570 (420)
M1170-M1210	M30 X 3.5	1440 (1060)	1150 (850)

† Class 8.8 fasteners required.

6. Bolt the torque arm to both the clevis bracket and the drive anchor bracket and tighten the bolts until seated against the brackets. DO NOT bend the bracket as clearance between the clevis brackets and tie rod is necessary.

Rod End Adjustable Torque Arm Installation

Introduction

The Drive One rod end type adjustable torque arm is available for all shaft-mounted Drive One sizes, both parallel shaft Type DH and right angle Type DB. It is used to support the drive when mounted in a standard horizontal position; other positions may be available (consult Factory). The torque arm accessory is suitable for use on swing bases, bedplates, or mounted directly to the drive. Three styles of rod end torque arms are available: (1) Standard style for swingbase or bedplate mounting, (2) Clevis style for mounting directly to the drive foot, (3) Turnbuckle style for greater length and adjustment. The torque arm requires mounting holes in the driven equipment support structure to provide for attachment. The customer is responsible for determining the structural integrity of their support member.

Mounting

It is natural for the drive system to move during operation. This movement is due to runout from the driven equipment shaft, gear drive low-speed shaft and the connection of the two. Rod ends containing plain spherical bearings form a link to provide a resilient mounting support that accommodates the motion of the drive. To allow for maximum movement, the torque arm must be perpendicular to the supports and rod ends centered in the mounting anchor bracket. Restricting the drive's motion in any way may result in premature failure of the drive or driven equipment.

Installation

1. Position the drive on the driven equipment shaft such that the torque arm link is centered in the anchor bracket. Ideally, the anchor bracket mounting holes should be added to the structure after the drive has been secured to the driven equipment.

NOTE: Do not fasten the torque arm to the support structure at this time.

2. Secure the drive to the driven equipment via the TA Bushing, shrink disc or rigid coupling connection.

3. Mount the anchor bracket or clevis to the drive or drive system if not already done. Locate the position of the anchor bracket to be mounted to the support structure. Match drill the mounting holes for M20 Cl. 8.8 or 0.75 inch Grade 5 fasteners or better. Lock washers and flat washers are also required.

NOTE: Torque arm must be vertical ($\pm 1^\circ$) in both directions after installation.

4. (IF REQUIRED) Assemble rod end components to create a link. A combination of male/female rod ends, clevis/male rod end or turnbuckle/male rod ends are required dependent on torque arm style. All styles require jam nuts to lock linkage. Refer to Figures 1 thru 3.

NOTE: Rod ends must be assembled such that the relative position of one rod end head to the other is parallel. Loosen locknut and adjust if necessary. See Figure 4.

5. For Standard and Turnbuckle style torque arm, install pin through one lug of anchor bracket mounted to drive. Position spacer, then rod end and finally second spacer on pin. Finish positioning pin within anchor bracket. Install retaining ring to secure the pin. See Figure 1 or 3. For Clevis style torque arm, install crowned pin through clevis and drive foot. Secure pin with retaining ring. See Figure 2.
6. Install pin in anchor bracket mounted to supporting structure with spacers in a similar manner. The drive may need to be rotated about the low-speed shaft to install second pin. If the drive has a backstop, it may be necessary to disconnect the backstop to rotate the drive. Refer to the backstop instructions for removal.
7. If the drive system is not horizontal, the rod end linkage can be adjusted (within the limits indicated in the catalog or certified print) to level the drive.
8. Verify the torque arm link is centered in the anchor bracket and is not restricting motion of the drive.
9. Some rod ends may be provided with grease fittings for lubricating. Grease rod end at every scheduled maintenance or at least every six months. See Table 11 for approved greases.

Figure 1

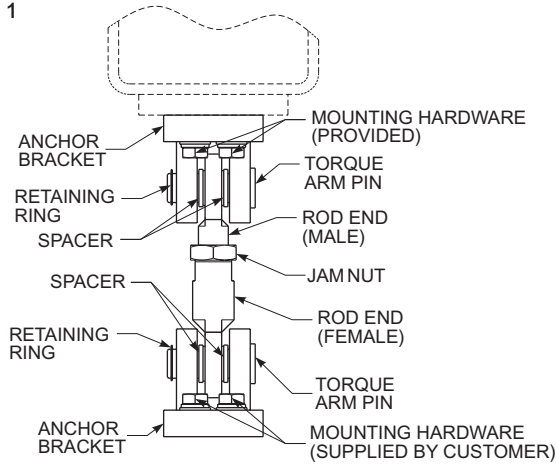

Figure 2

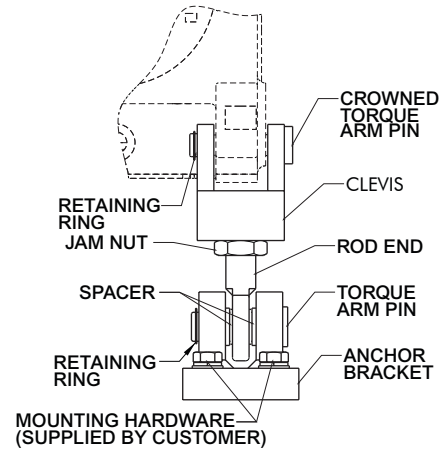

Figure 3

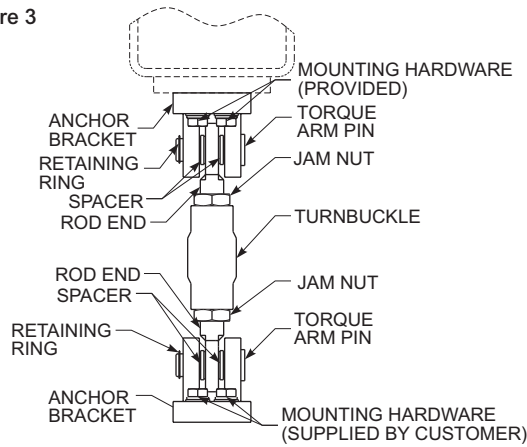
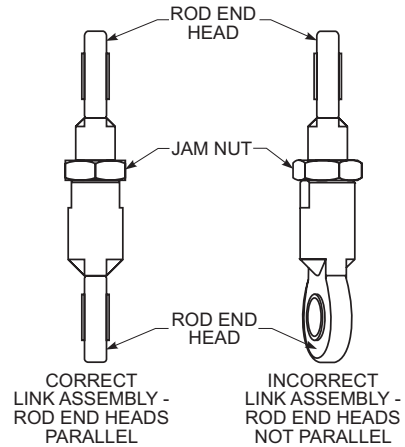

Figure 4



Swing Base Installation

Introduction

The Drive One Swing Base is a welded steel structure designed to support a motor and a right angle Type DB, shaft-mounted drive. The swing base itself is a length of square cross-sectional tubing with plates welded to it for the motor and drive. The motor and drive plates are not machined, and are supported by gussets for additional strength. A torque arm attaches to the tube section near the motor end of the swing base.

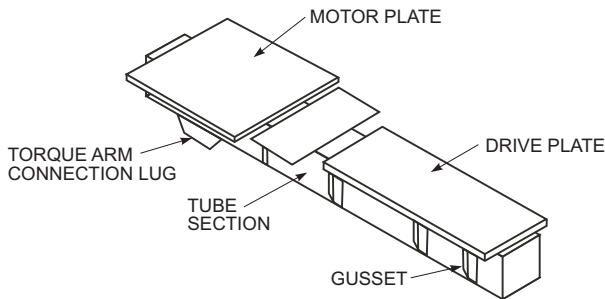

Supporting the Swing Base

The torque arm connection lug prevents the swing base from lying flat on the ground; therefore, a supporting structure is required for mounting the gear drive and motor to the swing base. This structure is typically built from wood and is unique to each swing base. All gussets have a 19 mm (0.75 inch) diameter hole for securing the swing base to the supporting structure.

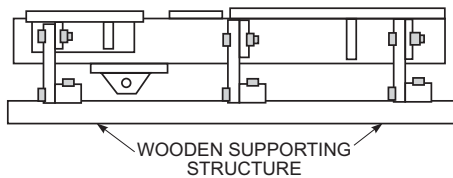

Mounting Gear Drive to Swing Base

It is Rexnord's standard procedure to mount the drive to the swing base at the Factory. These instructions are to be followed when field mounting of the drive to the swing base is required. Use of broad, flat shims between the gear drive and mounting plate are recommended to prevent distortion of the housing when the drive is bolted down. Jacking screw holes are provided in gear drive housing to aid in fixing the shims. Begin at the low-speed shaft end and level across the length and then the width of the gear drive. Use a feeler gauge to ensure that all pads are supported. Bolt down the drive to the torque specified in Table 4, page 6.

Mounting Motor and Coupling Alignment

Shims are provided for motor mounting. Holes must be drilled into the swing base motor plate for mounting of the motor. Step blocks are also provided for some small frame motors. Use a feeler gauge to ensure that all motor pads are firmly seated. Motor mounting needs to be done in conjunction with coupling alignment to control angular and offset misalignment. Refer to the coupling manufacturer's manual for specific instructions. Bolt down the motor to the torque specified in Table 4, page 6.

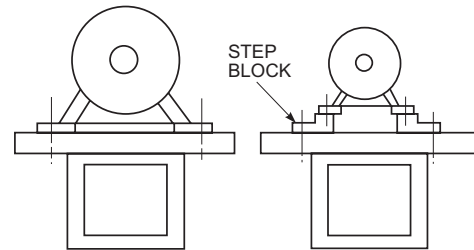

Coupling Guard

The coupling guard must be trimmed in order to fit the height and shaft extension requirements. Refer to the coupling guard installation manual for instructions on trimming the guard. After the guard has been trimmed, holes can be drilled in the coupling guard plate on the swing base. The guard can then be bolted down to the plate.

Lifting the Swing Base Assembly

After the drive, motor, and coupling have been mounted to the swing base, the completed assembly can be lifted into position for installation on the driven shaft. The motor eyebolt and the lifting holes on the drive housing can be used as cable attachment points. The motor eyebolt is strongest when the cable pull is vertical. To ensure that cable pull on the motor eyebolt is vertical, use of a spreader bar is recommended. See the sketch below. To ensure safety, chains or a sling should be placed behind the torque arm connection.

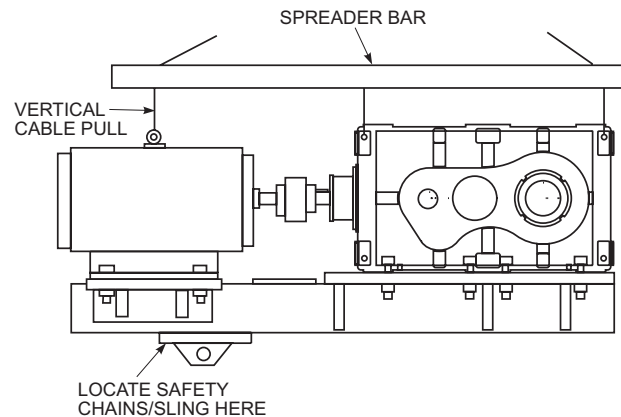

Mounting Swing Base Assembly to Driven Equipment

Mount the gear drive to the driven shaft (see page 3). Secure the torque arm to the foundation per the instructions in Appendix A.

Alignment-Free Assembly and Installation – Welded Design

Introduction

The Alignment-Free drive design consists of a shaft-mounted drive, bell housing, motor adapter plate, torque arm, motor and coupling. When assembled, the bell housing, motor adapter, and motor locate off registers, resulting in alignment of the motor and gear drive shafts. Therefore, no additional alignment is required for the high-speed coupling.

Assembly Instructions

The bell housing is fastened to the drive's high-speed end using cap screws through the four mounting holes on that face (see Table 1 for size and torque). The bell housing will locate on the bevel head of the drive. Read instructions provided with high-speed coupling prior to assembly.

Table 1 — Tightening Torques

Drive Size	Bolt Size	Tightening Torque	
		N-m	lb-ft
M1150	M24	725	535
M1160	M24	725	535
M1170	M30	1450	1070
M1180	M30	1450	1070
M1190	M36	2530	1866
M1200	M36	2530	1866
M1210	M36	2530	1866

Fluid Coupling

Location of the fluid coupling on the high-speed shaft of the drive is determined by the provided shaft spacer. Install the fluid coupling on the high-speed shaft of the gear drive per fluid coupling instructions. If a shaft fan is required, remove every other of the twelve delay fill chamber fasteners. Install the fan adapter ring to the fluid coupling using the long socket head cap screws provided. Place a mounting post between the delay fill chamber flange and the adapter ring as shown in Figure 1. After all fasteners and mounting posts are installed, tighten cap screws to the torque specified in Table 2. Install the six fan segments to the outer bolt circle of the adapter ring. See Table 2 for tightening torque.

Figure 1

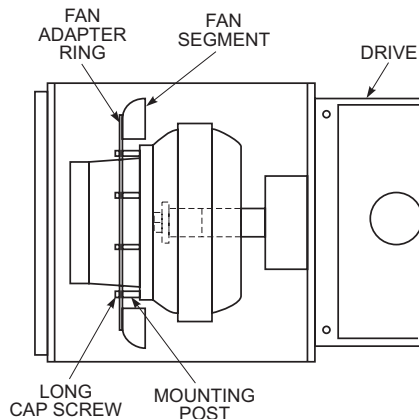

Once the fluid coupling is installed, the motor adapter plate can be mounted to the bell housing, also being located by a register. Measurements must be taken to accurately position the motor half of the coupling hub on the motor

Table 2 — Fan Mounting Tightening Torques

Fastener Location	Fastener Size	Tightening Torque	
		Nm	ft-lb
1420HFDD	M12	80	59
1480HFDD	M12	80	59
1584HFDD	M14	130	96
Fan Segment	M8	20	15
Fan Hub ‡	M6	10	7.5

‡ For close coupling only.

shaft. First, measure the distance from the motor mounting face to the end of the motor shaft (A). Then measure the distance from the motor adapter plate face to the hub on the fluid coupling (B). Finally measure the distance from the hub flange to the hub end (C). The desired gap can be found in Table 3, based on coupling size.

Table 3 — Coupling Gap

Fluid Coupling Size	Tschan Hub Size	Gap	
		mm	Inch
370HFDD	200	6.5	0.256
1420HFDD	230	7.5	0.295
1480HFDD	260	7.5	0.295
1584HFDD	300	8.4	0.331
1660HFDD	360	9.0	0.354

Calculate the hub protrusion:

$$\text{Protrusion} = (A + \text{Gap}) - (B + C)$$

If the calculated protrusion is a negative value, the hub overhangs the shaft by that amount (Figure 2).

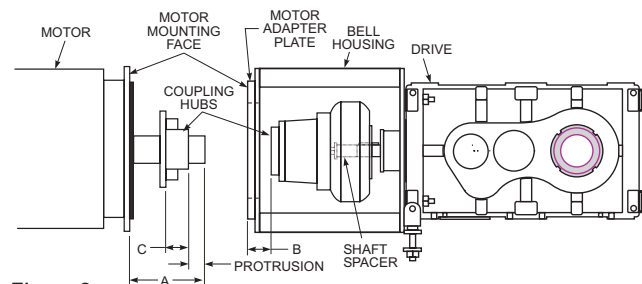

Figure 2

Once the hub is correctly located on the motor shaft, the motor can be mounted to the motor adapter plate. The hubs will be aligned and come together to the proper gap. To fill the fluid coupling to the proper oil level, align the mark on the perimeter of the fluid coupling with the mark in the center of the inspection window on the bell housing on the side opposite the TA bushing nut or shaft extension. To locate the correct mark on the fluid coupling, begin by aligning the fill hole of the fluid coupling with the mark in the inspection window. For fill angles less than 90°, rotate the fill plug upward until the marks line up. For fill angles greater than 90°, rotate the fill plug downward until the marks line up. When the proper marks are in line, fill the fluid coupling with recommended fluid until fluid appears at the lip of the fill hole.

Close Coupling

If the drive requires a shaft fan, mount the fan hub on the high-speed shaft of the gear drive. See Figure 3. See Table 4 for shaft protrusion based on drive size. Apply Loctite 242 or equivalent to hub setscrews and tighten into hub. Mount the fan adapter ring to the fan hub. Install six fan segments to the outer bolt circle on the adapter ring to complete the fan. See Table 2 for fastener tightening torque.

Figure 3

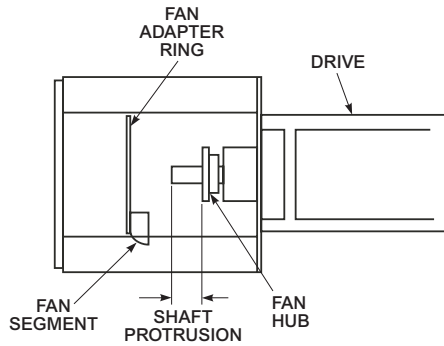

Table 4 — Fan Hub Location

Drive Size	Shaft Protrusion	
	mm	Inch
M1150	105	4.13
M1160	110	4.33
M1170	115	4.53
M1180	125	4.92
M1190	130	5.12
M1200	178	7.01
M1210	178	7.01

Mount the motor to the motor adapter plate on the bell housing before installing the coupling. Once the motor is secured, measure the distance (D) between the end of the motor shaft and the high-speed shaft of the drive. See Figure 4. Subtract the distance (D) from the length of the spacer coupling (BE). Then divide this value in half to find the overhang of each hub [Overhang + (BE - D)/2]. The overhang will be negative. This is the amount each hub overhangs the shaft. Once the overhang is determined, install the hubs according to the instructions provided with the coupling. Install the spacer sections and verify the gap is correct. If not, readjust the hub on the motor shaft. If the coupling is furnished with an interference fit, readjustment will not be possible. Take extra care in making measurements. After the proper gap is set, finish installing the coupling per the instructions.

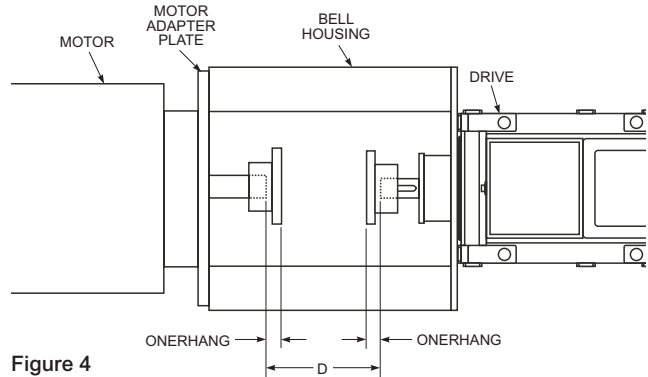

Figure 4

Lifting the Alignment Free Drive

Lifting points are provided on the corners of the motor side of the bell housing. See Figure 5. Lift by these and the provisions provided on the drive housing itself to maneuver the drive. DO NOT lift by the motor lifting eye.

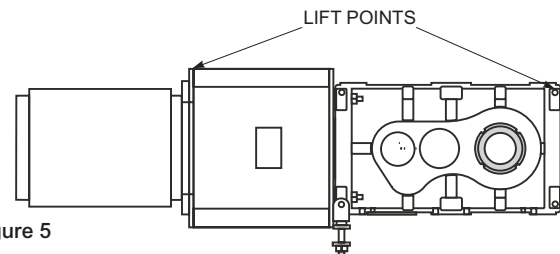

Figure 5

Mounting the Drive

Mount the Alignment-Free drive to the driven equipment per Page 3. The torque arm must be located on the TA bushing nut side (hollow shaft) or the extension side (solid shaft) of the drive at the foot as shown in Figure 6. Connect the torque arm to the foundation per the torque arm installation instructions.

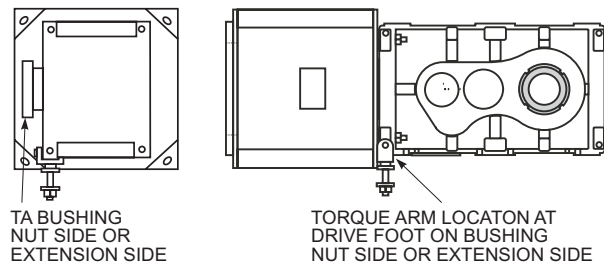

Figure 6

Alignment-Free Assembly and Installation – Cast Design

Introduction

The Alignment-Free drive design consists of a shaft-mounted gear drive, bell housing, torque arm, motor and coupling. When assembled, the gear drive, bell housing and motor locate off registers, resulting in alignment of the shafts. Therefore, no additional alignment is required for the high-speed coupling.

Assembly Instructions

The bell housing is fastened to the gear drive's high-speed end using capscrews through the four mounting holes on that face with a nut and lock washer (see Table 1 for size and torque). Apply Loctite #242 or equivalent to mounting fastener threads. The bell housing will locate on the bevel head of the gear drive. Read instructions provided with high-speed coupling prior to assembly.

Table 1 — Tightening Torques

Drive Size	Bolt Size	Tightening Torque	
		Nm	lb-ft
M1140	M24	780	570
M1150	M24	780	570
M1160	M24	780	570
M1170	M30	1540	1140
M1180	M30	1540	1140
M1190	M36	2720	2000
M1200	M36	2720	2000
M1210	M36	2720	2000

High-Speed Shaft Fan

High-speed shaft fan is standard on all Drive One Alignment-Free drives. Fan size and position is dependent on bell housing casting and high-speed coupling, not drive size. Assemble fan to fan hub, apply Loctite #242 or equivalent to fastener threads and tighten.

CAUTION: Do not over-tighten fasteners into plastic fan as fan may crack.

Mount the fan hub on the gear drive high-speed shaft such that the set screw hole in the hub is towards the end of the shaft. Locate the hub axially at the values listed in Table 2. Dimensions listed are from the inside face of the

Table 2 — Fan Hub Location

Coupling Size	Bell Housing Casting Number *	Hub Location	
		mm	inch
1420	D011723	130	5.12
1480	D011724	125	4.92
1584	D011725	115	4.53
1660	D011726	142	5.59
Spacer Coupling	D011723	130	5.12
Spacer Coupling	D011725	115	4.53

* Casting number located on inside sidewall of bell housing.

bell housing to the far side of the hub. See Figure 1. Apply Loctite #242 or equivalent to threads of the set screw and tighten over key to secure hub in position. Fan hub must be installed prior to installing high-speed coupling hub.

Assemble fan shroud mounting rails to bell housing. Assemble fan cowling with expanded metal guard to back of fan shroud/plates on same fasteners. Mount fan shroud assembly to mounting rails. The cowling may require

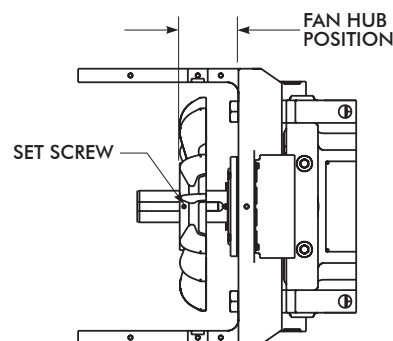

Figure 1

to be notched to allow clearance for the bell housing to drive mounting fasteners. Rotate fan to ensure clearance, and reposition fan hub if necessary. Split fan guard may be removed or installed without disrupting high-speed coupling. See Figure 2.

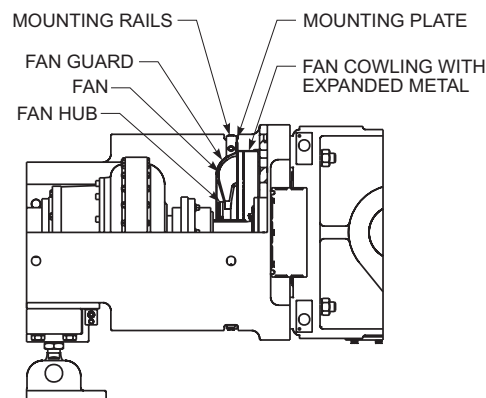

Figure 2

Fluid Coupling

The fluid coupling can be installed/removed without removing the motor (see fluid coupling instructions for procedure). Mount the coupling hubs to the drive high-speed shaft and the motor shaft. Hubs are to be mounted flush with the end of the shafts (coupling hubs may be furnished with an interference fit). Mount the motor to the bell housing, apply Loctite #242 or equivalent fastener threads and tighten to proper torque. Install fluid coupling per coupling instructions.

To fill the fluid coupling to the proper oil level, install the small top cover on the bell housing. Rotate the fluid coupling such that the fill hole is up and fill with the approximate quantity of oil (see coupling instructions for oil type and quantity). Rotate the coupling in either direction to align the mark on the perimeter of the fluid coupling with the mark in the center of the cover on the bell housing. A container should be placed to catch any excess oil that may spill from the fill hole. If oil drains from the fill hole, allow all excess to drain to achieve the proper fill level. If no oil drains when marks are aligned, rotate coupling back and add more oil. Repeat process until excess oil drains and proper fill level is achieved.

Close Coupling

Mount the coupling hubs to the drive high-speed shaft and motor shaft. Hubs are to be mounted flush with the end of the shafts unless otherwise noted (coupling hubs may be furnished with an interference fit). Mount the motor to the bell housing, apply Loctite #242 or equivalent to fastener threads and tighten to proper torque. Install high-speed coupling per coupling instructions.

Guards and Covers

Install bell housing covers (top and bottom). Install air deflectors on the top, bottom and both sides of the gear drive. The bends of the deflectors are perforated to allow positioning of the deflectors. Air deflectors should be positioned approximately 25 mm (1 inch) from the nearest housing surface by bending deflector towards or away from the drive.

Torque Arm

The carriage, adjusting rod, brackets and support bar are furnished pre-assembled from the Factory. Assemble the rod ends with heads perpendicular to each other (90°) as shown in Figure 3. Rod end threads must be engaged a minimum of one times thread diameter. Attach female rod end to carriage with pin. Place a spacer on each side of the rod end. Secure pin with locking plate. Carriage may be adjusted from center to either far end of the housing

to facilitate installation of pin. Ensure that adjusting rod locking plate is NOT installed at this time as it will prevent adjustment of the torque arm assembly. Assemble anchor bracket to male rod end with a spacer on each side and secure with pin and retaining ring.

Lifting the Alignment-Free Drive

Lifting points are provided on the corners of the motor end of the bell housing. See Figure 4. Lift by these and the provisions provided on the drive housing itself to maneuver the drive. DO NOT lift by the motor lifting eye.

Mounting the Drive

Mount the Alignment-Free drive to the driven equipment per Pages 2 and 3 of this manual. With Alignment-Free drive assembly supported, rotate adjusting screw to move torque arm to desired position and to line up with foundation. Torque Arm must be perpendicular in both directions ($\pm 1^\circ$). Adjust screw if not. Install locking plate to lock the adjusting screw (plate can be installed on either side). Remove support from drive and secure anchor bracket to foundation. Use M24 Class 8.8 (1 inch Grade 5) or better fasteners with lock and flat washers to mount anchor bracket. Slots are provided such that torque arm can be mounted perpendicular.

CAUTION: Do NOT adjust torque arm screw after support is removed and torque arm is under any load.

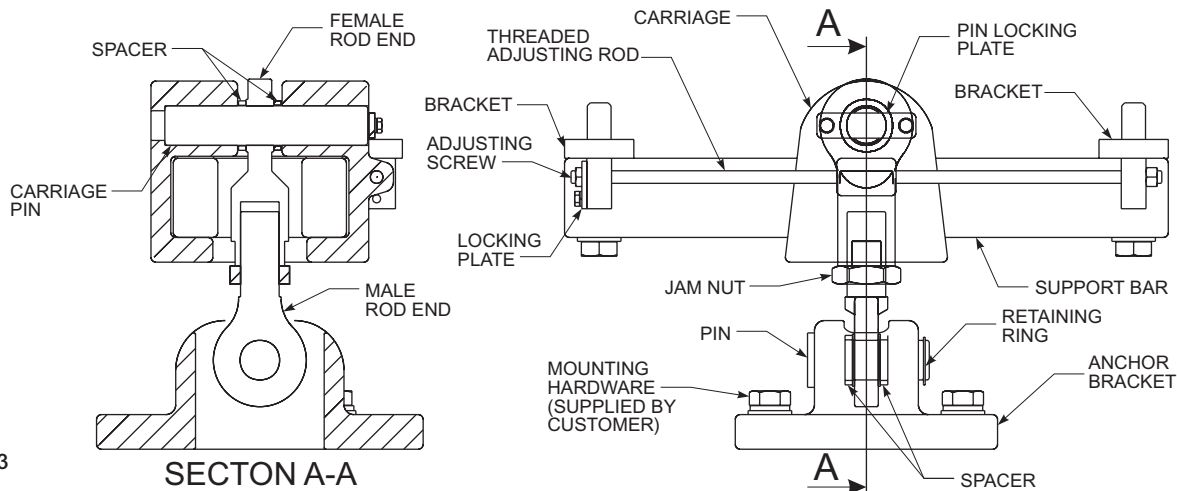

Figure 3

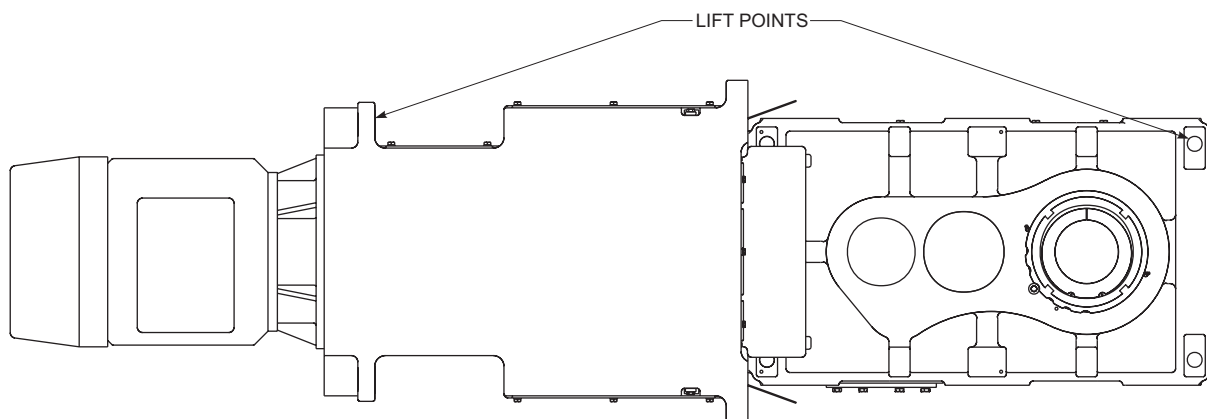

Figure 4

Electric Fan Installation & Maintenance

Installation

The installation and troubleshooting of electric cooling fans are to be carried out by a qualified electrician according to the applicable local, state, province and federal codes. Inspect for any damage that may have occurred during transit. Check all bolts, screws, set screws, etc. Retighten as required. Before installing, rotate the blade to be sure it does not rub. Adjust if necessary. Before installation, read the entire manual carefully.

This guide is pertinent only to electric fans furnished by the Factory and manufactured by Multifan Inc. (can be verified from nameplate on the electric fan). In the event the electric fan furnished by the Factory is of a special nature (manufactured by an alternate fan manufacturer), please contact the Factory for appropriate electric fan installation and maintenance instructions.

General Safety Information

Warning: To reduce the risk of fire, electric shock, or personal injury, observe the following:

1. Use this electric fan only in the manner intended by the manufacturer. If you have any questions, contact Factory.
2. Before servicing or cleaning the fan, switch the power off at the service panel and lock out to prevent the power from being switched on accidentally.
3. Follow all local electrical and safety codes, as well as the National Electrical Code (NEC) and Occupational Safety and Health Act (OSHA).
4. Fan motor must be securely and adequately grounded.
5. All working parts should be grounded.
6. When cleaning electrical equipment always use an approved cleaning agent. See CLEANING in NOTES section, page 22.
7. For general ventilation and cooling use only. Do not use if hazardous or explosive materials and vapors are present.

Guidelines For Installation

Before connecting the electric fan, check if the information on the fan motor name plate is in accordance with the actual main supply voltage, phase and frequency.

Warning: To reduce the risk of fire, electric shock, or personal injury, observe the following:

1. Switch off the main power supply and lock out before installing, servicing or making connections to the fan.
2. Installation work and electrical wiring must be done by a qualified person(s) in accordance with all applicable codes and standards, including fire-rated construction.
3. The fan should be securely mounted. Recheck the mounting hardware and tighten as necessary.
4. The fan motor must always be grounded. The installation of a motor protection switch is recommended. See Figure 1 for wiring diagrams.
5. Mount the motor guard if removed. The motor guard must be installed at all times during operation to prevent injury to personnel by rotating fan blade.
6. Use liquid tight electrical fittings and conduit.

SINGLE PHASE TYPE - E

1 PHASE 220V - 50Hz
1 PHASE 220V - 60Hz

1 PHASE 110V - 60Hz
1 PHASE 220V - 60Hz
1 PHASE 240V - 60Hz

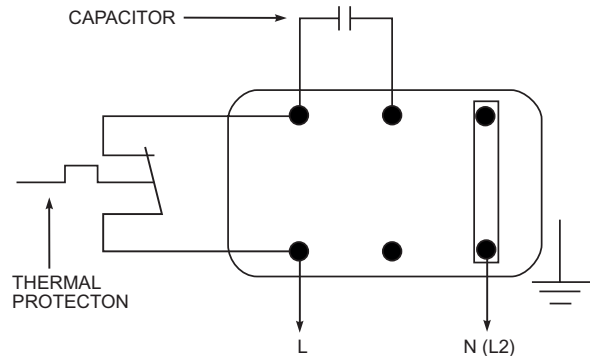

SINGLE PHASE TYPE - D

3 PHASE Δ / \star

3 PHASE 220/380V - 50Hz
3 PHASE 230/400V - 50Hz
3 PHASE 240/415V - 50Hz

3 PHASE 220/380V - 60Hz
3 PHASE 208/360V - 60Hz
3 PHASE 265/460V - 60Hz

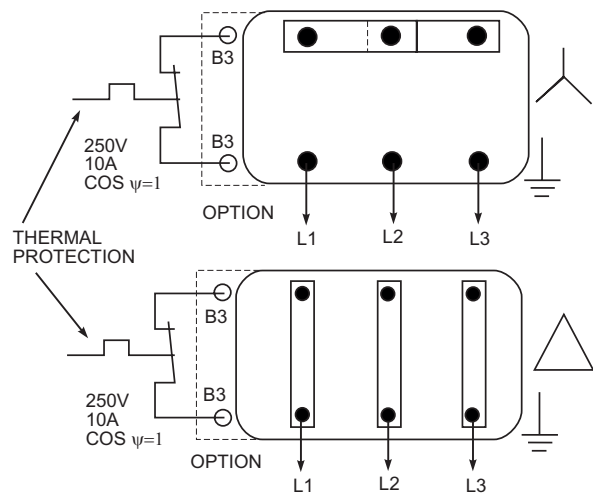
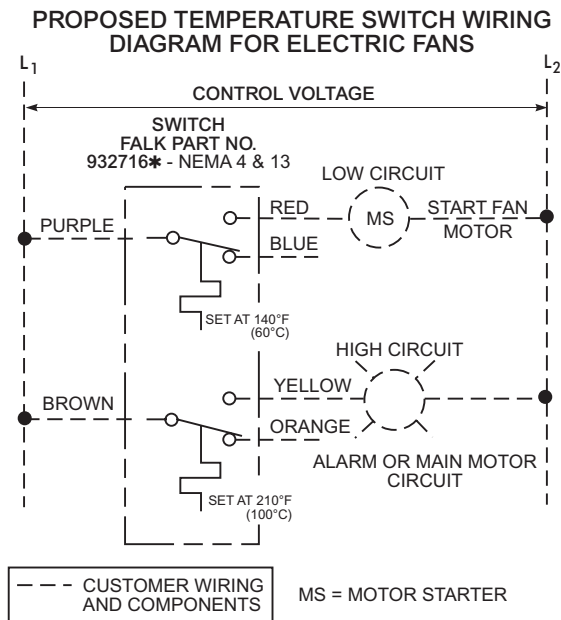

Figure 1

7. A temperature switch is provided to control oil sump temperature. See Figure 2 for proposed wiring. There are two separate circuits in the temperature switch. The low circuit is to operate the electric fan. It is recommended the fan motor be operated by the temperature switch through a motor starter relay (consult applicable local and national electrical codes). The high circuit is provided to operate either a high temperature alarm or main motor shutdown.



* AC RATING - INDUCTIVE LOAD - 50% PF
DC RATING - INDUCTIVE LOAD - L/R = 0.26

AC VOLTS	AMP	DC VOLTS	AMP
125	15	6-12 **	15
250	15	24 **	5
480	15	125	0.05
		250	0.03

* MAXIMUM CONTINUOUS CURRENT

** Reference only.

Figure 2

8. Connect power to the motor using an approved wiring method. See Figure 1 for connection diagrams.
9. Before starting the fan, double check to ensure there are no obstructions that could interfere with proper fan operation and airflow. Verify proper fan rotation, resulting in air flow directed at the adjacent face of the gear drive.

10. Remove proper condensation plug. See Figure 3 below. Do not discard. Plug is to be used during cleaning.

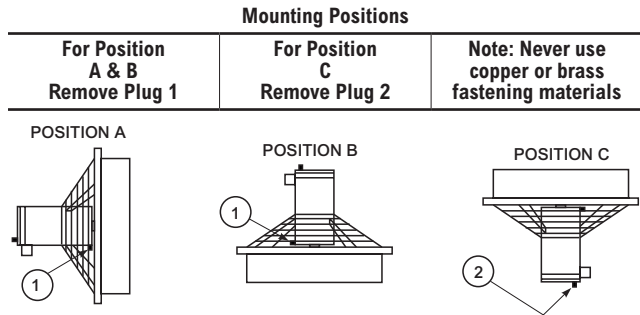

Figure 3

NOTES:

AIR SUPPLY AND TEMPERATURE — Sufficient air supply over the motor must be assured in all circumstances. Limits of operating ambient temperature are 14°F to 113°F (-10°C to 45°C).

RESTRICTION ON USE — Fan blade material is Polypropylene which is unsuitable and/or not recommended for certain chemicals. The following is a partial list of unsuitable chemicals for guideline purposes.

Chloro-Sulphonic Acid	Nitric Acid	Chloroform
Mixture of HNO3-HCL	Esters	1:2 Trichloroethylene
Mixture of HNO3-H2SO4	Benzene	Trichloroethylene
Sulfuric Acid, fuming	Gasoline	Diethyl Ether
Carbon Tetrachloride	Toluene	Chlorine, Liquid
Chlorobenzene	Xylene	

CLEANING — When cleaning fan, both condensation holes (Figure 3, Items 1 and 2) are to be temporarily plugged. If this is not done, guarantee is void. When cleaning electrical equipment, always use an approved cleaning agent.

Internal Cooling Tubes Installation & Maintenance

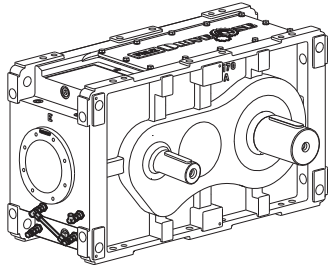

Cooling Tube Description

The internal cooling tube accessory is a network of finned cooling tubes. Factory-installed in the base of a drive housing, for heat removal. The cooling tubes operate submerged in the oil of the drive sump. The revolving elements provide the necessary oil flow around the cooling tubes for efficient heat transfer. No oil pumps are required. The external requirement for the cooling tube system is a clean water hookup supplying a flow rate of 2 gallons (8 liters) per minute at a maximum temperature of 90°F (32°C). An inlet water temperature of 70°F (21°C) is required to obtain the system catalog thermal power rating with a sump oil temperature of 200°F (93°C).

The number of cooling tubes required varies with drive size, type and number of reductions. Cooling tubes are connected in series to maintain the optimum water flow velocity in the tubes with the specified water flow rate of 2 to 5 gallons (8 to 19 liters) per minute. Note: A typical Falk PC cooling assembly requires between 2 to 70 gallons (8 to 265 liters) of water per minute, depending upon PC size and cooling requirements.

All cooling tube system connections are made outside of the housing to eliminate the possibility of water leakage into the drive sump. Seal rings are used at all connections for ease of disassembly and reassembly. The standard cooling tubes are 90/10 copper nickel alloy with aluminum fins. Cooling tube connections are cadmium-plated mild steel with “Buna-N” seal rings.

Water connections are .500”-14 NPT fittings located at the high-speed end. The water outlet is located on the high-speed end of the drive. The water inlet connection is a straight fitting located on the lowest cooling tube in the drive.

The water outlet connection is a right angle fitting (faced up) located on the uppermost tube in the drive. The cooling tube system connections are selected and located so that the cooling system is always full of water during operation for maximum heat transfer. The water inlet and outlet connections may be moved to the opposite end of the drive by removing the water inlet, outlet and all “loop end” fitting assemblies and by reinstalling them on the same tubes at the opposite end of the drive. Refer to the Maintenance Instructions on page 24 and Figures 7 & 8 on page 25 for disassembly and reassembly.

Installation & Operation

1. Connect the .500”-14 NPT straight water inlet fitting to a source of clean, fresh water. Water must be regulated to a minimum of 2 gallons (8 liters) per minute and must not exceed 90°F (32°C).
2. Connect the .500”-14 NPT right angle water outlet fitting (faced up) to an open drain. Do not pressurize the cooling tube system. The turned up water outlet fitting ensures that the system is always full of water during operation.
3. Control water flow rate to between 2 and 5 gallons (8 and 19 liters) per minute to minimize fouling at low flow rates or tube erosion at high flow rates. The water flow rate may be reduced to 1 gallon (4 liters) per minute if clean, fresh (drinking quality) water is used and the sump oil temperature can be maintained within the maximum limit of 200°F (93°C).
4. For shutdowns at ambient temperatures less than 32°F (0°C), drain the cooling tube system by removing the “loop end” assemblies on the end of the drive opposite the water inlet. Refer to Figure 8 on page 25 for typical assemblies and record location of assemblies for reinstallation purposes.

Assembly of Seal Ring Fittings

Note: For disassembly of seal ring fittings, reverse the steps of the following assembly procedure.

1. Figure 1 — Deburr tube end to prevent cutting the rubber seal ring during assembly.
2. Figure 2 — Slide nut and tapered split ring on tube. The large end of the tapered split ring must face the fitting body.
3. Figure 3 — Lubricate the rubber seal ring. Insert the tube into the fitting body past the rubber seal ring.
4. Figure 4 — Slide the tapered split ring against the fitting body. Lubricate O.D. of tapered split ring with #2 bearing grease.
5. Figure 5 — Assemble nut to fitting and tighten hand tight. Turn nut with a wrench one turn or until the tapered split ring is flush with the end of the nut.

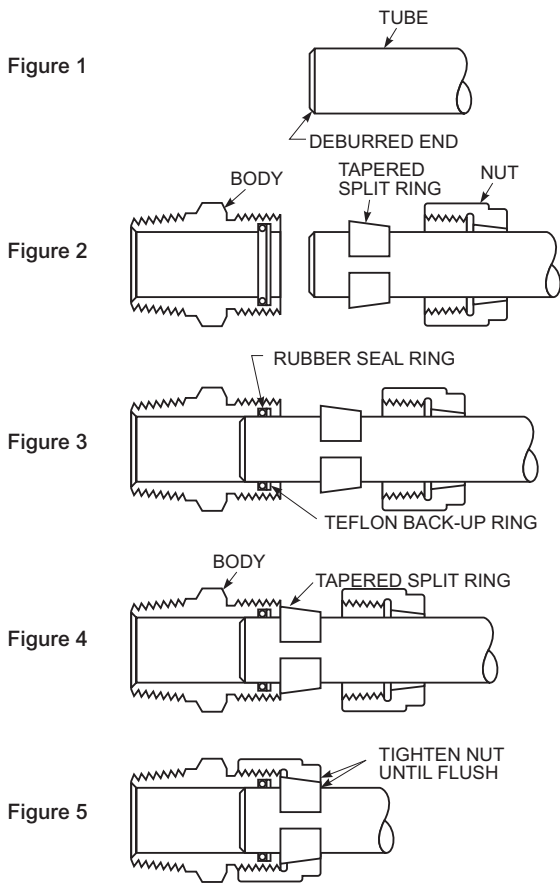

Maintenance Instructions

The cooling tube system is designed to be removed from the drive housing without disturbing the drive or its foundation, provided sufficient room is available at either end of the housing for tube withdrawal. All tube connections are outside the drive and are of the seal ring type for ease of maintenance and reusability.

Light coatings of sludge or scale will cause a reduction in heat transfer capacity of the system. Therefore, periodic cleaning of the system may be required to restore the heat transfer capacity.

The cooling tube system may be cleaned by flushing with commercially available cleaning compounds such as Oakite or Dowell. The commercially available cleaning compounds are corrosive and must be used in accordance with their manufacturer's recommendations. Cleaning may also be accomplished by means of a rod or wire brush. Remove the tube end seal ring fittings (Figures 7 & 8 on page 25) and pass a .500" (12 mm) diameter rod or wire brush through the tubes to remove the scale. Tube I.D. is .527" (13.39 mm). After cleaning all tubes, reinstall the tube end seal ring fittings.

The outside of the cooling tubes (aluminum fins) may be cleaned by removing the tubes from the housing and cleaning with steam or a suitable solvent. To remove the tubes from the housing, remove all seal ring fittings from the tubes. Remove the 1.250-11 NPT x .750-14 NPT pipe bushings from one end of the drive. A special deep well, thin wall socket (1.812 hex by 7" deep) may be required to remove and reinstall the pipe bushings.

CAUTION: Take care not to damage cooling tube ends during disassembly, cleaning and reassembly.

Withdraw the tubes from the housing through the 1.250-11 NPT holes using a .375" (10 mm) diameter rod through the tube as a disassembly and reassembly aid. After cleaning, reinstall the tubes in the drive. Coat pipe bushing threads with thread sealant and reinstall the pipe bushings and tube fittings in the reverse order of disassembly. Install the loop end assemblies in the same positions as before disassembly.

See left for seal ring fitting assembly procedures. Seal ring fittings use standard No. 114 (.625 I.D. x .812 O.D. x .094 W) Buna-N seal rings if replacements are required.

Accessories

A sump temperature sensing water flow controller and sump temperature indicator (thermometer) are available accessories for the internal cooling tube system. It is recommended that a thermometer be used with a water flow controller. Additional holes in the housing are required for these accessories and should be referred to the Factory at the time of order.

Water Flow Control Valve

A water flow control valve is recommended where the availability or cost of water is at a premium or where automatic water shutoff or constant temperature is desired. The standard water flow control valve is an adjustable, capillary-type, temperature sensing, flow modulating valve. The flow control valve should be installed in series with a ball valve to limit maximum water flow. Refer to Figure 6 for recommended plumbing diagram. The water flow control valve will control water flow rates to less than 2 gallons (8 liters) per minute, however, the cooling tubes will be subject to increased fouling and may require cleaning at more frequent intervals.

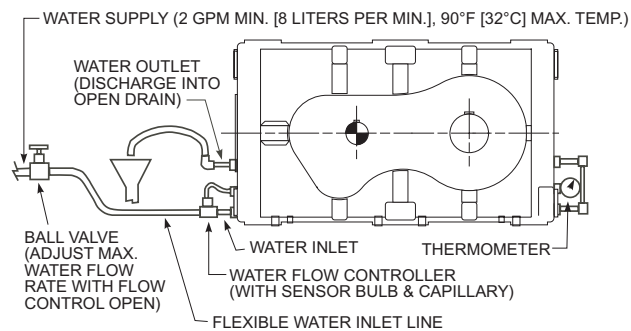

Figure 6

Thermometer

The standard thermometer is a bimetallic, dial-type instrument.

Cooling Tube Inlet & Outlet Connection Assemblies

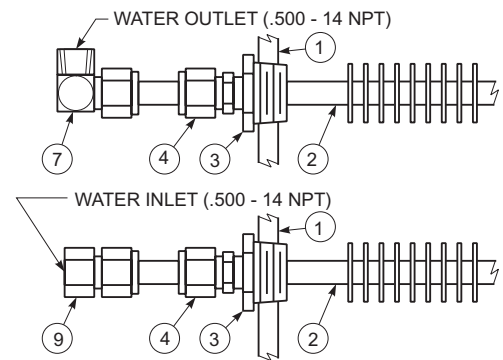

Figure 7

Cooling Tube Loop End Connection Assemblies

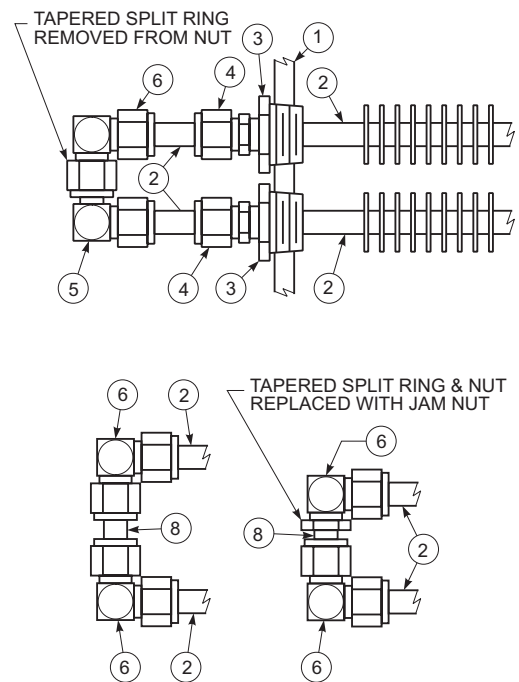

Figure 8

- ① Drive Housing Wall
- ② Cooling Tube
- ③ Pipe Bushing (1.250 x 7.50)
- ④ Male Connector (Lenz 100-10-12)
- ⑤ Special "Lenz" Elbow Fitting (Falk Part #1199037)
- ⑥ Union Elbow (Lenz 500-10)
- ⑦ Female Elbow (Lenz 450-10)
- ⑧ Tubing (.625 O.D.)
- ⑨ Female Connector (Lenz 250-10)

Thrust Plate & Fastener Usage

Thrust plate usage is optional. To use, remove hollow shaft cover from gear drive. Slide bushing with shaft key onto driven shaft near final position (shaft length “N” - 5 mm or 0.20 in.) and slide gear drive onto driven shaft. Tighten bushing nut to specified torque. Verify location of drive on driven shaft to be within angular limits of the drive torque arm. Install thrust plate and thrust plate retaining ring. Coat four or five engaging threads of the retention fastener with a low-strength thread locking compound and install snug tight. Install hollow shaft cover.

Table 1 — Metric & Inch Bore Bushings

Drive Size	Retention Fastener *		Backing Bolt †		Removal Bolt †		Shaft Length (N) ‡		Keyway (L) ‡	
	mm	Inch	mm	Inch	mm	Inch	mm	Inch	mm	Inch
M1130	M20 x 2.5 x 75	.750-10UNC x 3.00	M20 x 2.5 x 40	.750-10 x 1.50	M24 x 3 x 70	M24 x 3 x 70	341	13.43	284	11.18
M1140	M24 x 3 x 90	1.000-8UNC x 3.50	M24 x 3 x 45	1.00-8 x 2.00	M30 x 3.5 x 80	M30 x 3.5 x 80	386	15.20	319	12.55
M1150	M24 x 3 x 90	1.000-8UNC x 3.50	M24 x 3 x 45	1.00-8 x 2.00	M30 x 3.5 x 80	M30 x 3.5 x 80	406	15.98	334	13.15
M1160	M24 x 3 x 90	1.000-8UNC x 3.50	M24 x 3 x 45	1.00-8 x 2.00	M30 x 3.5 x 80	M30 x 3.5 x 80	454	17.87	407	16.02
M1170	M30 x 3.5 x 100	1.125-7UNC x 3.75	M30 x 3.5 x 60	1.125-7 x 2.25	M36 x 4 x 90	M36 x 4 x 90	436	17.17	392	15.44
M1180	M30 x 3.5 x 100	1.125-7UNC x 3.75	M30 x 3.5 x 60	1.125-7 x 2.25	M36 x 4 x 90	M36 x 4 x 90	503	19.80	450	17.72
M1190	M30 x 3.5 x 100	1.125-7UNC x 3.75	M30 x 3.5 x 60	1.125-7 x 2.25	M36 x 4 x 90	M36 x 4 x 90	549	21.61	502	19.76

★ Retention fastener is factory-supplied (Grade 8.8 metric & Grade 5 inch).

† Backing and removal bolts are user-supplied (Removal bolt Grade 8.8 minimum).

‡ Shaft length (N) and Keyway (L) are required when using thrust plate and supplied retention fastener.

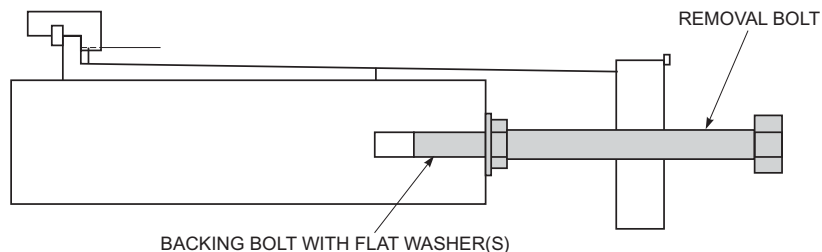
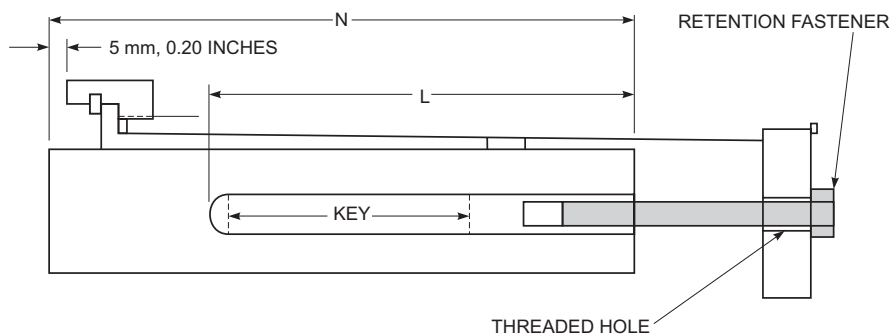

AUXILIARY RELEASE SYSTEM - USER-PROVIDED WHEN REQUIRED
 LOOSEN BUSHING NUT AND REMOVE NUT RETAINING RING BEFORE USING
 ADD FLAT WASHERS AT BACKING BOLT IF NEEDED

Directions for Inverting Drives DH2 & DB3

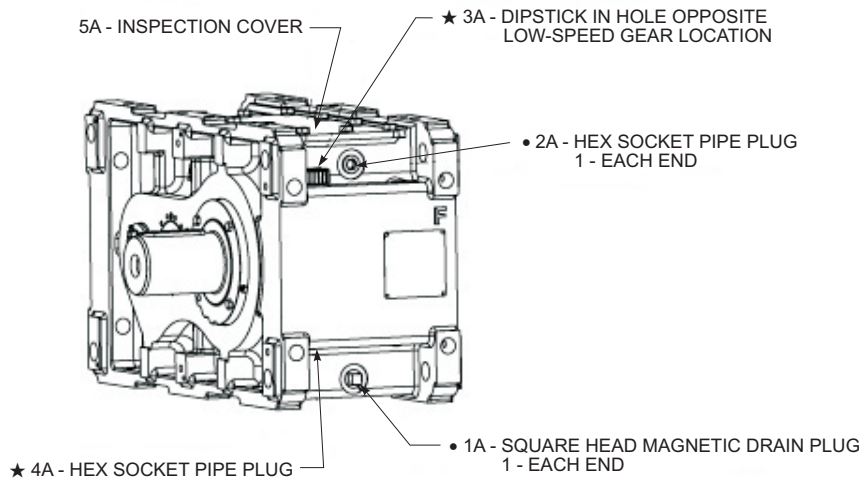

STANDARD MOUNT
(INSPECTION COVER UP)

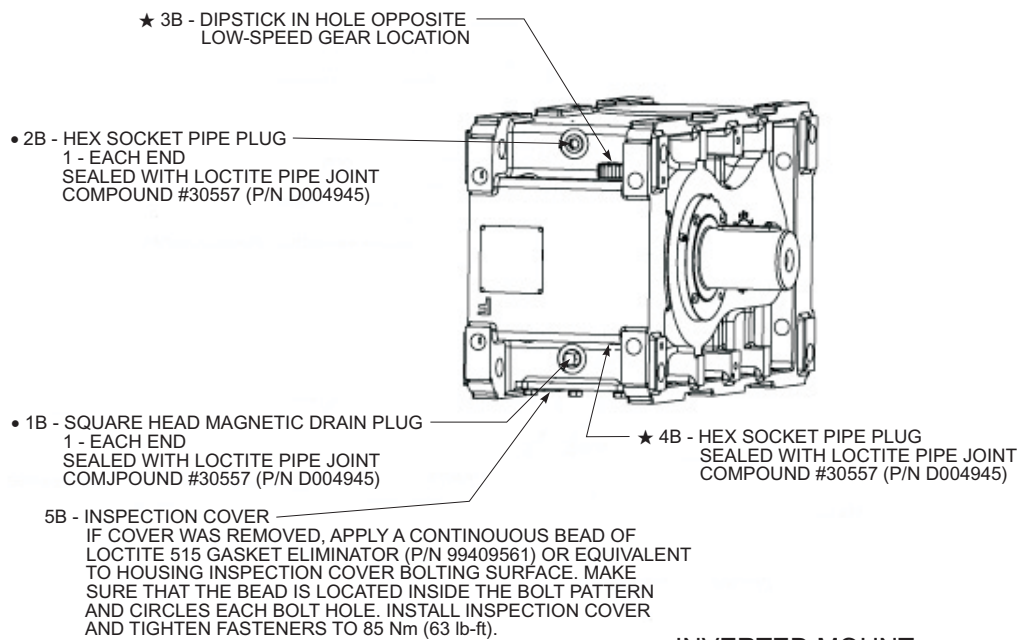

INVERTED MOUNT
(INSPECTION COVER DOWN)

- RELOCATE MAGNETIC DRAIN PLUGS (BOTH ENDS) FROM 1A TO 1B AND SWITCH THE SOCKET HEAD PLUGS FROM 2A TO 2B.
- ★ RELOCATE THE DIPSTICK FROM 3A TO 3B AND SWITCH THE SOCKET HEAD PLUGS FROM 4A TO 4B. BE SURE TO LOCATE THE DIPSTICK ON THE OPPOSITE SIDE FROM THE LOW-SPEED GEAR TO AVOID INTERFERENCE.