

HOW TO USE THIS MANUAL

This manual provides detailed instructions on installation and maintenance of gear drives Types GHB, Y, YB, YBX & YF. Use the table of contents below to locate required information.

CAREFULLY FOLLOW THE INSTRUCTIONS IN THIS MANUAL FOR OPTIMUM PERFORMANCE AND TROUBLE FREE SERVICE.

TABLE OF CONTENTS

Installation Instructions.....	Pages 1 & 2
Shaft Connections	Pages 2 & 3
Tightening Torques.....	Page 3
Lubrication Recommendations.....	Pages 4 thru 9
Lubricant Selection Process	Page 4
Preventive Maintenance.....	Page 5
Lubricant Analysis and Changes.....	Page 8
Stored and Inactive Gear Drives.....	Page 9
Food Grade Lubricants	Page 10 thru 13
Food Grade Lubricant Selection Process.....	Page 10
Preventive Maintenance.....	Page 12
Lubricant Analysis and Changes.....	Page 12
Stored and Inactive Gear Drives.....	Page 13

INTRODUCTION

Credit for long service and dependable operation of a gear drive is often given to the engineers who designed it, or the craftsmen who constructed it, or the sales engineer who recommended the type and size. Ultimate credit belongs to the mechanic on the job who worked to make the foundation rigid and level, who accurately aligned the shafts and carefully installed the accessories, and who made sure that the drive received regular lubrication. The details of this important job are the subject of this manual.

NAMEPLATE — Operate Falk gear drives only at horsepower, speed and ratio shown on nameplate. Before changing any one of these, submit complete nameplate data and new application conditions to the Factory for correct oil level, parts and application approval.

DISASSEMBLY AND ASSEMBLY — Disassembly & assembly instructions and parts guides are available from the Factory or Rexnord Account Executives. When requesting information, please give complete data from the nameplate on the gear drive; Model, M.O.Number, Date, RPM, and Ratio.

WARNING: Consult applicable local and national safety codes for proper guarding of rotating members. Lock out power source and remove all external loads from drive before servicing drive or accessories.

WARRANTY

Rexnord Industries (the “Company”) warrants that, for a period of three years from the date of shipment, the product described herein will deliver successfully its rated output as indicated on the nameplate, provided, it is properly installed and maintained, correctly lubricated, and operated in the environment and within the limits of speed, torque or other load conditions for which it was sold. Such product is expressly not warranted against failure or unsatisfactory operation resulting from dynamic vibrations

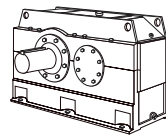

Type Y

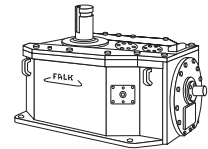

Type YBX

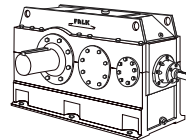

Type YB

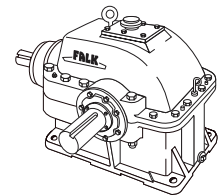

Type GHB

imposed upon it by the drive system in which it is installed unless the nature of such vibrations has been fully defined and expressly accepted in writing by the Company as a condition of operation.

INSTALLATION INSTRUCTIONS

The following instructions apply to standard Falk Type GHB, Y, YB, YBX, & YF drives. If a drive is furnished with special features, refer to the supplementary instructions shipped with the drive.

WELDING — Do not weld on the gear drive or accessories without prior approval from Rexnord Industries, LLC. Welding on the drive may cause distortion of the housing or damage to the bearings and gear teeth. Welding without prior approval could void the warranty.

EFFECTS OF SOLAR ENERGY — If the gear drive operates in the sun at ambient temperatures over 100°F (38°C), then special measures should be taken to protect the drive from solar energy. This protection can consist of a canopy over the drive or reflective paint on the drive. If neither is possible, a heat exchanger or other cooling device may be required to prevent the sump temperature from exceeding the allowable maximum.

HORIZONTAL MOUNTING — Mount gear drive with base horizontal, unless it has been specifically ordered for mounting in another position. If it is necessary to mount the drive in a different position from that for which it was ordered, consult Rexnord for changes necessary to provide proper lubrication.

NON-HORIZONTAL MOUNTING — For gear drives with non-horizontal mounting, including tilted, vertical and wall mounted, refer to instructions provided with the drive for oil levels and bearing lubrication.

FOUNDATION, GENERAL — To facilitate oil drainage, elevate the gear drive foundation above the surrounding floor level. If desired, replace the drive oil drain plug with a valve, but provide a guard to protect the valve from accidental opening or breakage.

When an outboard bearing is used, mount drive and outboard bearing on a continuous foundation or bedplate and dowel both in place.

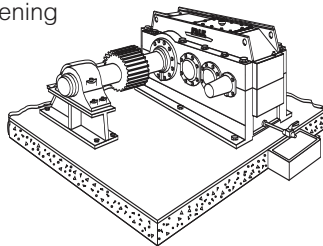

FOUNDATION, STEEL —

When mounting gear drive on structural steel, it is recommended that an engineered design be utilized for a pedestal, adapter base or bed to provide sufficient rigidity, to prevent induced loads from distorting the housing and causing gear misalignment. In the absence of an engineered design, it is recommended that a base plate, with thickness equal to or greater than the thickness of the drive feet, be securely bolted to steel supports and extend under the entire drive as illustrated.

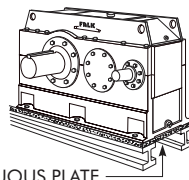

CONTINUOUS PLATE

FOUNDATION, CONCRETE —

If a concrete foundation is used, allow the concrete to set firmly before bolting down the gear drive.

For the best type of mounting, grout structural steel mounting pads into the mounting base, as illustrated, rather than grouting the drive directly into the concrete.

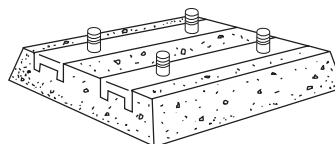

Motors and other components mounted on motor plates or motor brackets may become misaligned during shipment. ALWAYS check alignment after installation. Refer to Page 3 for coupling alignment instructions.

MOTOR BRACKETS — The weight, location and starting torque of the motor will cause some brackets to deflect downward and to twist. This movement is within allowable engineered limits for motor-drive selections from the Falk selection guide. If the customer considers the movement excessive, jackscrew supports for the bracket extension are available from Rexnord. To compensate for deflection caused by heavy motors AND to get CORRECT COUPLING ALIGNMENT, use more shims under the rear motor feet than the front feet.

GEAR DRIVE ALIGNMENT — Align drive with driven equipment by placing broad, flat shims under all mounting pads. Start at the low speed shaft end and level across the length and then the width of the drive. Check with a feeler gauge to make certain that all pads are supported to prevent distortion of housing when drive is bolted down. After drive is aligned with driven equipment and bolted down, align prime mover to drive input shaft. Refer to Page 3 for coupling alignment.

If equipment is received from Rexnord mounted on a bedplate, the components were accurately aligned at Rexnord with the bedplate mounted on a large, flat assembly plate. Shim under the bedplate foot pads until the gear drive is level and all feet are in the same plane.

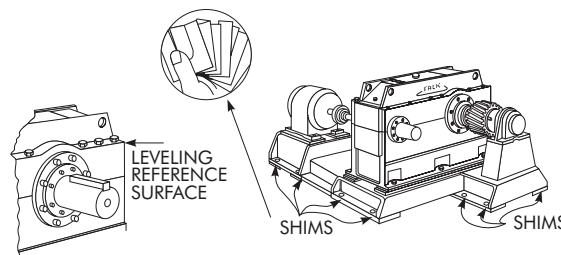

Check high speed shaft coupling alignment. If the coupling is misaligned, the bedplate is shimmed incorrectly. Re-shim bedplate and recheck high speed coupling alignment. If necessary, realign motor.

SHAFT CONNECTIONS

WARNING: Provide suitable guards in accordance with OSHA standards.

COUPLING CONNECTIONS — The performance and life of any coupling depends largely upon how well the coupling is installed and serviced. Refer to the coupling manufacturer's manual for specific instructions.

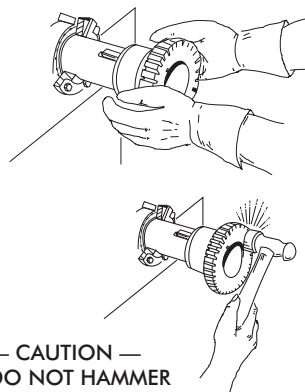

CORRECT METHOD
Heat interference fitted coupling hubs, pinions, sprockets or pulleys to a maximum of 275°F (135°C) and slide onto gear drive shaft.

INCORRECT METHOD
DO NOT drive coupling hub, pinion, sprocket or pulley onto the shaft. An endwise blow on the shaft/coupling may damage gears and bearings.

— CAUTION —
DO NOT HAMMER

FALK COUPLINGS — (Except fluid type) Detailed installation manuals are available from the Factory, your local Rexnord Account Executive or Distributor—just provide size and type designations stamped on the coupling. For lubricant requirements and a list of typical lubricants meeting Rexnord specifications, refer to appropriate coupling service manual.

Flanged Type Rigid Couplings are typically used on drives with vertical output shafts. The low speed shaft extension ends of the solid vertical shaft drives are drilled and tapped to accommodate coupling keeper plates. Tightening torques for fasteners, including keeper plate fasteners are listed in Table 1, Page 3.

FALK FLUID COUPLINGS — Refer to the installation manual furnished with the fluid coupling for installation, alignment and startup instructions.

GAP AND ANGULAR ALIGNMENT — If possible, after mounting coupling hubs, position the driving and driven equipment so that the distance between shaft ends is equal to the coupling gap. Align the shafts by placing a spacer block, equal in thickness to required gap, between hub faces, as shown above, and also at 90° intervals around the hub. Check with feelers.

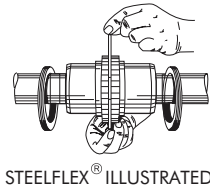

OFFSET ALIGNMENT — Align driving and driven shafts so that a straight edge will rest squarely on both couplings hubs as shown to the right and also at 90° intervals. Tighten foundation bolts of the connected equipment and recheck alignment and gap.

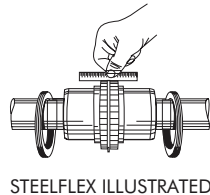

SPROCKETS, PULLEYS OR SHEAVES — Mount power take-offs as close to the gear drive housing as possible to avoid undue bearing load and shaft deflection.

Align the output shaft of the gear drive square and parallel with the driven shaft by placing a straightedge across the face of the sprockets or sheaves as illustrated. Check horizontal shaft alignment by placing one leg of a square against the face of the sheave or sprocket with the spirit level on the horizontal leg of the square.

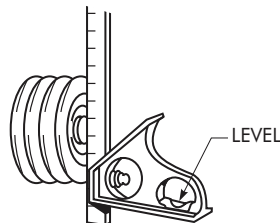
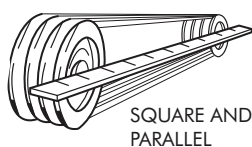
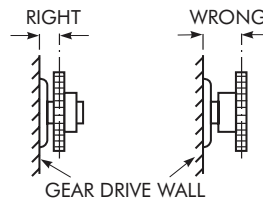

DO NOT over tighten belts or chains. Adjust chains to manufacturers' specifications. Adjust belts as follows:

The ideal tension is the lowest tension at which the belt will not slip under peak load conditions. Check the belt tension frequently during the first 24 to 48 hours of run-in operation. Over tightening belts shortens belt and bearing life. Keep belts free from foreign material which may cause slippage. Inspect the V-belt periodically; tighten the belts if they are slipping.

OUTBOARD BEARING — Mount the outboard bearing and gear drive on a common foundation so that they will shift as an assembly if settling should occur. Bring the outboard bearing to the correct horizontal position with broad flat shims under the mounting pad. Align accurately so that the load is equally divided between the two drive bearings and the outboard bearing. Mount a stop bar against the pillow block foot on the load side when large horizontal load components are exerted on the pillow block.

PINION MOUNTING — Mount pinion as close to the unit as possible to avoid undue bearing load and shaft deflection. Refer to the Factory for pinion alignment instructions.

BACKSTOPS — To prevent damage to backstops due to incorrect motor shaft rotation at start up, couplings are NOT assembled when gear drives are furnished with backstops. After completing the electrical connection, check motor and gear drive shaft rotations. Then complete alignment and assembly of coupling.

FASTENER TIGHTENING TORQUES

Use the tightening torque values specified in Table 1, for fastening Falk gear drives, motors, keeper plates and accessories to their mounting surfaces with non-lubricated fasteners. DO NOT use these values for "torque locking" fasteners or for fastening components with aluminum feet or with soft gaskets or vibration dampers on the mounting surface. If the tightening torque exceeds the capacity of the torque wrench, use a torque multiplier. Use Grade 5 fasteners for diameters through 1.50", for larger diameter fasteners, use ASTM A-354 Grade BC.

TABLE 1 — Tightening Torques — lb-in
DO NOT LUBRICATE FASTENERS

Thread Dia-UNC	Metal to Metal	Metal to Concrete	Thread Dia-UNC	Metal to Metal	Metal to Concrete
.250-20	90	70	1.250-7	12600	10000
.3125-18	185	145	1.375-6	16500	13000
.375-16	330	255	1.500-6	22100	17500
.500-13	825	640	1.750-5	23700	18700
.625-11	1640	1280	2.000-4.5	37000	29000
.750-10	2940	2290	2.250-4.5	52000	41000
.875-9	4560	3750	2.500-4	72000	56000
1.000-8	6800	5600	2.750-4	98000	77000
1.125-7	8900	7000	3.000-4	125000	99000

WATER COOLING

WATER COOLED HEAT EXCHANGERS — Install a shut-off or control valve in the water line to the heat exchanger to regulate the water flow through the exchanger. Also install a water flow gauge between the control valve and the exchanger to determine actual flow rate. Discharge water to an OPEN DRAIN to prevent back pressure.

LUBRICATION RECOMMENDATIONS

INTRODUCTION

Carefully follow instructions on the drive nameplate, warning tags and installation manuals furnished with the drive.

Lubricants listed in this manual are typical products ONLY and should not be construed as exclusive recommendations. Industrial type petroleum-based rust and oxidation inhibited (R & O), industrial type extreme pressure (EP) or industrial type micropitting resistant gear lubricants are the recommended gear lubricants. They can be formulated using petroleum or synthetic base stocks.

The section on food grade lubricants provides guidance selecting lubricants for applications needing this class of lubricants. Food grade lubricants are formulated using petroleum or different types of synthetic base stocks.

LUBRICANT SELECTION PROCESS

1. Refer to Table 3 or 4 for proper lubricant viscosity grade based on ambient temperature range. See Falk GMax 6000 paragraph on this page for ambient air temperature range if using this lubricant.
2. Refer to Table 2 for summary of lubricant type.
3. Using proper lubricant table and viscosity grade, select desired lubricant manufacturer name.
4. Refer to drive nameplate for approximate oil capacity to purchase.

TABLE 2 — Summary of Lubricant Type and Greases

Petroleum-Based		
R & O Inhibited See Table 5A	Extreme Pressure (EP) See Table 5B	Micropitting Resistant See Table 5C
Synthetic Lubricant, Polyalphaolefin Type (PAO)		
R & O Inhibited See Table 6A	Extreme Pressure (EP) See Table 6B	Micropitting Resistant See Table 6C
Synthetic Lubricant, Polyalphaolefin Glycol Type (PAG)		
See Falk GMax 6000 (Paragraph to Right)		
Conventional Grease		
See Table 7		
Food Grade Lubricant & Grease		
See Page 10		

VISCOSITY (IMPORTANT)

The proper viscosity grade for petroleum-based lubricant is found in Table 3. For synthetic lubricant viscosity grades, refer to Table 4 and the “Synthetic Lubricants” paragraphs.

Viscosity grade is determined by ambient air temperature in immediate vicinity of gear drive. Lubricant selections must have a pour point at least 10°F (5.5°C) below the expected minimum ambient starting temperature.

If a gear drive operates in a typical indoor environment where the ambient temperature is within 70° to 125°F (21° to 52°C), the oil viscosity may be increased one ISO grade above that shown for the 50° to 125°F (10° to 52°C) range. That is, ISO VG 320 (AGMA 6) or ISO VG 460 (AGMA 7) may be substituted for an ISO VG 220 (AGMA 5) or ISO VG 320 (AGMA 6) respectively, under this ambient condition.

LUBRICANT TYPES

PETROLEUM-BASED LUBRICANTS (TABLES 5A, 5B & 5C) — Industrial type petroleum-based rust and oxidation inhibited (R & O) gear lubricants are the most common and readily available general purpose gear lubricants.

SYNTHETIC LUBRICANTS (TABLES 6A, 6B & 6C) — Synthetic lubricants of the polyalphaolefin (PAO) type are recommended for cold climate operation, high temperature applications, extended temperature range (all season) operation and/or extended lubricant change intervals. The proper viscosity grade of synthetic lubricant is given in Table 4.

Polyalkylene glycols (PAG) are another class of synthetic lubricants. They have similar performance properties as PAO synthetics — low pour point, stable at elevated temperature and high viscosity index. PAG's have exceptional tolerance to water contamination.

WARNING: Polyalkylene glycols (PAG's) are not compatible with petroleum mineral oil or PAO synthetic lubricants and must not be topped off with either lubricant. In addition, petroleum mineral oils or PAO synthetic lubricants must not be used to top off systems containing PAG's. Do not use PAG's in gear drives with painted interior housing walls unless paint compatibility is checked. Compatibility with oil seals and gasket materials must be checked prior to use. PAG lubricants are not compatible with polycarbonate sight glass. Use glass sight glass.

Falk GMax 6000 — Rexnord markets Falk GMax 6000, a polyalkylene glycol lubricant. It is available in ISO VG 135 and covers ambient air temperature range -30° to +125°F (-34° to +52°C). Gear drives equipped with internal backstop can use GMax in ambient temperatures above -20°F (-29°C).

WARNING: GMax 6000 is not compatible with petroleum mineral oil or PAO synthetic lubricants and must not be topped off with either lubricant. In addition, petroleum mineral oils or PAO synthetic lubricants must not be used to top off systems containing GMax 6000. Do not use GMax 6000 in gear drives with painted interior housing walls unless paint compatibility is checked. Compatibility with oil seals, and gasket materials must be checked prior to use. GMax 6000 is not compatible with polycarbonate sight glass. Use glass sight glass.

ANTI-WEAR (AW) LUBRICANTS — For moderately loaded gear drives or operating conditions challenging for conventional R & O oils, industrial type anti-wear (AW) lubricants are suggested. These lubricants contain anti-wear additives that provide stronger thicker lubricant film to help maintain surface separation. Synthetic lubricants by inherent nature of base stock properties provide anti-wear performance.

EXTREME PRESSURE (EP) LUBRICANTS (TABLES 5B & 6B) — For highly loaded drives or for drives loaded in excess of original estimates, industrial-type petroleum EP lubricants are preferred. EP lubricants are manufactured from petroleum or synthetic base lubricants. Anti-scuff is another term used to describe EP lubricants.

MICROPITTING RESISTANT LUBRICANTS (TABLES 5C & 6C) — Micropitting resistant lubricants are specially developed for surface hardened gearing commonly used in modern industrial gear drives. These lubricants contain additives to resist formation of micropitting and other conventional forms of gear wear. Highly loaded gear drives or applications where operating loads are not well defined may benefit from this type of lubricant. Generally lubricants are available in limited number of viscosity grades.

WARNING: LUBRICANTS IN FOOD PROCESSING INDUSTRY — Generally conventional gear lubricants are classified as H2 by NSF (National Sanitation Foundation) since they contain harmful substances and should not be used in the food processing industry. Lubricants registered as H1 by NSF are suitable for food processing applications.

CLIMATE CONDITIONS — Ambient temperature in immediate vicinity of gear drive is very important for determining viscosity grade. Table 3 provides viscosity grade selections for petroleum-based lubricants. See Table 4 for synthetic lubricants.

TABLE 3 — Viscosity Grade Recommendations For Petroleum-Based Lubricants

Drive Description	Classification Symbol (Drive Type)	Drive Size	Normal Climates				
			+15° to +60°F (-9° to +16°C)		+50° to +125°F (+10° to +52°C)		
			ISO-VG	AGMA	ISO-VG	AGMA	
Parallel Shaft and Horizontal Right Angle	Y1	50-135, 2050-2135	100	3	220	5	
	YF1	1080-1135	100	3	220	5	
	Y1	140-195, 2140-2165	150	4	220	5	
	YF1	1140-1195	150	4	220	5	
Roller Bearings Fabricated Steel Housings	Y2 & YB2	50-195	150	4	220	5	
	Y2 & YB2	2050-2245	150	4	220	5	
Vertical Right Angle Fabricated Steel Housings	Y3, YB3 & 4	50-135, 2050-2135	150	4	220	5	
	Y3, YB3 & 4	140-195, 2140-2245	220	5	320	6	
Right Angle	2000 GHB1	2050-2120	100	3	220	5	
	GHB	3-5	100	3	220	5	
	Horizontal and Vertical Cast Iron Housings	GDB	6-9	See Manual 128-010			
		GRB	10-12				
GDX		4,5					
	GDX, GRX	6-12					
Parallel Shaft Sleeve and Roller Bearings Cast Iron Housings	GHC, GHF	5	See Manual 128-010				
	GDA, GDF	6-9					
	GRA, GRF	10-13					
Parallel Shaft Semi-high Speed Sleeve, Roller and Ball Bearings	YHF1	1080-1135	See Manual 128-010				
	YH1	2050-2125					
	YH2	2050-2175					
	GHCH	5					
	GHCH	6-13					
Parallel Shaft High Speed Sleeve Bearings	YQA, YPA	All Sizes	See Manual 128-010				

OIL PUMPS — When selecting a lubricant for a gear drive equipped with an oil pump, cold temperature oil viscosity is important. Lubricant viscosity at start-up generally should not exceed 1725 cSt (8,000 SSU). When exceeding this viscosity, pump cavitation is possible, preventing oil circulation. A sump heater may be required or it may be possible to use a lower viscosity oil to minimize pump cavitation.

OIL LEVELS

Prior to filling gear drives, remove the inspection cover and flood the oil troughs with a generous flow of oil to the bearings. Fill the drive with oil to the level indicated on the oil dipstick. Approximate oil capacities are given on the drive nameplate.

LUBRICATION SYSTEMS

SPLASH LUBRICATED UNITS — Standard Type GHB, Y, YB, YBX, & YF drives are splash lubricated. The lubricant is picked up by the revolving elements and distributed to all bearings and gear meshes.

OIL PUMPS — Occasionally gear drives are equipped with oil pumps, either for special lubrication considerations or for external cooling. When so equipped, run the lubrication system for several minutes to fill the system components. Verify that the pump is circulating oil properly then recheck the oil level.

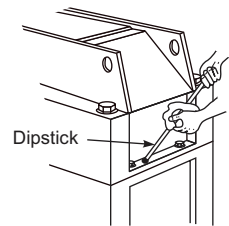

Before starting the gear drive, rotate the input shaft by hand to check for any obstruction. Then start the drive and allow it to run without a load for several minutes. Shut down and recheck oil level. Add oil to compensate for cooler, filter, etc., oil capacities. If everything is satisfactory, the drive is ready for operation.

PREVENTIVE MAINTENANCE

AFTER FIRST WEEK — Check alignment of the total system and realign where necessary. Also, tighten all external bolts and plugs where necessary. DO NOT readjust the internal gear or bearing settings in the drive, these were permanently set at the factory.

OIL FILTER SERVICE — Record oil pressure at oil filter indicating gauge with drive at operating temperature, with fresh oil. Replace oil filter when oil pressure INCREASE reaches 10 psi with drive at operating temperature. Replacement filter elements (Falk Part No. 10092262, Gresen K-22002 or equivalent 30 micron) are available from the factory.

AFTER FIRST MONTH'S SERVICE — Proceed as follows:

1. Operate drive until old sump oil reaches normal operating temperature. Shut the drive down and drain immediately.
2. Immediately flush drive with an oil of the same type and viscosity grade as the original charge (warmed to approximately 100°F (38°C) in cold weather). Rapidly pour or pump a charge equal to 25-100% of the initial fill volume through the drive or until clean oil flows through the drain.
3. Close the drain and refill the drive to the correct level with new oil of the correct type and viscosity.

TABLE 4 — Viscosity Grade Recommendations for Synthetic Lubricants

Ambient Temperature Range	Cold Climates		Normal Climates		
	-30° to +10°F (-34° to -12°C)	-15° to +50°F (-26° to +10°C)	0° to +80°F (-18° to +27°C)	+10° to +125°F (-12° to +52°C)	+20° to +125°F (-7° to +52°C)
ISO Viscosity Grade	32	68	150	220	320
AGMA Viscosity Grade	0	2	4	5	6

TABLE 5A — Petroleum Based R & O (Rust & Oxidation) Inhibited Lubricants [▲]
Maximum Operating Temperature of Lubricants 200°F (93°C)

ISO Viscosity Grade	100	150	220	320
AGMA Viscosity Grade	3	4	5	6
Viscosity cSt @ 40°C ■	90-110	135-165	198-242	288-352
Viscosity SSU @ 100°F	417-510	626-765	918-1122	1335-1632
Manufacturer	Lubricant Name	Lubricant Name	Lubricant Name	Lubricant Name
Castrol Industrial Lubricants	Hyspin AWS 100 Castrol Paradene R&O 100 Castrol Paradene AW 100	Hyspin AWS 150 Castrol Paradene R&O 150 Castrol Paradene AW 150	Hyspin AWS 220 Castrol Paradene R&O 220 Castrol Paradene AW 220	--- Castrol Paradene R&O 320 Castrol Paradene AW 320
Chevron / Texaco / Caltex	Rando HD 100	Rando HD 150	Rando HD 220	Rando HD 320
Citgo Petroleum Corp.	Pacemaker T 115	Pacemaker T 150	Pacemaker SD 220	Pacemaker SD 320
Exxon Mobil / Esso	DTE Heavy Vacuoline 525	DTE Oil Extra Heavy Vacuoline 528	DTE Oil BB Vacuoline 533	DTE Oil AA Vacuoline 537
Petro-Canada Lubricants	TurboFlo R&O 100	TurboFlo R&O 150	TurboFlo R&O 220	TurboFlo R&O 320
Phillips 66 / Conoco / 76 Lubricants / Kendall	Multipurpose R&O 100	Multipurpose R&O 150	Multipurpose R&O 220	Multipurpose R&O 320
Shell Oil Co.	Morlina S2 B 100 Morlina S2 BA 100	Morlina S2 B 150 Morlina S2 BA 150	Morlina S2 B 220 Morlina S2 BA 220	Morlina S2 B 320 Morlina S2 BA 320
Total Lubricants USA / Keystone Div. Penwalt Corp.	Azolla ZS 100	Cirkan ZS 150	Cirkan ZS 220	Cirkan ZS 320
Whitmore Manufacturing Company	Hyperion 100	Hyperion 150	Hyperion 220	Hyperion 320

[▲] Minimum viscosity index of 90.
 ■ Kinematic viscosity in units of mm²/s is equivalent to cSt (centistokes).

TABLE 5B — Petroleum Based EP (Extreme Pressure) Lubricants [▲]
Maximum Operating Temperature of Lubricants 200°F (93°C)

ISO Viscosity Grade	100	150	220	320
AGMA Viscosity Grade	3	4	5	6
Viscosity cSt @ 40°C ■	90-110	135-165	198-242	288-352
Viscosity SSU @ 100°F	417-510	626-765	918-1122	1335-1632
Manufacturer	Lubricant Name	Lubricant Name	Lubricant Name	Lubricant Name
Castrol Industrial Lubricants	Alpha SP 100	Alpha SP 150	Alpha SP 220	Alpha SP 320
Chevron / Texaco / Caltex	Meropa 100	Meropa 150 Ultra Gear 150	Meropa 220 Ultra Gear 220	Meropa 320 Ultra Gear 320
Citgo Petroleum Corp.	EP Compound 100	EP Compound 150	EP Compound 220	EP Compound 320
Exxon Mobil / Esso	Mobilgear 600 XP 100	Mobilgear 600 XP 150	Mobilgear 600 XP 220	Mobilgear 600 XP 320
Fuchs Lubricants Company	---	---	GearMaster CLP Oils 220	---
Kluber Lubrication	Kluberoil GEM 1 N 100	Kluberoil GEM 1 N 150	---	---
Petro-Canada Lubricants	Enduratex EP 100	Enduratex EP 150	Enduratex EP 220	Enduratex EP 320
Phillips 66 / Conoco / 76 Lubricants / Kendall	Extra Duty Gear Oil 100	Extra Duty Gear Oil 150	Extra Duty Gear Oil 220	Extra Duty Gear Oil 320
Shell Oil Co.	Omala S2 G 100	Omala S2 G 150	Omala S2 G 220	Omala S2 G 320
Total Lubricants USA / Keystone Div. Penwalt Corp.	Carter EP 100	Carter EP 150	Carter EP 220	Carter EP 320

[▲] Minimum viscosity index of 90.
 ■ Kinematic viscosity in units of mm²/s is equivalent to cSt (centistokes).

TABLE 5C — Petroleum Based Micropitting Resistant Lubricants [▲]
Maximum Operating Temperature of Lubricants 200°F (93°C)

ISO Viscosity Grade	100	150	220	320
AGMA Viscosity Grade	3	4	5	6
Viscosity cSt @ 40°C ■	90-110	135-165	198-242	288-352
Viscosity SSU @ 100°F	417-510	626-765	918-1122	1335-1632
Manufacturer	Lubricant Name	Lubricant Name	Lubricant Name	Lubricant Name
Kluber Lubrication	---	---	Kluberoil GEM 1 N 220	Kluberoil GEM 1 N 320

[▲] Minimum viscosity index of 90.
 ■ Kinematic viscosity in units of mm²/s is equivalent to cSt (centistokes).

TABLE 6A — Synthetic PAO (Polyalphaolefin) R & O (Rust & Oxidation) Inhibited Lubricants [▲]

ISO Viscosity Grade	32	68	150	220	320
AGMA Viscosity Grade	0	2	4	5	6
Viscosity cSt @ 40°C ■	28.8-35.2	61.2-74.8	135-165	198-242	288-352
Viscosity SSU @ 100°F	134-164	284-347	626-765	918-1122	1335-1632
Manufacturer	Lubricant Name	Lubricant Name	Lubricant Name	Lubricant Name	Lubricant Name
Castrol Industrial Lubricants	Alphasyn T 32	Alphasyn T 68	Alphasyn T 150	Alphasyn T 220	Alphasyn T 320
	Castrol Isolube 32	Castrol Isolube 68	Castrol Isolube 150	Castrol Isolube 220	Castrol Isolube 320
Chevron / Texaco / Caltex	Cetus HiPerSYN Oil 32	Cetus HiPerSYN Oil 68	Cetus HiPerSYN Oil 150	Cetus HiPerSYN Oil 220	Cetus HiPerSYN Oil 320
Citgo Petroleum Corp.	---	CITGEAR Synthetic HT 68	CITGEAR Synthetic HT 150	CITGEAR Synthetic HT 220	CITGEAR Synthetic HT 320
Exxon Mobil / Esso	Mobil SHC 624	Mobil SHC 626	Mobil SHC 629	Mobil SHC 630	Mobil SHC 632
Kluber Lubrication	---	Klubersynth G 4 68	Klubersynth G 4 150	Klubersynth G 4 220	---
Petro-Canada Lubricants	Synduro SHB 32	Synduro SHB 68	Synduro SHB 150	Synduro SHB 220	---
Phillips 66 / Conoco / 76 Lubricants / Kendall	---	Syncon R&O 68	Syncon R&O 150 ●	Syncon R&O 220 ●	Syncon R&O 320 ●
Shell Oil Co.	---	Morlina S4 B 68	Morlina S4 B 150	Morlina S4 B 220	Morlina S4 B 320

▲ Minimum viscosity index of 130. Consult lubricant supplier/manufacturer for maximum operating temperature.

■ Kinematic viscosity in units of mm²/s is equivalent to cSt (centistokes).

● Minimum viscosity index of 120.

TABLE 6B — Synthetic PAO (Polyalphaolefin) EP (Extreme Pressure) Lubricants [▲]

ISO Viscosity Grade	32	68	150	220	320
AGMA Viscosity Grade	0	2	4	5	6
Viscosity cSt @ 40°C ■	28.8-35.2	61.2-74.8	135-165	198-242	288-352
Viscosity SSU @ 100°F	134-164	284-347	626-765	918-1122	1335-1632
Manufacturer	Lubricant Name	Lubricant Name	Lubricant Name	Lubricant Name	Lubricant Name
Castrol Industrial Lubricants	---	Castrol Isolube EP 68	Alphasyn EP 150 Castrol Isolube EP 150	Alphasyn EP 220 Castrol Isolube EP 220	Alphasyn EP 320 Castrol Isolube EP 320
	---	---	Tegra Synthetic Gear Lubricant 150	Tegra Synthetic Gear Lubricant 220	Tegra Synthetic Gear Lubricant 320
Citgo Petroleum Corp.	---	CITGEAR Synthetic EP Gear 68	CITGEAR Synthetic EP Gear 150	CITGEAR Synthetic EP Gear 220	CITGEAR Synthetic EP Gear 320
Exxon Mobil / Esso	---	---	Mobil SHC Gear 150	Mobil SHC Gear 220	Mobil SHC Gear 320
Fuchs Lubricants Company	---	---	---	Renolin Unisyn CLP 220	Renolin Unisyn CLP 320
Kluber Lubrication	---	---	Klubersynth EG 4 150	Klubersynth EG 4 220	Klubersynth EG 4 320
Petro-Canada Lubricants	---	---	Enduratex Synthetic EP 150	Enduratex Synthetic EP 220	Enduratex Synthetic EP 320
Phillips 66 / Conoco / 76 Lubricants / Kendall	---	---	Syncon EP Plus Gear Oil 150	Syncon EP Plus Gear Oil 220	Syncon EP Plus Gear Oil 320
Shell Oil Co.	---	Omala S4 GX 68	Omala S4 GX 150	Omala S4 GX 220	Omala S4 GX 320
Whitmore Mfg. Company	---	---	Decathlon HD 150	Decathlon HD 220	Decathlon HD 320

▲ Minimum viscosity index of 130. Consult lubricant supplier/manufacturer for maximum operating temperature.

■ Kinematic viscosity in units of mm²/s is equivalent to cSt (centistokes).

TABLE 6C — Synthetic PAO (Polyalphaolefin) Micropitting Resistant Lubricants [▲]

ISO Viscosity Grade	32	68	150	220	320
AGMA Viscosity Grade	0	2	4	5	6
Viscosity cSt @ 40°C ■	28.8-35.2	61.2-74.8	135-165	198-242	288-352
Viscosity SSU @ 100°F	134-164	284-347	626-765	918-1122	1335-1632
Manufacturer	Lubricant Name	Lubricant Name	Lubricant Name	Lubricant Name	Lubricant Name
Chevron / Texaco / Caltex	---	---	---	---	Pinnacle WM 320
Exxon Mobil / Esso	---	---	---	---	Mobil SHC Gear 320 WT
Kluber Lubrication	---	---	Klubersynth GEM 4 N 150	Klubersynth GEM 4 N 220	Klubersynth GEM 4 N 320
Petro-Canada Lubricants	---	---	---	---	Harnex 320
Phillips 66 / Conoco / 76 Lubricants / Kendall	---	---	---	---	Syncon WTL 320
Whitmore Manufacturing Company	---	---	Decathlon F 150	Decathlon F 220	Decathlon F 320

▲ Minimum viscosity index of 130. Consult lubricant supplier/manufacturer for maximum operating temperature.

■ Kinematic viscosity in units of mm²/s is equivalent to cSt (centistokes).

PERIODICALLY — Carefully check the oil level of the drive when it is stopped and at ambient temperature, add oil if needed. If the oil level is ABOVE the high level mark on the dipstick, have the oil analyzed for water content. Moisture in the oil may indicate that the heat exchanger or a seal is leaking. If so, replace the defective part immediately and change the oil. DO NOT fill above mark indicated as leakage or undue heating may result. Also check coupling alignment to make certain that foundation settling has not caused excessive misalignment. If drive is equipped with a fan, periodically clean accumulated foreign matter from the fan, fan guard and deflector to allow adequate air flow.

LUBRICANT ANALYSIS AND CHANGES

OIL ANALYSIS REPORT — Checking oil condition at regular intervals is recommended. Analyze oil samples approximately every 1000 hours for petroleum lubricants or every 3000 hours for synthetic lubricants. In the absence of more specific limits, the guidelines listed below may be used to indicate when to change petroleum or polyalphaolefin type synthetic lubricants:

1. Water content is greater than 500 ppm (parts per million) (0.05%).
2. Iron content exceeds 150 ppm.
3. Silicon (dust/dirt) exceeds 25 ppm, above reference sample from new oil container.
4. Copper content exceeds 75 ppm.
5. TAN (Total Acid Number) 50% increase above reference sample from new oil container.
6. Viscosity changes more than ±15%.
7. Solid particle contamination code exceeds 25/22/18 for particle sizes ≥4/≥6/≥14 microns, respectively per ISO 4406.

Guidelines for when to change Falk GMax 6000 polyalkylene glycol type lubricant are:

1. Water content is greater than 3%.
2. Iron content exceeds 150 ppm.
3. Silicon (dust/dirt) exceeds 25 ppm, above reference sample from new oil container.
4. Copper content exceeds 75 ppm.
5. Viscosity changes more than ±15%.
6. Solid particle contamination code 25/22/18 per ISO 4406.

Laboratory analysis is recommended for optimum lubricant life and gear drive performance.

PETROLEUM LUBRICANTS — In the absence of oil analysis, change gear oils every 6 months or 2500 operating hours, whichever occurs first. Change oil more frequently when gear drives operate in extremely humid, chemical or dust laden atmospheres. In these cases, lubricants should be changed every 3 to 4 months or 1500 to 2000 hours. If the drive is operated in an area where temperatures vary with the seasons, change the oil viscosity grade to suit the temperature, refer to Table 3. Lubricant suppliers can test oil from the drive periodically and recommend economical change schedules.

SYNTHETIC LUBRICANTS — In the absence of oil analysis, synthetic lube change intervals can be extended to 8000 hours depending upon operating temperatures. Laboratory analysis is recommended for optimum lubricant life and drive performance. Change lube with change in ambient temperature, if required. Refer to Table 4.

Falk GMax 6000 change interval can be up to 15,000 hours. It has broad temperature range so seasonal oil changes are generally not needed. The condition of GMax must be monitored to maintain lubricant properties and cleanliness.

GREASE-LUBRICATED SEALS AND BEARINGS

Some gear drives have one or more grease lubricated bearings and grease purged seals. Gear drives and external backstops are shipped with NLGI #2 grade grease in the seal housing cavities and in those bearings requiring grease lubrication unless otherwise specified. Refer to Table 7 for grease recommendations.

GREASE LUBRICATED BEARINGS — Grease bearings during oil change intervals or every 6 months or 2500 hours of operation, whichever occurs first. Remove pressure relief plug when greasing bearing on vertical hollow shaft drives. Pump grease into bearing cage until it appears at the plug. Replace pressure relief plug

GREASE LUBRICATED SEALS — Most gear drives and backstops are furnished with grease purged seals which minimize the entry of contaminants and abrasive dusts into the drive or backstop. Grease seals during oil change intervals. Depending upon the degree of contamination, it may be necessary to purge contaminated grease from seals more often (at least every 3 to 6 months). Slowly pump fresh grease through the seal, **WITH HAND GREASE GUN**, until fresh grease flows out along the shaft. Wipe off purged grease.

CAUTION: Rapid regreasing with a power grease gun can force grease inward past the seals and plug the oil drain back system causing seal leaks.

TABLE 7 — Conventional NLGI #2 Grade Grease▲ for Grease Lubricated Bearings & Grease Purged Seals
0° to +200°F (-18° to +93°C)

Manufacturer	EP Lubricant for Gear Drive	Lubricant for Backstop Seals ■
Chevron / Texaco / Caltex	Multifak EP 2	---
Citgo Petroleum Corp.	Lithoplex RT 2 Premium Lithium EP 2	---
ExxonMobil / Esso	Mobilux EP 2 Mobilith SHC 460 ●	Unirex N2
Petro-Canada Lubricants	Precision General Purpose EP2	Precision XL EMB Grease Precision Synthetic EMB
Phillips 66 / Conoco / 76 Lubricants / Kendall	Multiplex Red	---
Shell Oil Co.	Gadus S1 V220-2	Gadus S2 V100-2
Total Lubricants USA / Keystone Div. Penwalt Corp.	Multis EP 2	Multis 2

- ▲ Not suitable for food grade applications.
- Caution: Do not use EP grease in external backstop purged seals.
- High performance synthetic alternate.

Grease application or re-lubrication should be done at temperatures above 20°F (-7°C). If grease must be applied at cooler temperatures consult lubricant supplier for recommendations.

TYPICAL SEAL ASSEMBLIES

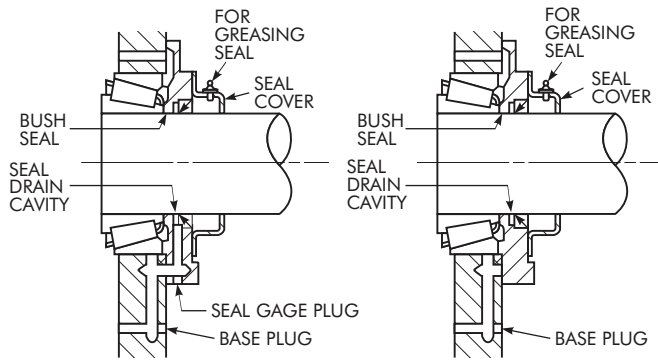

BACKSTOP EQUIPPED DRIVES — Type “Y” gear drives use a self contained, pawl type, backstop externally mounted on an intermediate shaft. These backstops contain two lube fittings, located on either side of the backstop, one for each purgeable seal. Grease seals during oil change intervals. Depending upon the degree of contamination, it may be necessary to purge contaminated grease from seals more often (at least every 3 to 6 months). Slowly pump fresh grease through the seal, **WITH HAND GREASE GUN**, until fresh grease flows out along the shaft. Wipe off purged excess grease. Be sure to perform this procedure for each lube fitting. **DO NOT** use greases with EP additives or other friction modifiers. Refer to the backstop manufacturer’s service manual (supplied with the drive) for detailed maintenance instructions.

WARNING: Greases in Table 7 contain harmful substances not allowed in the food processing industry. If grease could contaminate the product, as in the food and drug industries, the grease originally supplied with gear drive must be removed and replaced with grease listed in Table 15. Refer to gear drive assembly/disassembly instructions. Simply purging grease with grease gun will not remove all grease and cross-contamination will likely occur. Grease registered as H1 by NSF, National Sanitation Foundation, is suitable for food processing applications.

STORED & INACTIVE GEAR DRIVES

Each gear drive is protected with rust preventive that will protect parts against rust for a period of 4 months in an outdoor shelter or 12 months in a dry building after shipment from the Factory.

If a gear drive is to be stored, or is inactive after installation beyond the above periods, add Nox-Rust VCI-10 ▲ vapor-phase rust inhibitor. For drives that have oil installed, add Nox-Rust VCI-10 vapor-phase rust inhibitor at the rate of 2% of sump capacity as shown in Table 8. For drives without oil, add Nox-Rust VCI-10 vapor-phase rust inhibitor at the rate of one ounce per cubic foot of internal drive space. Rotate the shafts several times by hand. Before operating, drives which have been stored or inactive must be filled to the proper level with oil meeting the specifications given in this manual. Refer to Manual 128-014 for “Start-up after Storage” instructions.

▲ Product of the Daubert Chemical Company, Chicago, Illinois.

Periodically inspect stored or inactive gear drives and add Nox-Rust VCI-10 every six months, or more often if necessary. Indoor dry storage is recommended.

The vent cap and vented dipstick should be replaced with a plug (vent cap and vented dipstick should be attached to gear drive for future use) so that the protective rust inhibiting atmosphere is sealed inside the drive. Install vent cap and vented dipstick when preparing drive for operation.

WARNING: The rust preventative oil from the factory and Nox-Rust VCI-10 are not H1 registered with the NSF (National Sanitation Foundation) as suitable for food processing applications. When Food Grade Lubricants are to be used, it is the end users responsibility to properly flush and prepare the drive for Food Grade service. Contact the lubricant manufacturer for specific information and flushing procedures.

TABLE 8 — Nox-Rust VCI-10
(Add to stored or Inactive Drives with conventional gear lubricants)

Drive Size	NOX-RUST VCI-10	
	2% of Sump Capacity Gallons	2% of Sump Capacity Quarts
1080-1090, 2050-2090	0.3	1.4
1100-1135, 2100-2135	1.2	4.8
1140-1145, 2140-2145	1.7	6.8
1150-1165, 2150-2165	3.5	14.1
1170-1195, 2170-2195	7.9	31.4
2200-2235	22.7	90.9

FOOD GRADE LUBRICANTS

Guidance for selecting petroleum-based and synthetic-based food grade lubricants are shown below in Table 9. For general lubrication guidelines, refer to the first part of the "Lubrication Recommendation" Section.

FOOD GRADE LUBRICANT SELECTION PROCESS

1. Refer to Table 10 or 11 for proper lubricant viscosity grade based on ambient temperature range.
2. Refer to Table 9 for summary of food grade lubricant type.
3. Using proper food grade lubricant table and viscosity grade, select desired lubricant manufacturer name.
4. Refer to drive nameplate for approximate oil capacity to purchase.

TABLE 9 — Summary of Food Grade Lubricants and Greases

Petroleum-Based	
R & O Inhibited See Table 12A	Extreme Pressure (EP) See Table 12B
Synthetic Lubricant, Polyalphaolefin Type (PAO)	
R & O Inhibited See Table 13A	Extreme Pressure (EP) See Table 13B
Synthetic Lubricant, Polyalkylene Glycol Type (PAG)	
Extreme Pressure (EP) See Table 14	
Food Grade Grease	
See Table 15	

FOOD GRADE LUBRICANTS (TABLES 12A, 12B, 13A, 13B, 14 & 15) — Food grade lubricants are a class of lubricants registered as H1 by NSF, National Sanitation Foundation. They contain base stock and additives which comply with Food and Drug Administration Title 21 CFR 178.3570 regulations for lubricants with incidental food contact. Base stock can be petroleum oil or different types of synthetic lubricant. Food grade lubricants are not same as biodegradable or environmentally friendly lubricants. Rust and corrosion inhibitors used to protect gear drive during shipment are not qualified as food grade fluids. Flush out inhibitor oil before filling with food grade lubricant.

Tables 12A, 12B, 13A, 13B, 14 & 15 list food grade lubricants that have performance properties meeting Rexnord/Falk specifications. They are not exclusive recommendations but serve as a guide for making proper lubricant selections.

CLIMATE CONDITIONS — Ambient temperature in immediate vicinity of gear drive is very important for determining viscosity grade. Table 10 provides viscosity grade selections for petroleum-based lubricants. See Table 11 for synthetic lubricants.

Polyalkylene glycols (PAG) are another class of synthetic lubricants. They have similar performance properties as PAO synthetics - low pour point, stable at elevated temperatures, and high viscosity index. PAG's have exceptional tolerance to water contamination.

TABLE 10 — Viscosity Grade Recommendations For Food Grade Petroleum-Based Lubricants

Drive Description	Classification Symbol (Drive Type)	Drive Size	Normal Climates			
			+15° to +60°F (-9° to +16°C)		+50° to +125°F (+10° to +52°C)	
			ISO-VG	AGMA	ISO-VG	AGMA
Parallel Shaft and Horizontal Right Angle Roller Bearings Fabricated Steel Housings	Y1	50-135, 2050-2135	100	3	220	5
	YF1	1080-1135	100	3	220	5
	Y1	140-195, 2140-2165	150	4	220	5
	YF1	1140-1195	150	4	220	5
	Y2 & YB2 Y2 & YB2	50-195 2050-2245	150 150	4 4	220 220	5 5
Vertical Right Angle Fabricated Steel Housings	Y3, YB3 & 4 Y3, YB3 & 4	50-135, 2050-2135 140-195, 2140-2245	150 220	4 5	220 320	5 6
	Right Angle Horizontal and Vertical Cast Iron Housings	2000 GHB1	2050-2120	100	3	220
GHB		3-5	100	3	220	5
GDB		6-9	See Manual 128-010			
GRB		10-12				
GDX	4,5					
GDX, GRX	6-12					
Parallel Shaft Sleeve and Roller Bearings Cast Iron Housings	GHC, GHF	5	See Manual 128-010			
	GDA, GDF	6-9				
	GRA, GRF	10-13				
Parallel Shaft Semi-high Speed Sleeve, Roller and Ball Bearings	YHF1	1080-1135	See Manual 128-010			
	YH1	2050-2125				
	YH2	2050-2175				
	GHCH	5				
	GHCH	6-13				
Parallel Shaft High Speed Sleeve Bearings	YQA, YPA	All Sizes	See Manual 128-010			

OIL PUMPS — When selecting a lubricant for a gear drive equipped with an oil pump, cold temperature oil viscosity is important. Lubricant viscosity at start-up generally should not exceed 1725 cSt (8,000 SSU). When exceeding this viscosity, pump cavitation is possible, preventing oil circulation. A sump heater may be required or it may be possible to use a lower viscosity oil to minimize pump cavitation.

TABLE 11 — Viscosity Grade Recommendations for Food Grade Synthetic Lubricants

Ambient Temperature Range	Cold Climates		Normal Climates		
	-30° to +10°F (-34° to -12°C)	-15° to +50°F (-26° to +10°C)	0° to +80°F (-18° to +27°C)	+10° to +125°F (-12° to +52°C)	+20° to +125°F (-7° to +52°C)
ISO Viscosity Grade	32	68	150	220	320
AGMA Viscosity Grade	0	2	4	5	6

TABLE 12A — Food Grade Petroleum-Based R & O (Rust & Oxidation) Inhibited Lubricants — NSF (National Sanitation Foundation) H1 Registered
 Maximum operating temperature of lubricants 200°F (93°C)

ISO Viscosity Grade	100	150	220	320
AGMA Viscosity Grade	3	4	5	6
Viscosity cSt @ 40°C ▲	90-110	135-165	198-242	288-352
Viscosity SSU @ 100°F	417-510	626-765	918-1122	1335-1632
Manufacturer	Lubricant Name	Lubricant Name	Lubricant Name	Lubricant Name
Bel-Ray Company, Inc.	---	No-Tox Gear Oil ISO 150	No-Tox Gear Oil ISO 220	No-Tox Gear Oil ISO 320
Kluber Lubrication	Paraliq P 100	Paraliq P 150	---	---
Lubriplate Lubricants Co.	Lubriplate FMO 500-AW	Lubriplate FMO 900-AW	Lubriplate FMO 1100-AW	Lubriplate FMO 1700-AW

▲ Kinematic viscosity in units of mm²/S is equivalent to cSt (centistokes)

TABLE 12B — Food Grade Petroleum-Based EP (Extreme Pressure) Lubricants — NSF (National Sanitation Foundation) H1 Registered
 Maximum operating temperature of lubricants 200°F (93°C)

ISO Viscosity Grade	100	150	220	320
AGMA Viscosity Grade	3	4	5	6
Viscosity cSt @ 40°C ▲	90-110	135-165	198-242	288-352
Viscosity SSU @ 100°F	417-510	626-765	918-1122	1335-1632
Manufacturer	Lubricant Name	Lubricant Name	Lubricant Name	Lubricant Name
Petro-Canada	Purity FG EP 100	Purity FG EP 150	Purity FG EP 220	Purity FG EP 320
Total Lubricants USA, Inc.	Nevastane EP 100	Nevastane EP 150	Nevastane EP 220	Nevastane EP 320

▲ Kinematic viscosity in units of mm²/S is equivalent to cSt (centistokes)

TABLE 13A — Food Grade Synthetic PAO (Polyalphaolefin) R & O (Rust & Oxidation) Inhibited Lubricants — NSF (National Sanitation Foundation) H1 Registered
 Maximum operating temperature of lubricants 200°F (93°C)

ISO Viscosity Grade	32	68	150	220	320
AGMA Viscosity Grade	0	2	4	5	6
Viscosity cSt @ 40°C ▲	28.2-35.2	61.2-74.8	135-165	198-242	288-352
Viscosity SSU @ 100°F	134-164	284-347	626-765	918-1122	1335-1632
Manufacturer	Lubricant Name	Lubricant Name	Lubricant Name	Lubricant Name	Lubricant Name
ExxonMobil	Mobil SHC Cibus 32	Mobil SHC Cibus 68	Mobil SHC Cibus 150	Mobil SHC Cibus 220	Mobil SHC Cibus 320
Kluber Lubrication	Kluberoil 4 UH1 N 32	Kluberoil 4 UH1 N 68	Kluberoil 4 UH1 N 150	Kluberoil 4 UH1 N 220	Kluberoil 4 UH1 N 320
Lubriplate Lubricants Co.	Lubriplate SFGO Ultra 32	Lubriplate SFGO Ultra 68	Lubriplate SFGO Ultra 150	Lubriplate SFGO Ultra 220	Lubriplate SFGO Ultra 320
Total Lubricants USA, Inc.	Nevastane SL 32	Nevastane SL 68	Nevastane SL 150	Nevastane SL 220	Nevastane SL 320

▲ Kinematic viscosity in units of mm²/S is equivalent to cSt (centistokes)

TABLE 13B — Food Grade Synthetic PAO (Polyalphaolefin) EP (Extreme Pressure) Lubricants — NSF (National Sanitation Foundation) H1 Registered
 Maximum operating temperature of lubricants 200°F (93°C)

ISO Viscosity Grade	32	68	150	220	320
AGMA Viscosity Grade	0	2	4	5	6
Viscosity cSt @ 40°C ▲	28.8-35.2	61.2-74.8	135-165	198-242	288-352
Viscosity SSU @ 100°F	134-164	284-347	626-765	918-1122	1335-1632
Manufacturer	Lubricant Name	Lubricant Name	Lubricant Name	Lubricant Name	Lubricant Name
Petro-Canada	---	---	---	Purity FG Synthetic EP 220	---

▲ Kinematic viscosity in units of mm²/S is equivalent to cSt (centistokes)

TABLE 14 — Food Grade Synthetic PAG (Polyalkylene Glycol) EP (Extreme Pressure) Lubricants — NSF (National Sanitation Foundation) H1 Registered
Maximum operating temperature of lubricants 200°F (93°C)
See Warning Note below.

ISO Viscosity Grade	32	68	150	220	320
AGMA Viscosity Grade	0	2	4	5	6
Viscosity cSt @ 40°C ▲	28.8-35.2	61.2-74.8	135-165	198-242	288-352
Viscosity SSU @ 100° F	134-164	284-347	626-765	918-1122	1335-1632
Manufacturer	Lubricant Name	Lubricant Name	Lubricant Name	Lubricant Name	Lubricant Name
Exxon Mobil	---	---	Glygoyle 150	Glygoyle 220	Glygoyle 320
Kluber Lubrication	---	---	Klubersynth UH1 6-150	Klubersynth UH1 6-220	Klubersynth UH1 6-320
Lubriplate	---	---	PGO-FGL Synthetic Gear Oil 150	PGO-FGL Synthetic Gear Oil 220	PGO-FGL Synthetic Gear Oil 320

WARNING: Polyalkylene glycol (PAG) lubricants are not compatible with petroleum mineral oils or PAO synthetic lubricants. PAG's must not be mixed or used to top off either petroleum mineral oils or PAO synthetic lubricants.

▲ Kinematic viscosity in units of mm²/s is equivalent to cSt (centistokes)

WARNING: Polyalkylene glycols (PAG's) are not compatible with petroleum mineral oil or PAO synthetic lubricants and must not be topped off with either lubricant. In addition, petroleum mineral oils or PAO synthetic lubricants must not be used to top off systems containing PAG's. Do not use PAG's in gear drives with painted interior housing walls unless paint compatibility is checked. Compatibility with oil seals and gasket materials must be checked prior to use. PAG lubricants are not compatible with polycarbonate sight glass. Use glass sight glass.

PREVENTIVE MAINTENANCE

AFTER FIRST WEEK — Check alignment of the total system and realign where necessary. Also, tighten all external bolts and plugs where necessary. DO NOT readjust the internal gear or bearing settings in the drive, these were permanently set at the Factory.

OIL FILTER SERVICE — Record oil pressure at oil filter indicating gauge with drive at operating temperature, with fresh oil. Replace oil filter when oil pressure INCREASE reaches 10 psi with drive at operating temperature. Replacement filter elements (Falk Part No. 10092262, Gresen K-22002 or equivalent 30 micron) are available from the Factory.

AFTER FIRST MONTH'S SERVICE — Proceed as follows:

1. Operate drive until old sump oil reaches normal operating temperature. Shut the drive down and drain immediately.
2. Immediately flush drive with a food grade oil of the same type and viscosity grade as the original charge (warmed to approximately 100°F (38°C) in cold weather). Rapidly pour or pump a charge equal to 25-100% of the initial fill volume through the drive or until clean oil flows through the drain.
3. Close the drain and refill the drive to the correct level with new food grade oil of the correct type and viscosity.

PERIODICALLY — Carefully check the oil level of the drive when it is stopped and at ambient temperature, add oil if needed. If the oil level is ABOVE the high level mark on the dipstick, have the oil analyzed for water content. Moisture in the oil may indicate that the heat exchanger or a seal

is leaking. If so, replace the defective part immediately and change the oil. DO NOT fill above mark indicated as leakage or undue heating may result. Also check coupling alignment to make certain that foundation settling has not caused excessive misalignment. If drive is equipped with a fan, periodically clean accumulated foreign matter from the fan, fan guard and deflector to allow adequate air flow.

LUBRICANT ANALYSIS AND CHANGES

OIL ANALYSIS REPORT (FOOD GRADE) — Checking oil condition at regular intervals is recommended. Analyze oil samples approximately every 1000 hours for food grade petroleum lubricants or every 3000 hours for food grade synthetic lubricants. In the absence of more specific limits, the guidelines listed below may be used to indicate when to change food grade lubricants:

1. Water content is greater than 500 ppm (parts per million) (0.05%).
2. Iron content exceeds 150 ppm.
3. Silicon (dust/dirt) exceeds 25 ppm, above reference sample from new oil container.
4. Copper content exceeds 75 ppm.
5. TAN (Total Acid Number) 50% increase above reference sample from new oil container.
6. Viscosity changes more than ±15%.
7. Solid particle contamination code exceeds 25/22/18 for particle sizes ≥4/≥6/≥14 microns, respectively per ISO 4406.

Guidelines for when to change food grade polyalkylene glycol type lubricant are:

1. Water content is greater than 3%.
2. Iron content exceeds 150 ppm.
3. Silicon (dust/dirt) exceeds 25 ppm, above reference sample from new oil container.
4. Copper content exceeds 75 ppm.
5. Viscosity changes more than ±15%.
6. Solid particle contamination code 25/22/18 per ISO 4406.

Laboratory analysis is recommended for optimum lubricant life and gear drive performance.

PETROLEUM LUBRICANTS (FOOD GRADE) — In the

absence of oil analysis, change gear oils every 6 months or 2500 operating hours, whichever occurs first. Change oil more frequently when gear drives operate in extremely humid, chemical or dust laden atmospheres. In these cases, lubricants should be changed every 3 to 4 months or 1500 to 2000 hours. If the drive is operated in an area where temperatures vary with the seasons, change the oil viscosity grade to suit the temperature, refer to Table 10. Lubricant suppliers can test oil from the drive periodically and recommend economical change schedules.

SYNTHETIC LUBRICANTS (FOOD GRADE) — In the absence of oil analysis, synthetic lube change intervals can be extended to 8000 hours depending upon operating temperatures. Laboratory analysis is recommended for optimum lubricant life and drive performance. Change lube with change in ambient temperature, if required. Refer to Table 11.

GREASE-LUBRICATED SEALS AND BEARINGS

Some gear drives have one or more grease lubricated bearings and grease purged seals. Gear drives and external backstops are shipped with NLGI #2 grade grease in the seal housing cavities and in those bearings requiring grease lubrication unless otherwise specified.

GREASE LUBRICATED BEARINGS — Grease bearings during oil change intervals or every 6 months or 2500 hours of operation, whichever occurs first, with one of the food grade greases listed in Table 15. Remove pressure relief plug when greasing bearing on vertical hollow shaft drives. Pump grease into bearing cage until it appears at the plug. Replace pressure relief plug

GREASE LUBRICATED SEALS — Most gear drives and backstops are furnished with grease purged seals which minimize the entry of contaminants and abrasive dusts into the drive or backstop. Grease seals during oil change intervals with one of the food grade greases listed in Table 15. Depending upon the degree of contamination, it may be necessary to purge contaminated grease from seals more often (at least every 3 to 6 months). Slowly pump

TABLE 15 — Food Grade Grease[▲] for Grease Lubricated Bearings & Grease Purged Seals, NLGI #2 Grade
0° to +200°F (-18° to +93°C)

Manufacturer	Lubricant
Bel-Ray Company, Inc.	No-Tox HD Grease 2
Chevron USA, Inc. (Texaco/Caltex)	Chevron FM ALC EP 2
Exxon Mobil	Mobil SHC Polyrex 462
Kluber Lubrication	Klubersynth UH1 14-222
Lubriplate	Lubriplate FGL-2
Total Lubricants USA, Inc.	Nevastane HT/AW 2
Petro-Canada	Purity FG
Phillips 66 / Conoco / 76 Lubricants / Kendall	Food Machinery Grease 2

[▲] NSF (National Sanitation Foundation) H1 Registered.

Grease application or re-lubrication should be done at temperatures above 20°F (-7°C). If grease must be applied at cooler temperatures consult lubricant supplier for recommendations.

TYPICAL SEAL ASSEMBLIES

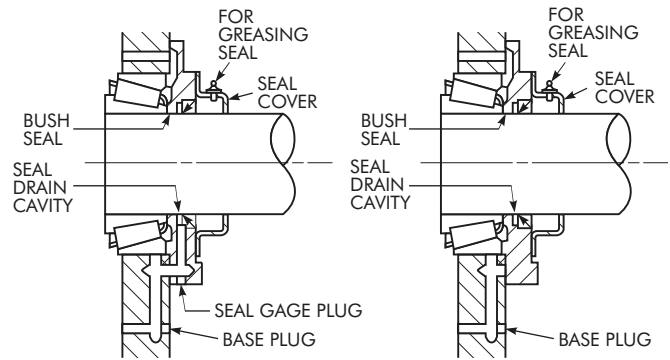

fresh grease through the seal, **WITH HAND GREASE GUN**, until fresh grease flows out along the shaft. Wipe off purged grease.

CAUTION: Rapid regreasing with a power grease gun can force grease inward past the seals and plug the oil drain back system causing seal leaks.

BACKSTOP EQUIPPED DRIVES — Type “Y” gear drives use a self contained, pawl type, backstop externally mounted on an intermediate shaft. These backstops contain two lube fittings, located on either side of the backstop, one for each purgeable seal. Grease seals during oil change intervals with one of the food grade greases listed in Table 15. Depending upon the degree of contamination, it may be necessary to purge contaminated grease from seals more often (at least every 3 to 6 months). Slowly pump fresh grease through the seal, **WITH HAND GREASE GUN**, until fresh grease flows out along the shaft. Wipe off purged excess grease. Be sure to perform this procedure for each lube fitting. Refer to the backstop manufacturer’s service manual (supplied with the drive) for detailed maintenance instructions.

If grease could contaminate the product, as in the food and drug industries, the grease originally supplied with gear drive must be removed and replaced with grease listed in Table 15. Refer to gear drive assembly/disassembly instructions. Simply purging grease with grease gun will not remove all grease and cross-contamination will likely occur. Grease registered as H1 by NSF, National Sanitation Foundation, is suitable for food processing applications.

STORED & INACTIVE GEAR DRIVES

Prior to shipment from the factory, all Rexnord enclosed gear drives are protected internally against corrosion with a rust preventative oil. A vapor phase rust inhibitor may also be added.

WARNING: These corrosion inhibitors are not H1 registered with the NSF (National Sanitation Foundation) as suitable for food processing applications. When Food Grade Lubricants are to be used, it is the end users responsibility to properly flush and prepare the drive for Food Grade service. Contact the lubricant manufacturer