

**FLYWHEEL END**  
**Engine**  
**(Waukesha 16V275GL)**  
**28.875 in - LD**

**HUB END**  
**Compressor**  
**(Ariel JGC/6)**  
**KEYWAY NONE**

A. TORSIONAL DATA (CALC.)  
 WT = 1346.6 lbs [ 610.8 kg]  
 $WR^2 = 108951.3 \text{ lbs-in}^2 [31.88 \text{ kg-m}^2]$   
 $Kt = 3.31E^{\wedge}8 \text{ in-lbs/rad} [3.74E^{\wedge}7 \text{ Nm/rad}]$   
 (BASED ON 1/3 SHAFT PENETRATION FACTOR IN HUB)

B. COUPLING TORQUE RATINGS  
 MAXIMUM CONTINUOUS = 1281280 in-lbs [144647 Nm]  
 PEAK OVERLOAD = 1537536 in-lbs [173576 Nm]

C. OPERATING DATA  
 POWER = 4835 HP [3605.5 kW]  
 SPEED = 1000 RPM  
 TORQUE = 304726 in-lbs [34432.5 Nm]  
 SERVICE FACTOR = 4.2

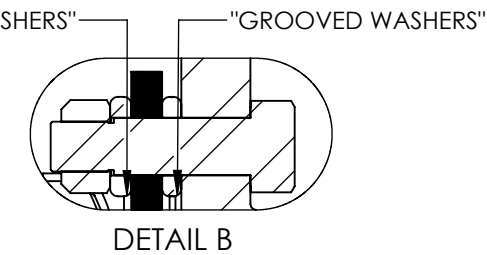
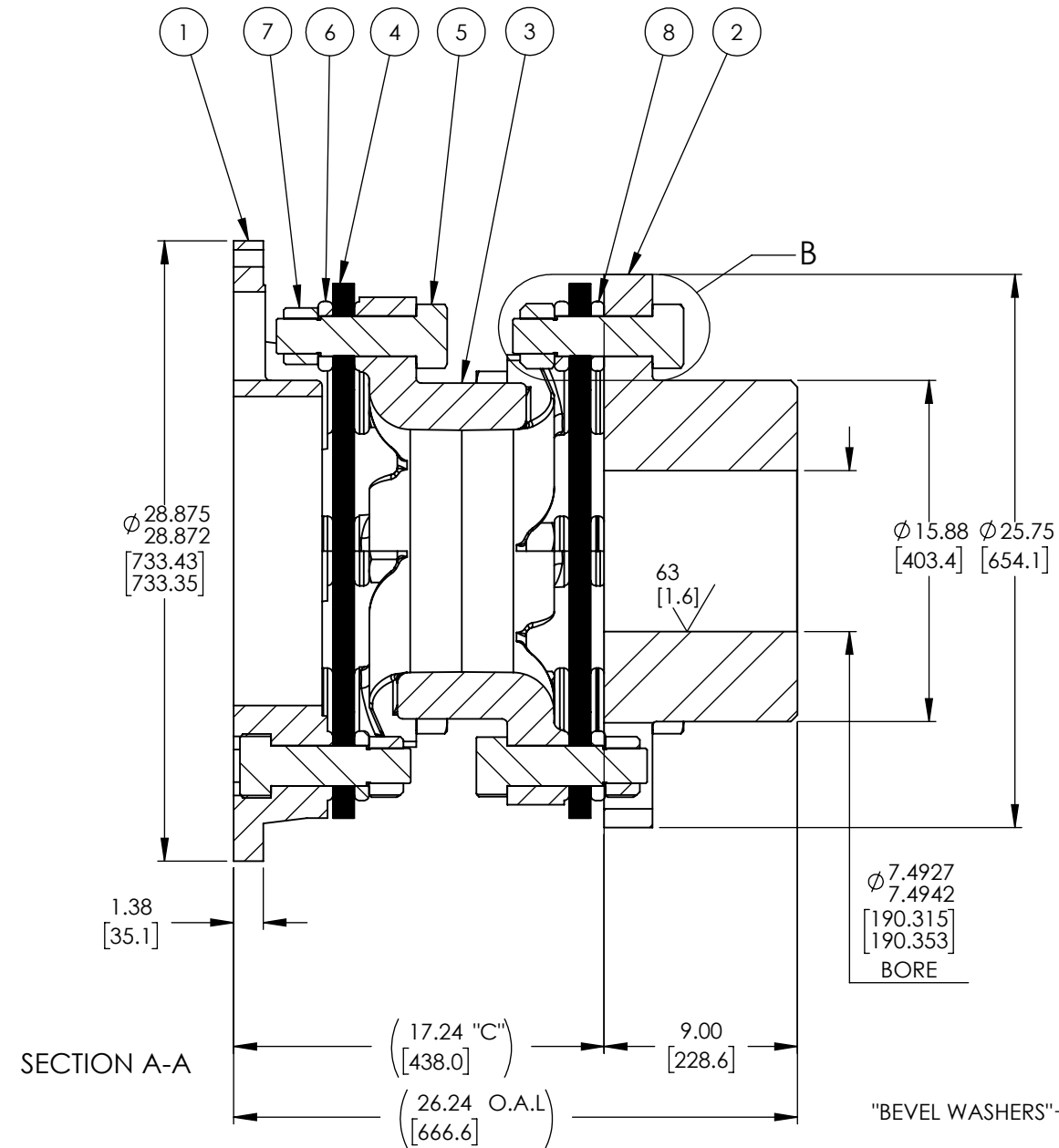
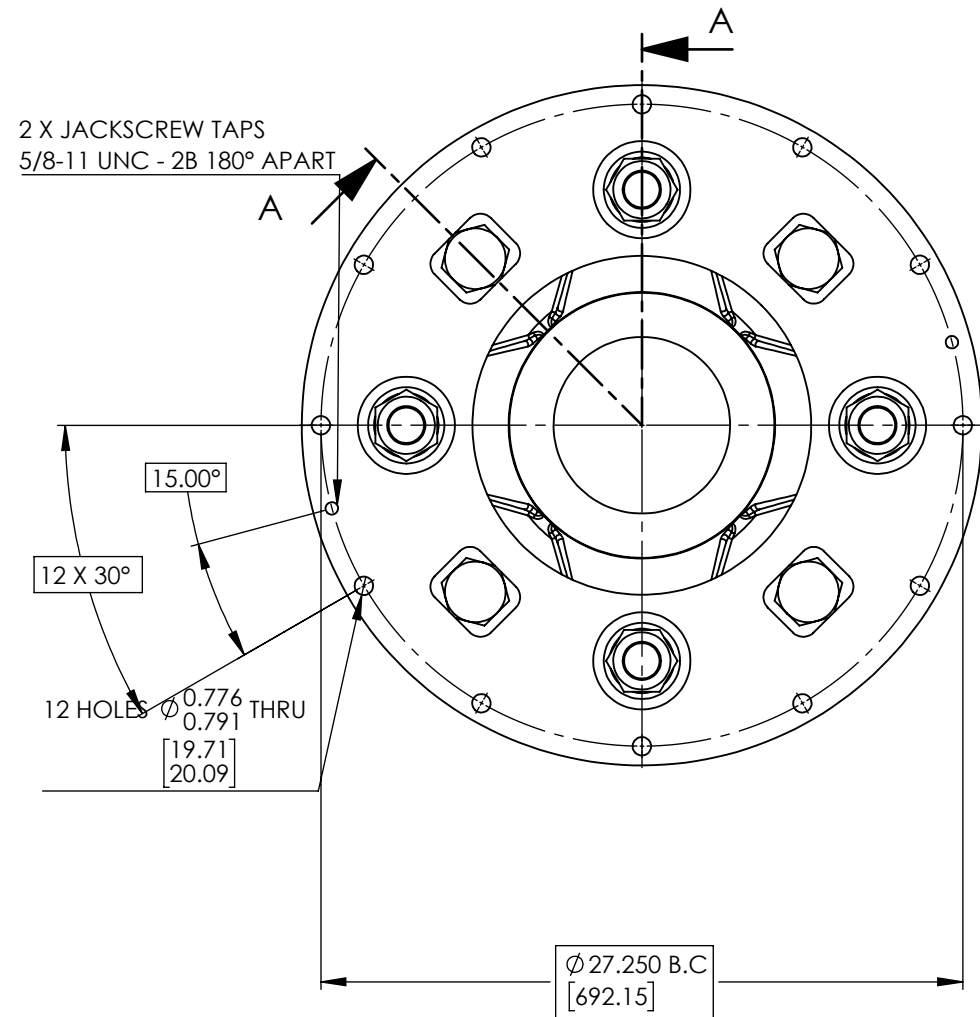

REFERENCE ONLY:  
 SHAFT SIZE:  $\phi 7.5000/7.4990 [190.500/190.475]$   
 RESULTING SHAFT/BORE INTERFERENCE FIT=  $0.0048/0.0073 [0.122/0.185]$   
 AVAILABLE SHAFT LENGTH=  $9.00 [228.6]$

**ASSEMBLY CAUTION NOTE:**

IT IS IMPORTANT THAT ALL LOOSE WASHERS ARE INSTALLED IN THEIR CORRECT POSITION:  
 \* THE 4 "GROOVED WASHERS" MUST BE INSTALLED BETWEEN HUB FLANGE FACE AND DISC PACK AS SHOWN - SEE "DETAIL B",  
 \* THE 16 "BEVEL WASHERS" MUST BE INSTALLED ON ALL FLEX JOINT BOLTS (ONE UNDER EACH LOCKNUT) AS SHOWN - SEE "DETAIL B".

ITEM NO.	PART NUMBER	DESCRIPTION	QTY.	MATERIAL	COMMENTS
8	56641	GROOVE WASHER	4	1144 SRA 100 STRESSPROOF	"SEE ASSEMBLY CAUTION NOTE"
7	13898	LOCKNUT	16	IFI GRADE C	
6	11043	BEVEL WASHER	16	1144 SRA 100 STRESSPROOF	"SEE ASSEMBLY CAUTION NOTE"
5	13897	BOLT	16	SAE GRADE 8	
4	20958	DISC PACK	2	TOMALOY	LAMINATION THK.: 0.984/1.014 [24.99/25.76]
3	20956	CENTERMEMBER	1	ASTM A-27-65 CLASS 70-36 (CAST STEEL)	
2	57132	HUB	1	AISI 1146 OR 1141 OR 1045	
1	52449-01	ADAPTER	1	DUCTILE IRON	

REVISIONS		THIS DOCUMENT CONTAINS CONFIDENTIAL/PROPRIETARY INFORMATION OF REXNORD INDUSTRIES, LLC. NEITHER RECEIPT NOR POSSESSION THEREOF CONFERS ANY OWNERSHIP INTEREST IN RIGHT TO REPRODUCE OR USE, OR DISCLOSE IN WHOLE OR IN PART, ANY SUCH INFORMATION WITHOUT WRITTEN AUTHORIZATION FROM REXNORD INDUSTRIES, LLC. IT IS SUBJECT TO RETURN UPON DEMAND. THESE COMMODITIES, TECHNOLOGY, OR SOFTWARE ARE SUBJECT TO THE UNITED STATES EXPORT REGULATIONS. DIVERSION CONTRARY TO U.S. LAW AND OTHER RELEVANT EXPORT CONTROLS IS PROHIBITED.		 WWW.REXNORD.COM <b>THOMAS</b> Flexible Couplings	
THIRD ANGLE PROJECTION	INCH [mm]	DR. DRV_WRKS	1/2/2023	COUPLING ASSEMBLY	DRAWING NO. S00117027
		CHK.		925 CMR	REV. -
				STANDARD	SAP MTL 10402565
					ORDER NO. SHEET 1 OF 1