

**FLYWHEEL END
Engine
(CAT 3612)
28.875 in - HD**

**HUB END
Compressor
(Ariel JGC/4)
KEYWAY NONE**

- A. TORSIONAL DATA (CALC.)
 WT = 1375.5 lbs [623.9 kg]
 WR² = 109241.2 lbs-in² [31.97 kg-m²]
 Kt = 2.82E⁸ in-lbs/rad [3.18E⁷ Nm/rad]
 (BASED ON 1/3 SHAFT PENETRATION FACTOR IN HUB)
- B. COUPLING TORQUE RATINGS
 MAXIMUM CONTINUOUS = 1281280 in-lbs [144647 Nm]
 PEAK OVERLOAD = 1537536 in-lbs [173576 Nm]
- C. OPERATING DATA
 POWER = 3750 HP [2796.4 kW]
 SPEED = 1000 RPM
 TORQUE = 236344 in-lbs [26705.6 Nm]
 SERVICE FACTOR = 5.42

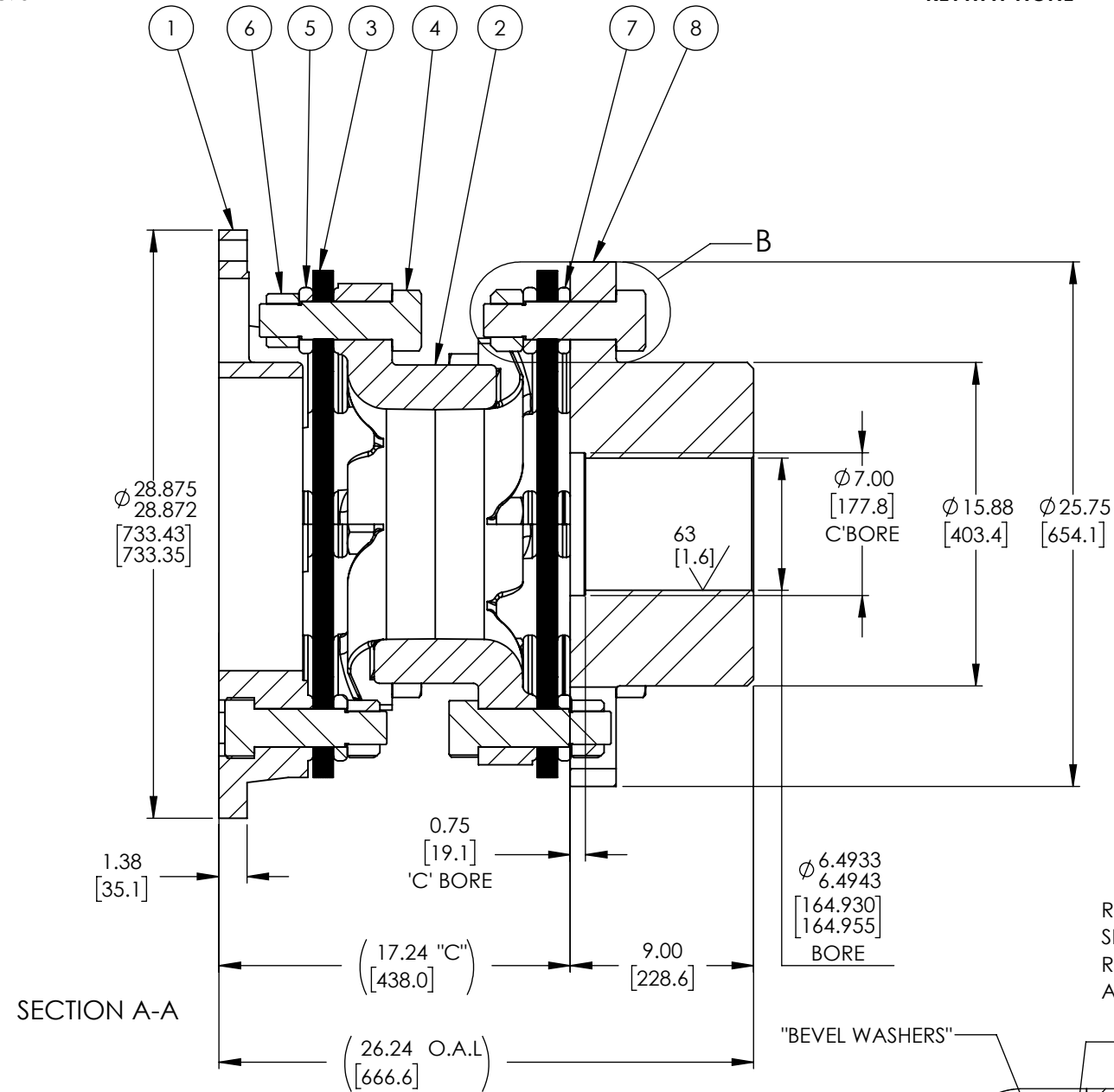
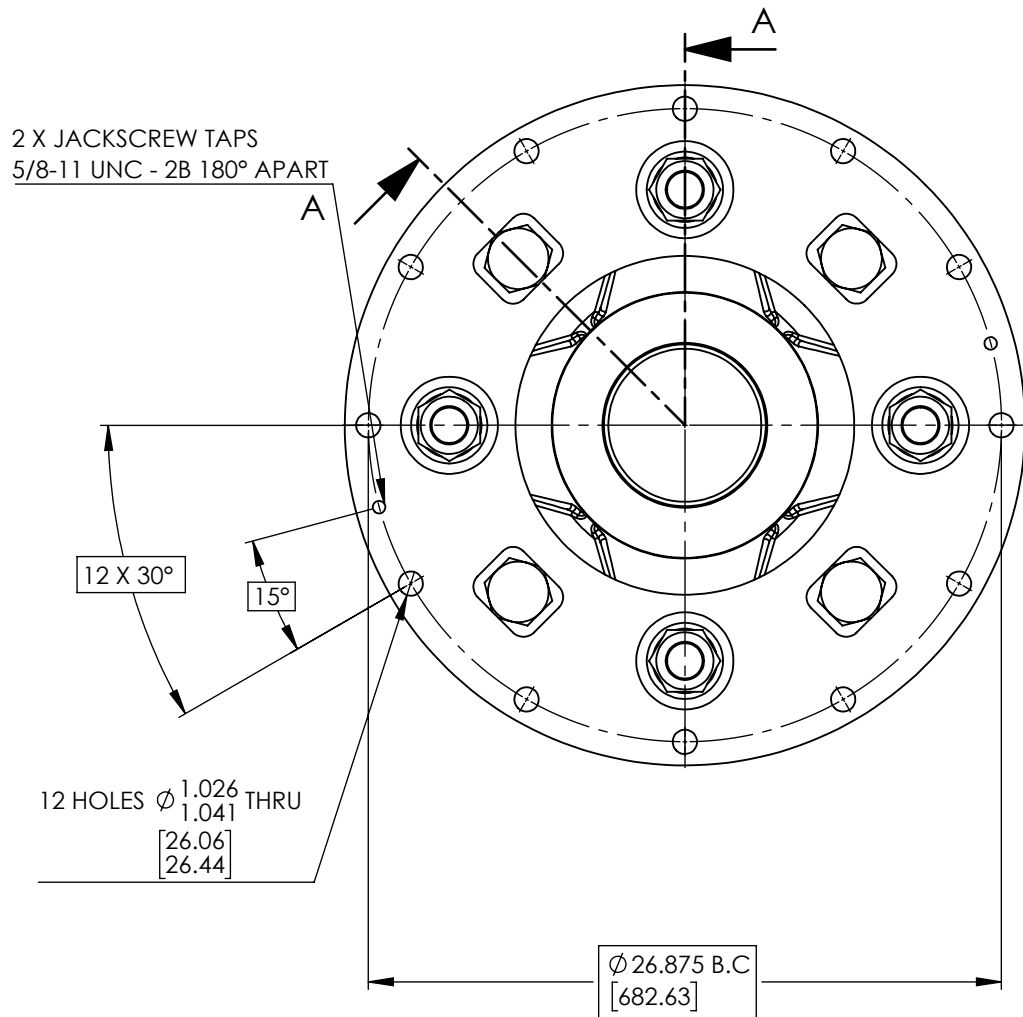

REFERENCE ONLY:
 SHAFT SIZE: Ø 6.5000/6.4990 [165.100/165.075]
 RESULTING SHAFT/BORE INTERFERENCE FIT= 0.0067/0.0047 [0.170/0.119]
 AVAILABLE SHAFT LENGTH= 8.250 [209.55]

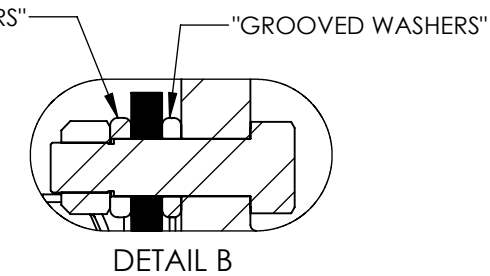

ASSEMBLY CAUTION NOTE:

IT IS IMPORTANT THAT ALL LOOSE WASHERS ARE INSTALLED IN THEIR CORRECT POSITION:
 * THE 4 "GROOVED WASHERS" MUST BE INSTALLED BETWEEN HUB FLANGE FACE AND DISC PACK AS SHOWN - SEE "DETAIL B",
 * THE 16 "BEVEL WASHERS" MUST BE INSTALLED ON ALL FLEX JOINT BOLTS (ONE UNDER EACH LOCKNUT) AS SHOWN - SEE "DETAIL B".

MOUNTING DIMENSIONS:
 DUE TO THE SELECTION OF THE COUNTERBORE, YOUR MOUNTING DIMENSION MAY BE THE "C" SHOWN PLUS YOUR COUNTERBORE DEPTH.
 CONSULT ENGINEERING IF NEEDED.

ITEM NO.	PART NUMBER	DESCRIPTION	QTY.	MATERIAL	COMMENTS
8	83654-01	HUB	1	AISI 4140 OR 4340	
7	56641	GROOVE WASHER	4	1144 SRA 100 STRESSPROOF	"SEE ASSEMBLY CAUTION NOTE"
6	13898	LOCKNUT	16	IFI GRADE C	
5	11043	BEVEL WASHER	16	1144 SRA 100 STRESSPROOF	"SEE ASSEMBLY CAUTION NOTE"
4	13897	BOLT	16	SAE GRADE 8	
3	20958	DISC PACK	2	TOMALOY	LAMINATION THK.: 0.984/1.014 [24.99/25.76]
2	20956	CENTERMEMBER	1	ASTM A-27-65 CLASS 70-36 (CAST STEEL)	
1	52449-02	ADAPTER	1	DUCTILE IRON	

REVISIONS	

THIS DOCUMENT CONTAINS CONFIDENTIAL/PROPRIETARY INFORMATION OF REXNORD INDUSTRIES, LLC. NEITHER RECEIPT NOR POSSESSION THEREOF CONFERS ANY OWNERSHIP INTEREST IN RIGHT TO REPRODUCE OR USE, OR DISCLOSE IN WHOLE OR IN PART, ANY SUCH INFORMATION WITHOUT WRITTEN AUTHORIZATION FROM REXNORD INDUSTRIES, LLC. IT IS SUBJECT TO RETURN UPON DEMAND. THESE COMMODITIES, TECHNOLOGY, OR SOFTWARE ARE SUBJECT TO THE UNITED STATES EXPORT REGULATIONS. DIVERSION CONTRARY TO U.S. LAW AND OTHER RELEVANT EXPORT CONTROLS IS PROHIBITED.

DR. DRV_WRKS 10/4/2022
 CHK. _____

REXNORD
 COUPLING GROUP
 WWW.REXNORD.COM

THOMAS
 Flexible Couplings

COUPLING ASSEMBLY
 925 CMR
 STANDARD

DRAWING NO. S00109990	REV. -
SAP MTL 10732711	SHEET 1 OF 1
ORDER NO.	