

CENTA-CP®

Clutch Pack

Clutch Pack in flange housing with
integrated clutch and torsional coupling

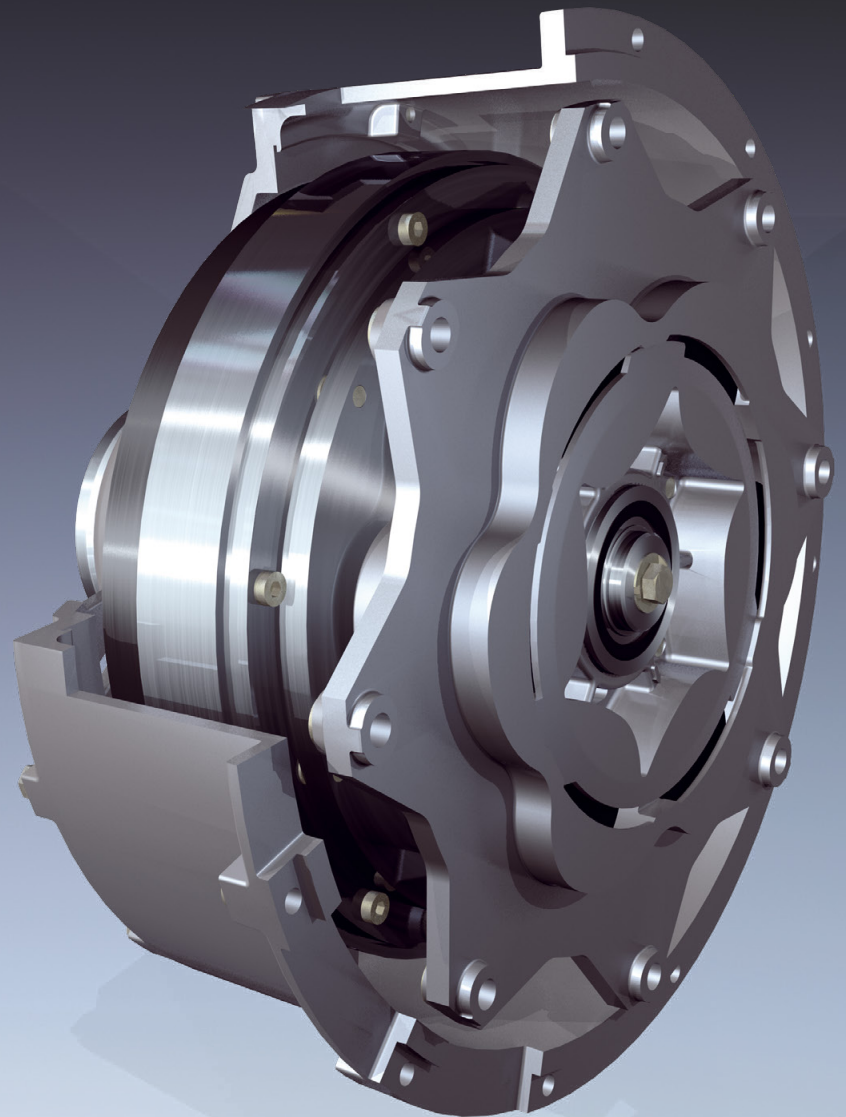

CENTA-CP Integrated Clutch-Coupling-Pack

This is an engineered combination of three reliable and well tried components, designed for a Diesel engine drive whether it shall be engaged or disengaged.

The CENTA-CP comprises:

- The CENTAFLEX-R, a tough, reliable, torsional coupling with progressive characteristic and bolted to the fly-wheel. This coupling takes care of the torsional vibrations and misalignments whilst protecting the whole drive train against dangerous torsional vibrations.
- The CENTAMAX, a torsional coupling with linear characteristic, is optionally also available if the torsional situation should require such coupling.
- A simple robust, dry running electro magnetic pole-face friction clutch for engaging and disengaging.
- A proven CENTA-FH flanged bearing housing with output shaft supported by tapered roller bearings. The output flange of the CENTA-CP is compatible with DIN or SAE flanges for connection to the driven equipment by universal joint or other power transmission components. Please see page 7 for possible arrangements.

Typical areas of application:

- Ship propulsion with propellers, waterjets, stern drives, thrusters, pumping sets, generators, etc.

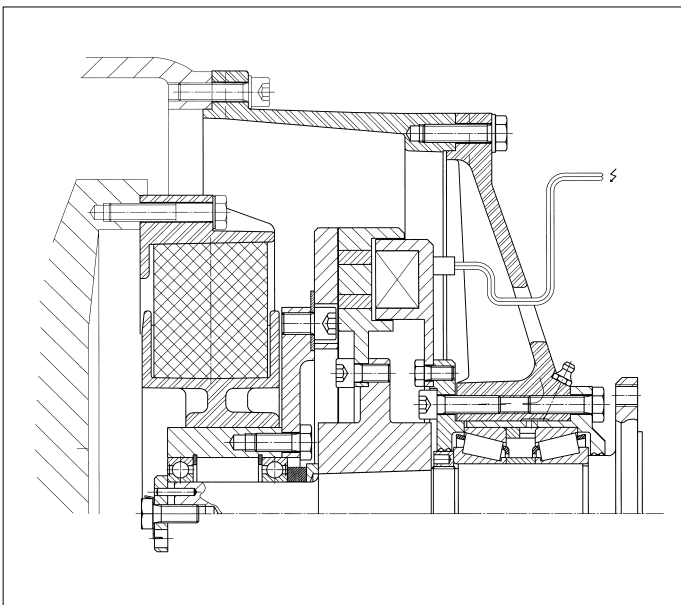

Selection:

● CENTAFLEX-R

Selection is based on nominal torque transmission. The technical data and ratings are shown on page 4 and with more detailed information on data sheet D26-003. No additional service factor is required for this flexible coupling.

The responsibility for ensuring torsional compatibility rests with the assembler of the drive train. CENTA cannot accept liability for noise or damage to the coupling or associated machinery caused by torsional vibrations.

● Clutch

Description on page 5

The nominal torque rating (T_{KC}) of the clutch is the torque that it can transmit after full engagement, ie without slip between driving and driven member and with run-in condition and dry operation.

During engagement the transmittable torque is lower, please refer to the diagram on page 5.

The nominal clutch torque [T_{KC}] can be applied with a service factor of 1 for smooth running applications, where the engagement happens at low idling speed (about 600-700 rpm) and where the power absorption of the driven equipment is proportionally low and the driven inertia is moderate.

Typical examples: propellers, jets, pumps and other drives where the absorbed torque follows the propeller law.

For heavier duties reasonable service factors of 1.25 up to 2.4 must always be applied.

Engineers at CENTA will be pleased to assist in the selection of the correct unit where there is any doubt, or where exceptional application details exist.

● CENTA-FH bearing housing

Description on page 6

The standard taper roller bearing pack is designed for commonly used speeds, a service life in excess of 20,000 hrs and a universal joint angle up to about 6 degrees.

Please consult CENTA if your application exceeds the above or if a pulley with high side load shall be driven, we can provide a special bearing arrangement.

Dimensions

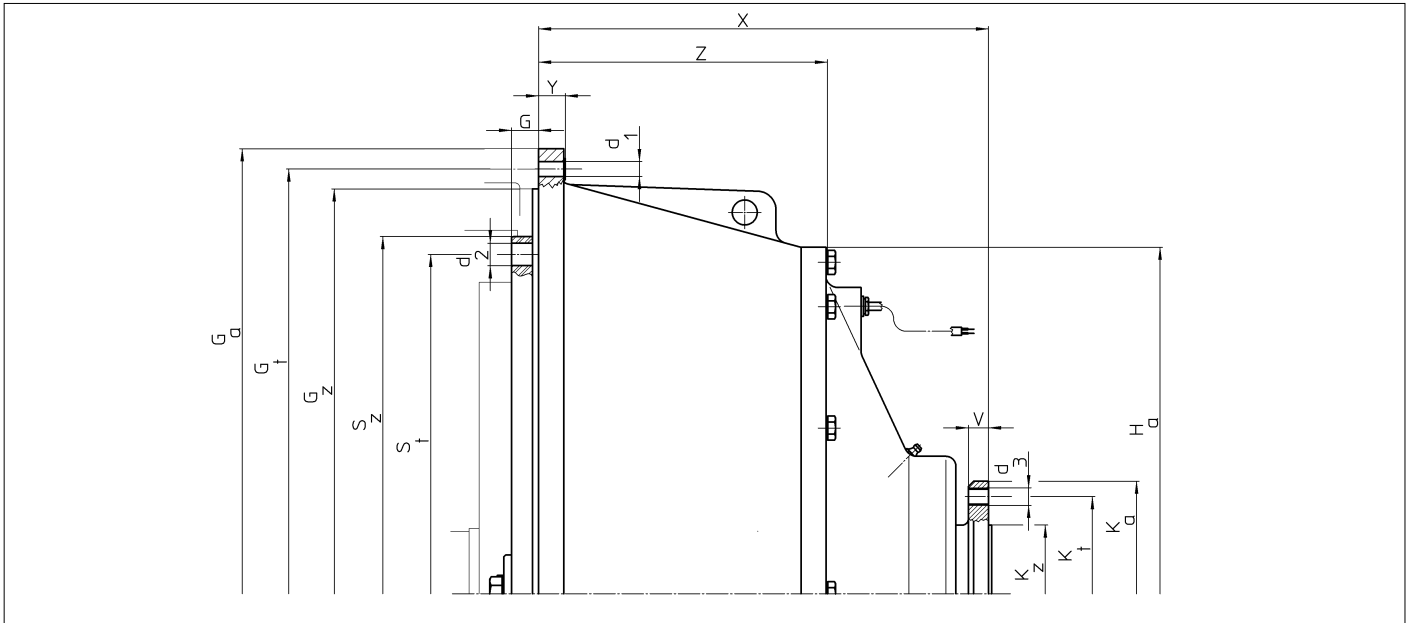

Centa CP size	3			4			5			6		8		9		
Clutch size	50			60			70			80		90		100		
nom. torque T_{KC} [kNm]	0,70			1,40			2,20			2,80		4,20		7		
CF-R coupling size	136			216			216			216		318		520		
nom. torque T_{KN} [kNm]	1,60			3,15			3,15			3,15		6,30		15		
Nom. Voltage [V]	24			24			24			24		24		24		
Nom. Power [W]	136			205			243,5			363,5		307		404		
Flywheel (SAE-J620)	10	11,5	11,5	11,5	11,5	14	11,5	11,5	14	11,5	14	14	18	18	21	
Housing (SAE-J617)	4	3	2	3	2	1	3	2	1	2	1	1	0	0	00	
max. speed [rpm]	4000	4000	4000	3000	3000	3000	3000	3000	3000	3000	3000	2500	2500	2500	2500	
Weight [kg]	46	44	45	110	114	110	118	122	120	126	122	212	215	430	455	
Diameter [mm]	G_a	404	451	489	451	489	552	451	489	552	489	552	552	712	712	883
	G_t	333,4	428,6	466,7	428,6	466,7	530,2	428,6	466,7	530,2	466,7	530,2	530,2	679,5	679,5	850,9
	d_1	11	11	11	11	11	11,5	11	11	11,5	11	11,5	11,5	13	13,5	13,5
	G_z	362	409,6	447,7	409,6	447,7	511,2	409,6	447,7	511,2	447,2	511,2	511,2	647,7	647,7	784,4
	S_z	314,3	352,4	352,4	352,4	352,4	466,7	352,4	352,4	466,7	352,4	466,7	466,7	571,5	571,5	673,1
	S_t	295,3	333,4	333,4	333,4	333,4	438,2	333,4	333,4	438,2	333,4	438,2	438,2	542,9	542,9	641,4
	d_2	11	11	11	11	11	13,5	11	11	13,5	11	13,5	13,5	17	17	17
	H_a	404	404	404	451	489	489	451	489	489	489	489	552	552	635	635
	K_a	100			150			150			150		180		250	
	K_t	84			130			130			130		155,5		218	
	d_3	M8(6x60°)			M12(8x45°)			M12(8x45°)			M12(8x45°)		M14(8x45°)		M18(8x45°)	
K_z	57			90			90			90		110		140		
Length [mm]	U	2			2,5			2,5			2,5		2,5		4	
	V	12			12			12			12		16		16	
	G	53,8	39,6	39,6	39,6	39,6	25,4	39,6	39,6	25,4	39,6	25,4	25,4	15,7	15,7	0
	X	190	190	190	290	290	290	290	290	290	290	290	360	360	535	535
	Y	119	32	32	181	181	32	181	181	32	181	32	231	32,5	32	32
Z	119	119	119	181	181	181	181	181	181	181	181	231	231	365,5	365,5	

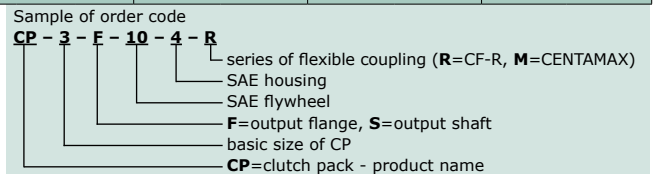

Design

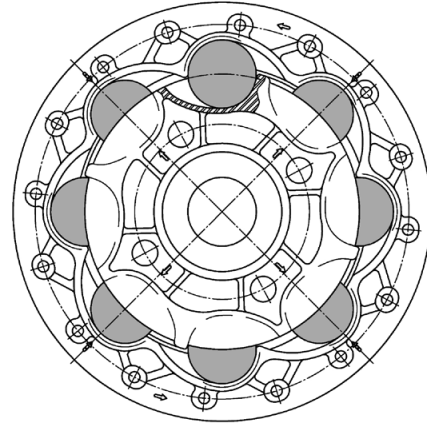
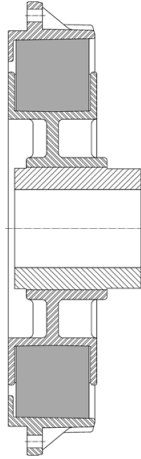

The CENTAFLEX-R is a simple robust ROLLER coupling with a progressive torsional characterisation. Ideal for boat drives, providing a very low stiffness at low torque (& speed) which shifts the torsional resonance below idle speed and prevents gearhammer (gear chatter).

And there are also numerous applications for this kind of coupling in many different industrial drives.

Using the rubber-in-compression principle with rubber rollers between cams, the coupling offers high reliability as it is free from a bonding process common in couplings of equal performance.

The associated cams are profiled using sophisticated computer design (CAD) backed by extensive physical testing.

Important features and advantages of the CENTAFLEX-series R.

- Progressive torsional characteristic with very low stiffness at low torque and increased, but moderate stiffness at high torque

- Fail safe
- Simple, reliable, no bonding, only rubber in compression
- Special developed, temperature resistant elastomer CENTALAN with high damping, suitable for high ambient temperature of more than 100°C (212°F)
- For commercial heavy duty or difficult applications we recommend the special „HD“ rubber rollers, which are also oilresistant.
- Well proven in service and approved by classification societies
- High allowable energy loss by intensive inner and outer ventilation
- Suitable for blind fitting in bell housings
- Economic/easy maintainable design
- Protected by international patents
- Area of application: flange mounted units or well aligned independently mounted units on rigid mounts
- The CF-R is part of the CENTA-Antriebe family of marine drive couplings covering a range between the more than 100 000 times proven CENTAFLEX-DS (Dual Stage) series and the well established, CENTAX series up to 500 kNm.

Technical Data

Centaflex-R size	Rated torque T_K [kNm] for duty:			Max. torque** T_{Kmax} [kNm]	Flywheel size SAE J620	Max. speed [rpm]	This table shows only the basic technical data required for coupling selection based on engine nominal torque and duty only. We can provide much more detailed technical data, which may be required for the conduction of a torsional vibration analysis. Please ask for data sheet D26-003. Torsional Responsibility The responsibility for ensuring torsional compatibility rests with the assembler of the drive train. CENTA cannot accept liability for gearbox noise or for damage of the coupling or other components of the drive caused by torsional vibrations. Torsional vibration analysis can be made by the engine builders, survey societies, consultants etc. or by CENTA. Dimensional Responsibility The dimensions on the flywheel side of the couplings are based on standards SAE J620 and DIN 6281, and special flanges. The responsibility for ensuring dimensional compatibility rests with the assembler of the drive train. CENTA cannot accept liability for interference between the coupling and the flywheel or the gearbox or for damage caused by such interference.
	pleasure*	intermediate	continuous				
94	0,25	0,20	0,17	0,75	6,5 - 165 and special	5000	
114	0,70	0,56	0,49	2,10	11,5 - 290	4000	
134	1,00	0,80	0,70	3,00	11,5 - 290	4000	
136	1,60	1,25	1,11	4,80	11,5 - 290	4000	
216	3,15	2,50	2,20	9,40	11,5 - 290 14 - 355	3500 3000	
268	4,25	3,40	3,00	12,50	14 - 355	3000	
318	6,30	5,00	4,40	19,00	14 - 355 18 - 460	3000 2600	
420	10,00	8,00	7,00	30,00	18 - 460 21 - 530	2600 2300	
520	15,00	12,00	10,50	45,00	18 - 460 21 - 530	2600 2300	
	*The rated torque for pleasure duty is the nominal torque T_{KN} of the coupling.			**Torque for transient conditions	Other flywheel sizes are available	For higher speeds please consult us	

We reserve the right to amend any dimension or detail specified or illustrated in this publication without notice and without incurring any obligation to provide such modification to such couplings previously delivered.

Please ask for an application drawing and current data before making detailed coupling selection.

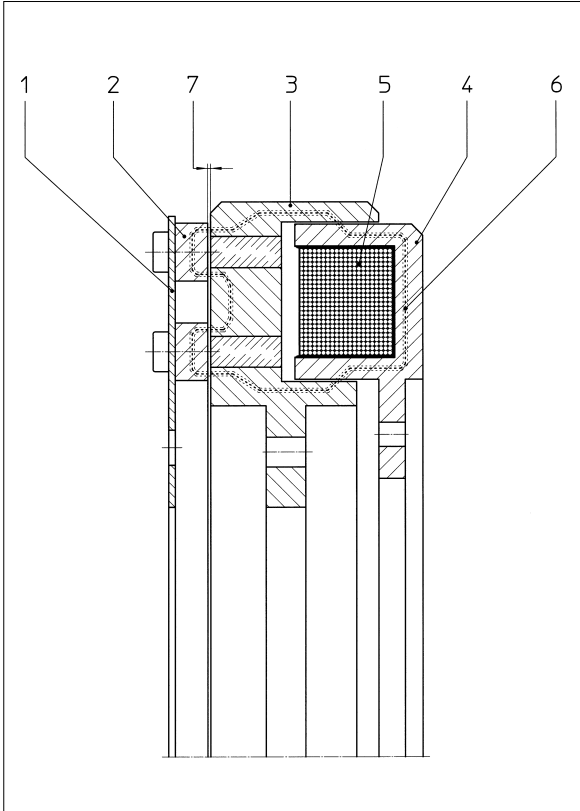

Principle of pole-face friction clutch

The electromagnetically operated pole-face friction clutch without slipping contains 4 pole faces from material with low residual magnetism. The friction parts - armature disc/rotor - are subjected to a special surface treatment thus increasing their wear resistance. The torque ratings assume "dry operation" and apply to the run-in condition. With "wet operation" approx. 1/4 of the "dry operation" ratings are reached. The low-residual material assures shortest possible switching times if the d.c. circuit is switched. We recommend using overvoltage protection for the coil. When the coil is energised a magnetic force exists between the armature disc and the rotor, the flexible spring diaphragm deflects which allows the armature disc to be attracted to the rotor.

The resulting torque transmission is backlash-free. With magnetic coil de-energised, the magnetic field collapses, the restoring force of the diaphragm returns the armature disc back to its initial position creating the original airgap that existed between the armature disc and the rotor.

- 1 Diaphragm - axial spring connects coupling with clutch**
- 2 Armature disc - driving part**
- 3 Rotor - driven part**
- 4 Coil body - non rotating**
- 5 Coil**
- 6 Magnetic flux**
- 7 Airgap, when not engaged**

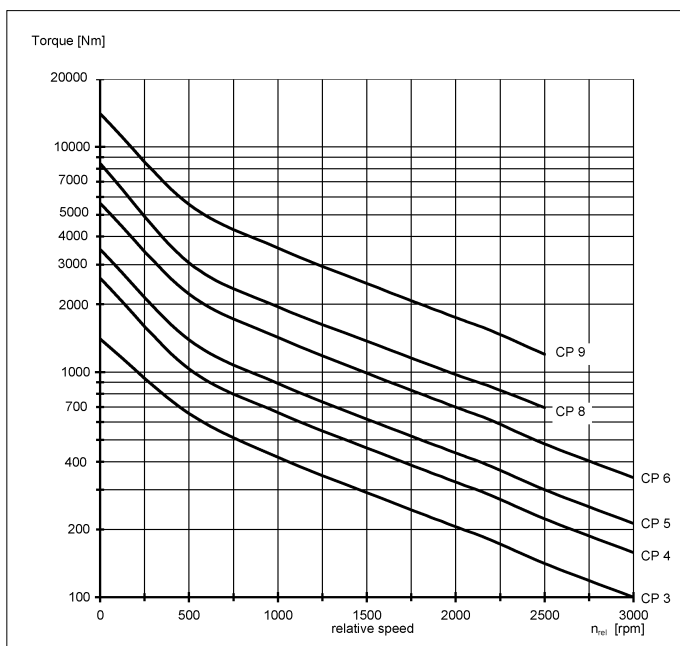

This diagram shows the transmittable torque T (Nm), depending upon the relative speed (slip) n_{rel} (rpm) between driving and driven member. The absorbed torque during engaging at a given relative speed must always be lower than this transmittable torque.

Assembling of CENTA-CP

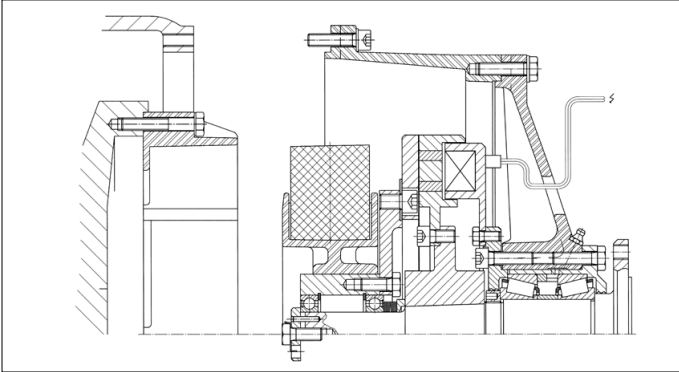

Further CENTA products

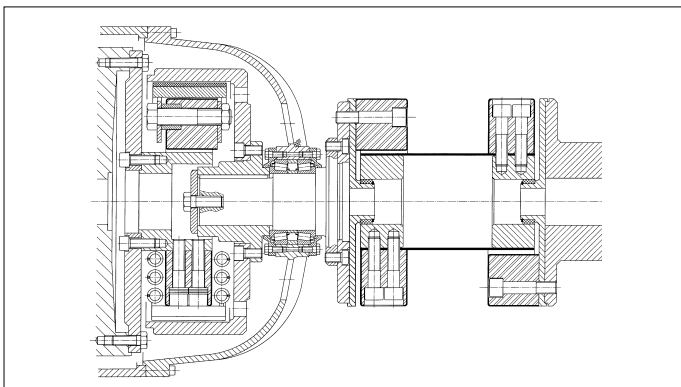
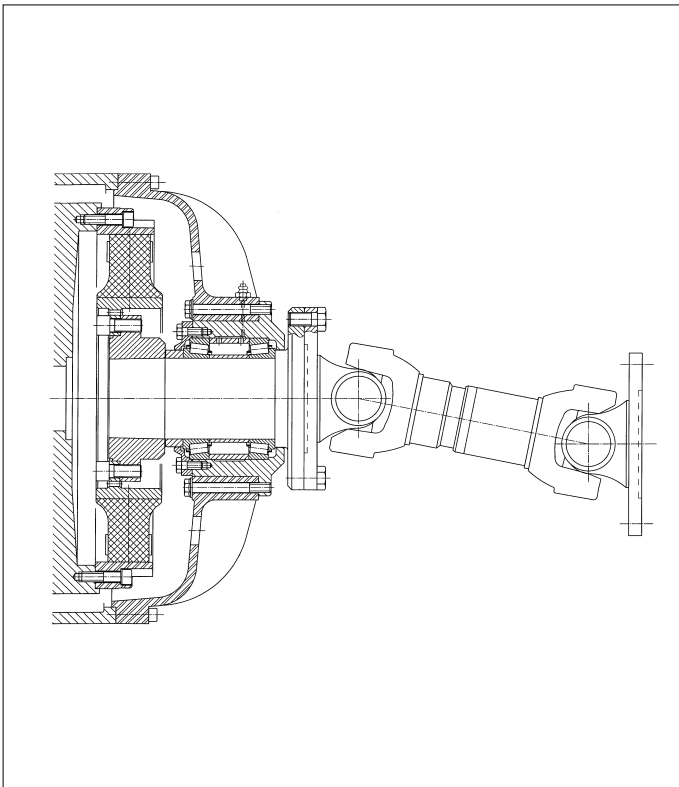

The flywheel flange of the CENTAFLEX-R must be bolted to the flywheel with the correct tightening torque.

All other components are bolted to the flywheel housing as a complete, pre-assembled unit. Please ensure, that the flywheel, flywheel housing and relative position of flywheel mounting face to the flywheel housing is according SAE standard. It is necessary that the engine crankshaft endplay be measured before the driven equipment is installed and rechecked after the driven equipment is installed. The endplay measurements before and after CENTA-CP installation should be the same. If not the same, the reason for this problem must be located and corrected before the engine is started. Engine crankshaft endplay measurement is considered mandatory.

CENTA-FH Flanged Bearing Housing

Every cardan shaft creates axial and radial reaction forces. The amount depends among other reasons on the transmitted torque and the operating angle.

Under considerable operating angle these forces can become dangerous for the crankshaft of the diesel engines.

The CENTA-FH bearing housing has the following advantages:

- Protects the crankshaft from the reaction forces coming from the cardan shaft.
- Ideal torsional vibration tuning due to combination with different types of highly flexible couplings.
- High capacity bearings with long term lubrication to achieve extended lifetime, little maintenance.
- Compact design, light weight due to bearing housing being manufactured from hardened aluminium.
- Extensive internal ventilation to reduce the ambient temperature around the elastic coupling.

Therefore on applications where cardan shaft angles are greater than 3 to 4 degrees most diesel engine manufacturers recommend the use of a flange mounted bearing housing.

This flanged bearing housing transmits the unwanted reaction forces to the flywheel housing, isolating the crankshaft.

The bearing housing is fitted on the flywheel side with either a highly flexible CENTAMAX or a highly flexible CENTAFLEX-R coupling to dampen the torsional vibrations.

CENTASTART

This is another unique CENTA product: A centrifugal clutch - called CENTASTART - with integrated torsional CENTAFLEX- coupling, arranged in a CENTA FH flange housing. Ideally suited for ships using diesel engine and water-jet drives. The centrifugal clutch is disengaged at idling speed but engages automatically when engine speed is increased. Numerous such drives are working satisfactorily in ship propulsion and many other kinds of drives. On the output flange either a normal U/j, or a flexible CENTAFLEX floating shaft can be arranged as shown here. Please ask CENTA for detailed information.

CENTA - the complete range of advanced flexible couplings and shafts for all kinds of boat drives.

CENTA Couplings for flange mounted gears



CENTAMAX-S
linear disc type coupling
T = 0,25 - 40 kNm

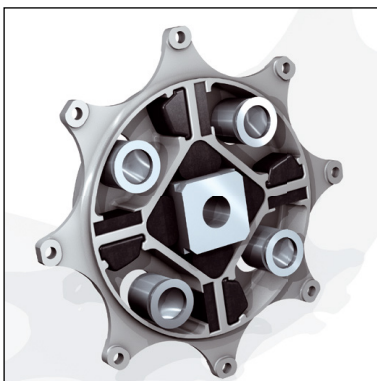

CENTAFLEX-DS
progressive dual stage coupling
T = 0,25 - 2 kNm

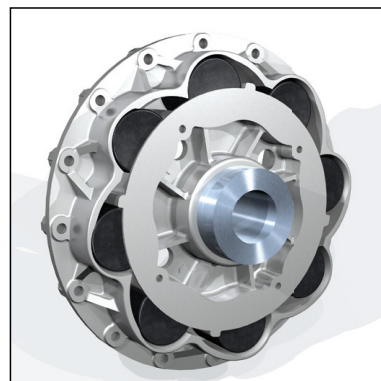

CENTAFLEX-R
progressive roller coupling
T = 0,25 - 15 kNm

Free standing gears - close coupled



CENTAMAX-B
for slight misalignment
T = 0,25 - 20 kNm

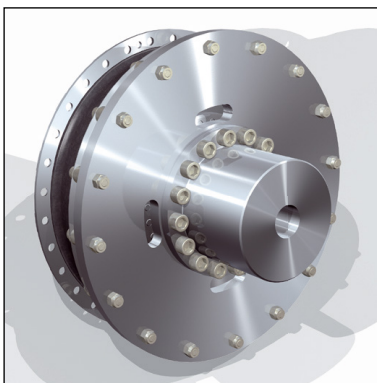

CENTAX-N
for reasonable misalignment
T = 1,1 - 25 kNm

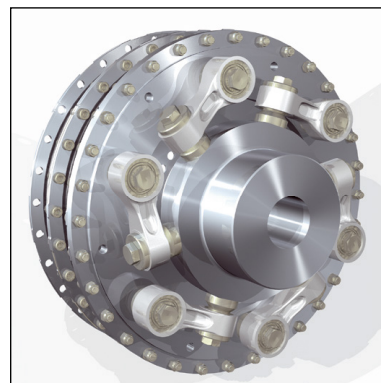

CENTAX-L
for substantial misalignment
T = 2 - 90 kNm

CENTA Couplings for remote mounted gears, V-drives, stern-drives and water jets

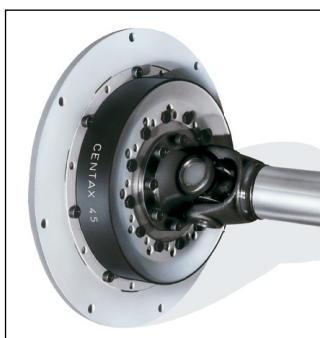

CENTAX-V
intermediate coupling for u/j
T = 0,2 - 50 kNm

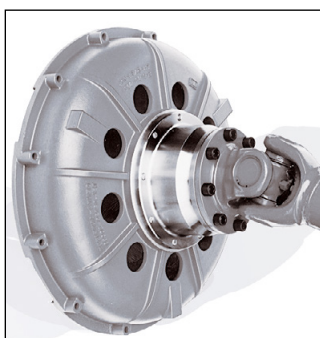

CENTA-FH flange housing
with flexible coupling for u/j
T = 1 - 20 kNm

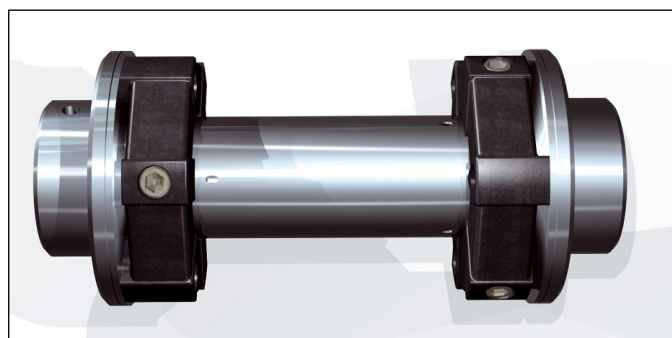

CENTAFLEX-A-G/A-GZ/A-GB
torsional soft flexible shaft for angle up to 2° per element
T = 0,1 - 14 kNm

CENTA also delivers all kinds of flexible couplings and lightweight steel or carbonfibre shafts - with or without propeller thrust - to be installed between gear and propeller or waterjet

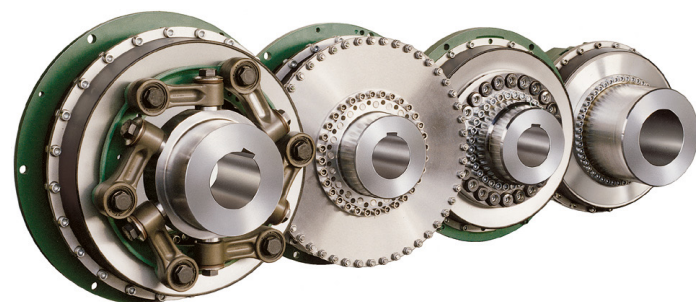

CENTA Couplings for large free standing gears

CENTAX - L - G - B - DP
For larger boats and ships CENTA has the complete range of advanced flexible couplings and shafts up to 650 kNm torque.

CENTA Power Transmission is now part of Rexnord. As a global leader in premium couplings, Rexnord provides the same high quality customer solutions and service you've come to expect from CENTA since 1970.



WWW.CENTA.INFO/CONTACT

WWW.REXNORD.COM

**CENTA
HEAD OFFICE**

Bergische Strasse 7
42781 Haan
Germany

+49-2129-912-0 Phone
+49-2129-2790 Fax

info@centa.de
www.centa.info

**REXNORD POWER TRANSMISSION
HEAD OFFICE**

4701 W Greenfield Ave
Milwaukee, WI 53214
USA

+1-414-643-3000 Phone