

Why Choose Rexnord™ Addax™ Disc Couplings?

EXTENDS SYSTEM LIFE

Lightweight advanced composite materials used in Addax couplings increase the critical speed, reduce vibration and extend bearing life. When compared to alternative metal couplings, the Addax coupling reduces overhung bearing loads by up to 80%.

EASY TO INSTALL

The advanced composite, full-floating center section weighs less than 25% of a comparable steel spacer. Most Addax coupling assemblies weigh less than 100 pounds, oftentimes eliminating the need for cranes and special lifting equipment and assisting maintenance personnel in handling and installation.

DESIGNED TO YOUR SPECIFICATION

Addax couplings are designed specifically for the application and are made to order per the customer's specific needs.

ELIMINATES INTERMEDIATE BEARINGS

The rigid center member and lightweight design of the Addax coupling span the distance from motor to gearbox, without intermediate support bearings.

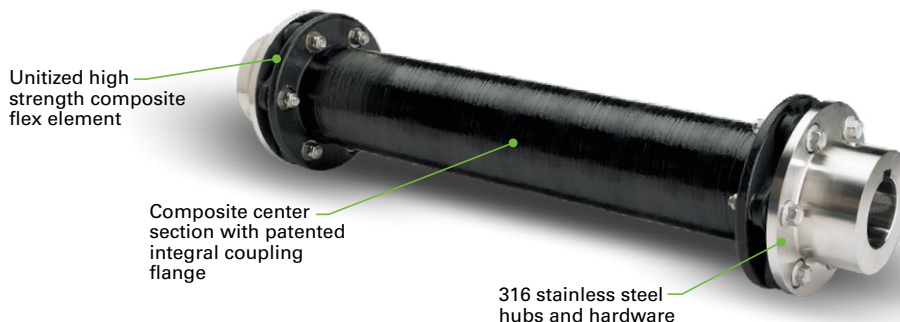

Unitized high strength composite flex element

Composite center section with patented integral coupling flange

316 stainless steel hubs and hardware



Industries Served:

- Cooling Towers
- Power Generation

Addax Cooling Tower Coupling Features:

- Corrosion-resistant center member, flex element, hub and hardware lower the cost of ownership and extend service life
- Patented unitized flex elements provide 1° of misalignment per element and eliminate fretting
- Ships in less than 24 hours if required
- 13 sizes
- Custom spacer lengths, up to 275 inches (6,985 mm)
- Up to 5.06 inches (130 mm) bore capacity
- Up to 36,200 in-lb (4,090 Nm) torque capacity
- Up to 500 hp

Regal Rexnord

Contact us: 1-800-816-5608

regalrexnord.com

The proper selection and application of products and components, including assuring that the product is safe for its intended use, are the responsibility of the customer. To view our Application Considerations, please visit <https://www.regalrexnord.com/Application-Considerations>.

To view our Standard Terms and Conditions of Sale, please visit <https://www.regalrexnord.com/Terms-and-Conditions-of-Sale>.